

Cycling Aspects of Austroads Guides



Austroads



Cycling Aspects of Austroads Guides

First edition prepared by: Gary Veith and Peter Eady

Second edition prepared by: Michael Levasseur

First edition project manager: Duncan Elliot

Second edition project manager: Elaena Gardner

First edition published March 2011

Second edition published April 2014

Pages 166

This is the second edition of *Cycling Aspects of Austroads Guides*. This edition has been revised to ensure its currency and to clarify and highlight links to other Austroads Guides. Key updates include:

- improving cross-references to other Austroads guidance, including summary cross-reference tables at the beginning of each section
- providing broader consideration of other Austroads Guides applicable to cycling
- updating the report to reflect new editions of the *Guide to Traffic Management* (Parts 3, 6 and 9) and *Guide to Road Safety* (Part 1)
- enhancing or clarifying guidance for topics such as path crossings of roads, access considerations at freeway interchanges, construction and maintenance considerations and pavements for cycling.

Abstract

Cycling Aspects of Austroads Guides contains information that relates to the planning, design and traffic management of cycling facilities and is sourced from Austroads Guides, primarily the *Guide to Road Design*, the *Guide to Traffic Management* and the *Guide to Road Safety*.

The document is intended as a guide for engineers, planners and designers involved in the planning, design, construction and management of cycling facilities. Throughout the document practitioners are referred to relevant Austroads Guides for additional information.

The report provides:

- an overview of planning and traffic management considerations and cross-references to other Austroads Guides and texts for further detailed information
- a summary of design guidance and criteria relating to on-road and off-road bicycle facilities together with a high level of cross-referencing to the relevant Austroads Guides for further information
- information and cross-references on the provision for cyclists at structures, traffic control devices, construction and maintenance considerations and end of trip facilities.

ISBN 978-1-925037-59-3

Austroads Project No. NT1792

Austroads Publication No. AP-G88-14

Publisher

Austroads Ltd.
Level 9, 287 Elizabeth Street
Sydney NSW 2000 Australia
Phone: +61 2 9264 7088
austroads@austroads.com.au
www.austroads.com.au



About Austroads

Austroads' purpose is to:

- promote improved Australian and New Zealand transport outcomes
- provide expert technical input to national policy development on road and road transport issues
- promote improved practice and capability by road agencies.
- promote consistency in road and road agency operations.

Austroads membership comprises:

- Roads and Maritime Services New South Wales
- Roads Corporation Victoria
- Department of Transport and Main Roads Queensland
- Main Roads Western Australia
- Department of Planning, Transport and Infrastructure South Australia
- Department of Infrastructure, Energy and Resources Tasmania
- Department of Transport Northern Territory
- Department of Territory and Municipal Services Australian Capital Territory
- Commonwealth Department of Infrastructure and Regional Development
- Australian Local Government Association
- New Zealand Transport Agency.

The success of Austroads is derived from the collaboration of member organisations and others in the road industry. It aims to be the Australasian leader in providing high quality information, advice and fostering research in the road transport sector.

© Austroads Ltd 2014

This work is copyright. Apart from any use as permitted under the *Copyright Act 1968*, no part may be reproduced by any process without the prior written permission of Austroads.

This report has been prepared for Austroads as part of its work to promote improved Australian and New Zealand transport outcomes by providing expert technical input on road and road transport issues.

Individual road agencies will determine their response to this report following consideration of their legislative or administrative arrangements, available funding, as well as local circumstances and priorities.

Austroads believes this publication to be correct at the time of printing and does not accept responsibility for any consequences arising from the use of information herein. Readers should rely on their own skill and judgement to apply information to particular issues.

Summary

This publication contains key information that relates to the planning, design and traffic management of cycling facilities and is sourced from Austroads Guides, primarily the *Guide to Road Design*, the *Guide to Traffic Management* and the *Guide to Road Safety*.

Cycling Aspects of Austroads Guides has been produced to ensure that key information is readily available for practitioners who have a specific interest in cycling issues and facilities. However, users of the report should be aware that:

- The design guidance is summarised for the convenience of practitioners and reference may have to be made to the relevant Austroads Guide for important details relating to particular topics or situations. Consequently this report provides a high level of cross-referencing to Austroads Guides.
- It is highly recommended that practitioners who are less experienced in the planning and design of bicycle facilities refer to the original Austroads Guides.

While the report provides an overview of planning and traffic management considerations, practitioners will need to refer to other Guides and texts for detailed information on these subject areas, some of which are referenced in the Austroads Guides.

Contents

1.	Introduction.....	1
1.1	General.....	1
1.2	How to use this Document	1
1.3	Role of Cycling in Transport	3
1.4	Safe System Approach.....	4
2.	Planning and Traffic Management for Cycling.....	5
2.1	General.....	5
2.2	Bicycle Strategies and Strategic Bicycle Plans	5
2.2.1	National Cycling Strategy	5
2.2.2	State or Territory Bicycle Strategy.....	7
2.2.3	Local Strategic Bicycle Plan	8
2.3	Integrated and Multi-modal Planning.....	9
2.4	Bicycle Network Management.....	9
2.4.1	Introduction	9
2.4.2	Purpose of a Bicycle Network.....	9
2.4.3	Functions of a Bicycle Network	10
2.4.4	Objectives of a Bicycle Network	10
2.4.5	Network and Route Mapping	11
2.4.6	Categories of Cyclists and their Network Requirements	11
2.5	Bicycle Programs.....	12
2.5.1	Behavioural Aspects Programs	12
2.6	Traffic Studies and Bicycle Surveys	13
2.7	Type of Bicycle Facility Required	14
2.8	Combining Bicycle Travel with Public Transport.....	15
2.9	Local Area Traffic Management	16
2.10	Traffic Management in Activity Centres.....	18
2.10.1	Planning Context for Cycling in Activity Centres	18
2.10.2	Bicycles in Activity Centres.....	19
2.10.3	Cycling Implications for Traffic Management Practice in Activity Centres	19
2.11	Traffic Impacts of Developments.....	21
3.	Bicycle Rider Requirements.....	22
3.1	General.....	22
3.2	Space to Ride.....	23
3.3	Smooth Surface.....	24
3.4	Speed Maintenance.....	24
3.5	Sight Lines.....	24
3.6	Connectivity.....	24
3.7	Information.....	25
4.	Bicycle Facilities On-Road (Mid-Block)	26
4.1	General.....	26
4.1.1	Types of On-road Bicycle Facilities	26
4.2	Key Design Criteria and Considerations	28
4.2.1	Road Geometry	28
4.2.2	Gradients	28
4.2.3	Cross-section and Clearances	28

4.3	Provision for Cyclists on Roads.....	29
4.3.1	General.....	29
4.3.2	Exclusive Bicycle Lanes.....	29
4.3.3	Wide Kerbside Lanes.....	32
4.3.4	Sealed Shoulders.....	33
4.3.5	Bus/Bicycle Lanes.....	33
4.3.6	Advisory Treatments.....	34
4.4	Types of Bicycle Lane Treatments.....	34
4.4.1	Bicycle/Car Parking Lanes.....	34
4.4.2	Contra-flow Bicycle Lanes.....	37
4.4.3	Separated Bicycle Lanes.....	38
4.4.4	'Peak Period' Bicycle Lanes.....	40
4.4.5	Protected Two-way Lanes.....	41
4.5	Finding Space for Bicycle Lane Treatments.....	42
4.6	Supplementary Road Treatments.....	42
4.6.1	Curves and Turns.....	42
4.6.2	Lane Channelisation.....	43
4.7	Ramps.....	43
4.8	Provision for Cycling on Freeways.....	45
4.8.1	General.....	45
4.9	Local Area Traffic Management Schemes.....	46
5.	Provision for Cycling at Road Intersections and Interchanges.....	50
5.1	Introduction.....	50
5.2	Issues at Intersections for Cyclists.....	51
5.2.1	General.....	51
5.3	Signalised Road Intersections.....	52
5.3.1	General.....	52
5.3.2	Traffic Management Guidelines.....	53
5.3.3	The Six Elements.....	54
5.3.4	Bicycle Lanes.....	56
5.3.5	Head-start and Expanded Storage Areas.....	58
5.3.6	Hook Turn Storage Boxes and Hook Turn Restrictions.....	60
5.3.7	Left-turn Treatments.....	61
5.3.8	Bypass of T-intersection.....	63
5.3.9	Crossings at Signalised Intersections.....	63
5.3.10	Signalised Mid-block Crossings.....	66
5.4	Unsignalised Road Intersections.....	67
5.4.1	General.....	67
5.4.2	Basic and Channelised Intersections.....	67
5.4.3	Channelised Left-turn Treatment.....	69
5.4.4	Refuge within an Unsignalised Intersection.....	71
5.5	Roundabouts.....	72
5.5.1	Introduction.....	72
5.5.2	Local Roads – No Bicycle Facility.....	75
5.5.3	Bicycle Lanes at Single-lane Roundabouts.....	76
5.5.4	Multi-lane Roundabouts on Arterial Roads.....	78
5.5.5	Bicycle Paths and Shared Paths at Roundabouts.....	81
5.6	Road Interchanges.....	82
5.6.1	General.....	82
5.6.2	At-grade Treatment at Interchanges.....	83
5.6.3	Grade Separation of Ramps for Cyclists.....	85
5.6.4	Alternative Routes.....	85

6.	Provision for Cycling at Rail Crossings.....	86
6.1	General.....	86
6.2	Types of Rail Crossings.....	86
6.3	Key Requirements and Considerations.....	86
6.3.1	On-road Railway Level Crossings.....	87
6.4	Path Crossings.....	87
6.4.1	Grade Separation for Paths.....	88
7.	Paths for Cycling.....	89
7.1	General.....	89
7.2	Types of Path.....	89
7.3	Choice of Appropriate Type of Path.....	91
7.4	Location of Paths for Cycling.....	91
7.5	Path Design Criteria for Bicycles.....	92
7.5.1	General.....	92
7.5.2	Bicycle Operating Speed.....	92
7.5.3	Horizontal Alignment.....	93
7.5.4	Width.....	94
7.5.5	Vertical Alignment.....	95
7.5.6	Crossfall and Drainage.....	96
7.5.7	Clearances, Batters and Fences.....	97
7.5.8	Sight Distance.....	99
7.6	Path Crossings of Roads.....	101
7.6.1	General.....	101
7.6.2	Grade Separated Bicycle Path Crossing.....	102
7.6.3	Signalised Bicycle Path Crossing.....	103
7.6.4	Unsignalised Bicycle Path Crossing.....	103
7.6.5	Path Approach Design Criteria.....	107
7.6.6	Types of Crossings of Side Roads.....	108
7.7	Intersections of Paths with Paths.....	112
7.7.1	Considerations.....	112
7.7.2	Design of Intersections of Paths with Paths.....	112
7.8	Path Terminal Treatments.....	115
7.9	Fences and Road Safety Barriers.....	117
7.9.1	Fences.....	117
7.9.2	Road Safety Barriers.....	117
7.10	Road and Path Lighting.....	118
8.	Cycling Provision at Structures.....	119
8.1	General.....	119
8.2	Bridges and Underpasses.....	119
8.3	Road Tunnels.....	120
9.	Traffic Control and Communication Devices.....	121
9.1	General.....	121
9.2	Signs.....	121
9.2.1	Signing of Bicycle Routes.....	122
9.3	Pavement Markings.....	122
9.3.1	Roads.....	122
9.3.2	Paths.....	122
9.4	Pavement Surface Colour.....	124
9.5	Cyclists at Traffic Signals.....	124
9.5.1	Traffic Signal Displays for Cyclists.....	124
9.5.2	Bicycle Detection.....	125
9.5.3	Treatments for Cyclists at Traffic Signals.....	125

10. Construction and Maintenance Considerations at Cycling Facilities.....	127
10.1 General.....	127
10.2 Pavements for Cycling	127
10.3 Maintaining Cycling Facilities	128
10.3.1 Bicycle Safety Audits	128
10.3.2 Further Guidance.....	128
11. Bicycle Parking and End-of-trip Facilities	129
11.1 General.....	129
11.2 Bicycle Parking.....	130
11.2.1 General.....	130
11.2.2 General Requirements of Devices.....	130
11.2.3 Location of Bicycle Parking Facilities	131
11.3 On-street Bicycle Parking.....	131
11.4 Types of Parking Devices.....	132
11.5 Signs and Markings Showing Location and Purpose of Parking Facilities	134
11.6 Showers, Lockers and Security.....	135
References	136
Appendix A Bicycle Network Evaluation Example.....	140
Appendix B Australian Bicycle Council Website	144
Appendix C Bicycle Survey Methods	145
Appendix D Human Powered Vehicles.....	148
Appendix E Construction and Maintenance	149
Appendix F Bicycle Safety Audit Checklist.....	158
Appendix G Example of Bicycle Safety Audit.....	163
Appendix H Bicycle Parking Provision Rates	165

Tables

Table 1.1:	Austroads Guides cross-referenced in document	2
Table 2.1:	Key cross-references related to planning and traffic management for cycling.....	6
Table 2.2:	Bicycle network features.....	9
Table 2.3:	Bicycle network functions	10
Table 2.4:	Categories of cyclists and their characteristics	11
Table 2.5:	Use, advantages and disadvantages of bicycle lanes, advisory treatments and bypasses in LATM schemes	17
Table 2.6:	Example of guiding principles and criteria for bicycle plans.....	18
Table 3.1:	Key cross-references related to bicycle rider requirement	22
Table 4.1:	Key cross-references related to bicycle facilities on road (mid-block).....	27
Table 4.2:	Clearance to cyclist envelope from adjacent truck	28
Table 4.3:	Exclusive bicycle lane dimensions in urban areas	31
Table 4.4:	Wide kerbside lane dimensions.....	32
Table 4.5:	Width of kerbside bus lanes	34
Table 4.6:	Bicycle/car parking lane dimensions (parallel parking).....	35
Table 4.7:	Bicycle/car parking lane dimensions (angle parking).....	36
Table 4.8:	Considerations in the design of kerb separated bicycle lanes.....	39
Table 4.9:	Cyclist use of freeways – factors to consider	45
Table 4.10:	Factors to consider for cycling in regards to LATM schemes.....	46
Table 5.1:	Key cross-references related to provision of cycling at road intersections and interchanges.....	50
Table 5.2:	Issues for cyclists	51
Table 5.3:	Cyclist requirements for arterial road signalised approaches	53
Table 5.4:	Cyclist requirements for local road signalised approaches	53
Table 5.5:	Lane management at signalised intersections for on-road bicycle lanes.....	54
Table 5.6:	Summary of use of the head-start treatments illustrated in Figure 5.5.....	59
Table 6.1:	Key cross-references related to cyclists at rail crossings.....	86
Table 6.2:	Considerations for pedestrians and cyclists at railway crossings	87
Table 7.1:	Key cross-references related to paths for cycling.....	90
Table 7.2:	Cross-references for path key design criteria	92
Table 7.3:	Minimum radii of horizontal curves without superelevation.....	93
Table 7.4:	Minimum radius of horizontal curves that have superelevation.....	93
Table 7.5:	Bicycle path widths.....	94
Table 7.6:	Shared path widths.....	94
Table 7.7:	Separated two-way path widths	95
Table 7.8:	Separated one-way path widths	95
Table 7.9:	Benefits of treatments – grade separated facilities	102
Table 8.1:	Key cross-references related to cyclist provision at structures.....	119
Table 9.1:	Key cross-references related to traffic control and communication devices.....	121
Table 9.2:	Signal timing and phasing treatments for cyclists.....	126
Table 10.1:	Key cross-references related to construction and maintenance	127
Table 11.1:	Key cross-references related to bicycle parking and end-of-trip facilities.....	129
Table 11.2:	Classification of bicycle parking facilities	132

Figures

Figure 2.1:	On-road instruction in safe cycling procedures	12
Figure 2.2:	Separation of cyclists and motor vehicles by speed and volume	15
Figure 2.3:	Bicycle lane example	16
Figure 2.4:	Examples of bicycle bypasses of LATM devices	17
Figure 3.1:	Cyclist envelope	23
Figure 4.1:	An example of an exclusive bicycle lane	30
Figure 4.2:	Wide kerbside lane	32
Figure 4.3:	Typical bicycle/car parking lanes layout (parallel parking)	35
Figure 4.4:	Typical bicycle/car parking lanes layout (angle parking)	36
Figure 4.5:	Contra-flow bicycle lane example	37
Figure 4.6:	Location and typical cross-section of kerb separated bicycle lane	38
Figure 4.7:	Kerb separated bicycle lane	39
Figure 4.8:	Typical cross-section of a separated protected bicycle lane	40
Figure 4.9:	Peak period bicycle lane (i.e. during and outside clearway times)	41
Figure 4.10:	Low and high-speed exit and entry ramps	44
Figure 4.11:	Example of good practice – cycle bypass of a road hump	48
Figure 4.12:	Parked vehicle blocks cycle bypass	48
Figure 4.13:	Cycle bypass at half road closure	49
Figure 5.1:	Provision of a bicycle operating space at intersections – the six elements	54
Figure 5.2:	Design options for signalised intersections (mid-block, transition and approach)	55
Figure 5.3:	Design options for signalised intersections (waiting, through and departure)	56
Figure 5.4:	Bicycle lanes through signalised intersections – car side and kerbside	57
Figure 5.5:	Head-start and expanded storage areas	58
Figure 5.6:	Bicycle hook turn box detail	60
Figure 5.7:	Provision for cyclists at a signalised CHL treatment in a low-speed environment	61
Figure 5.8:	Bicycle lane left-turn bypass at a signalised intersection	62
Figure 5.9:	Cyclist bypass lane at a signalised T-intersection	63
Figure 5.10:	Shared path and two-way bicycle path at a signalised intersection	64
Figure 5.11:	Right turn from an off-road bicycle path to an on-road bicycle lane	65
Figure 5.12:	Signalised crossing with separate pedestrian and cyclist areas	66
Figure 5.13:	Urban basic (BA) intersection turn treatments	67
Figure 5.14:	Urban channelised (CH) intersection turn treatments	68
Figure 5.15:	Provision for cyclists at an unsignalised CHL treatment in a low-speed environment	69
Figure 5.16:	An example of provision for cyclists at rural free-flow left-turn treatments	70
Figure 5.17:	Refuge within an intersection for pedestrians and cyclists in bicycle lanes	71
Figure 5.18:	Roundabout at a T-intersection – path connecting bicycle lanes	73
Figure 5.19:	Bicycle lane continuing past a left-turn slip lane at a roundabout	74
Figure 5.20:	Bicycle route through a single-lane roundabout – no bicycle facility	75
Figure 5.21:	Bicycle lane at a small single-lane roundabout on a local road)	76
Figure 5.22:	Two bicycle routes crossing at a single-lane roundabout with physically separated bicycle lanes	77
Figure 5.23:	Two bicycle routes crossing at a single-lane roundabout with no physical separation of bicycle lanes	78
Figure 5.24:	Bicycle lanes at a two-lane roundabout with physical separation for cyclists	79
Figure 5.25:	Details of an island on a multi-lane roundabout entry to separate cyclists and motorists	80
Figure 5.26:	Details of an island on a multi-lane roundabout exit to separate cyclists and motorists	80
Figure 5.27:	Path at a roundabout where cyclist and pedestrian volumes are low to moderate	81
Figure 5.28:	Crossing detail for a shared path adjacent to a multi-lane roundabout	82
Figure 5.29:	Typical at-grade treatment for cyclists at exit and entry ramps	84
Figure 6.1:	Examples of signs used at pedestrian and cyclist crossings of railways	88
Figure 7.1:	Guide to the choice of path treatment for cyclists	91
Figure 7.2:	Desirable uphill gradients for ease of cycling	96
Figure 7.3:	Requirement for fence barriers at batters and vertical drops	98
Figure 7.4:	Minimum stopping sight distance for cyclists	99

Figure 7.5:	Lateral clearances on horizontal curves	100
Figure 7.6:	Minimum length of crest vertical curves	101
Figure 7.7:	Bicycle path crossing of a two-way two-lane road and separated paths	104
Figure 7.8:	Example of a cyclist and pedestrian refuge at a mid-block location.....	105
Figure 7.9:	Cyclist priority treatment for use at low-volume street crossing	106
Figure 7.10:	Bicycle path crossing bent-out at side road.....	109
Figure 7.11:	Bicycle path crossing (not bent-out at side road)	110
Figure 7.12:	One-way bicycle path crossing (bent-in side road)	111
Figure 7.13:	Intersections of paths with paths	113
Figure 7.14:	Intersection of bicycle path and footpath where cyclists have priority.....	114
Figure 7.15:	Intersection of a separated path and footpath (cyclists give way).....	115
Figure 7.16:	Separate entry and exit terminal.....	116
Figure 7.17:	Example of a bollard treatment.....	116
Figure 7.18:	Staggered fence treatment	117
Figure 9.1:	Example of bicycle lane markings	123
Figure 9.2:	Bicycle signal aspect	124
Figure 11.1:	Bicycle parking in main street shopping precinct (Hamilton, NZ).....	131
Figure 11.2:	Bicycle parking, Reddacliff Place, Brisbane CBD, Qld.....	132
Figure 11.3:	Example of bicycle lockers location at a bus terminal in Canberra	133

1. Introduction

1.1 General

This document is intended as a guide for engineers, planners and designers involved in the planning, design, construction, maintenance and management of cycling facilities. It consolidates and summarises the information in current Austroads Guides, in particular the *Guide to Road Design* and the *Guide to Traffic Management*, so that the information on bicycle facilities is readily available for persons with a particular interest in the topic. Throughout the document practitioners are referred to relevant Austroads Guides for additional information. Although this document focuses on the Guides noted above, it cross-references material in a number of other Austroads Guides.

1.2 How to use this Document

The *Cycling Aspects of Austroads Guides* consolidates information relating to on-road bicycle facilities and provides a summary of key design information for cyclist paths, including intersections of paths with roads.

Table 1.1 provides a summary of the Austroads Guides relevant to the remaining sections in this document. In addition, each of the remaining sections includes a table summarising relevant Austroads Guides and key sections of those Guides.











Practitioners should use this document to support national and state cycling strategies (Section 2.2) so that communities can obtain environmental, health and transport benefits that are derived from increased cycling. Cycling can be encouraged by the provision of bicycle access into and through all new land developments, the provision of treatments that assist bicycle travel and the provision of satisfactory showers and secure parking facilities in the workplace. Some information on end-of-trip facilities is also provided.

Cycling should be considered in all road planning, design, construction and maintenance activities. It should also be understood that cyclists basically need a smooth hazard-free riding environment and, where they share roads, they need sufficient space to operate alongside motor vehicles. As far as practicable, roadsides and roadside objects should also be designed to provide a forgiving environment for errant bicycles (e.g. the surface provided on a shoulder or berm should not trap bicycle tyres).











As bicycle riders include people with a very wide range of skills and ages (from novices to experts), and also people who travel for a variety of reasons, it is essential to cater for them even though this may result in more than one type of bicycle facility along a given route (Section 2.7).

Table 1.1: Austroads Guides cross-referenced in document

Section of <i>Cycling Aspects of Austroads Guides</i>			
Guide	Topics	Guide	Topics
Section 2: Planning and Traffic Management for Cyclists			
	Bicycle planning, bicycle networks , categories of cyclists combining bicycle travel with public transport		Bicycle surveys, analysis and multimodal level of service
	Bicycle planning		Cycling considerations and traffic management practices in or near activity centres
	Integrated and multi-modal planning		Cycling considerations with local area traffic management
	Examples of project evaluation including the evaluation of a bicycle capital works program		Cycling needs in assessing access requirements to and within developments
	Example of a bicycle behavioural aspects program		
Section 3: Bicycle Rider Requirements			
	Basic bicycle rider requirements		Basic bicycle rider requirements
Section 4: Bicycle Facilities On-road (Mid-block)			
	Design considerations and on- road bicycle facilities		Considerations for cyclists in the design of local area traffic management schemes
	Traffic management considerations for on-road bicycle facilities		Road safety barriers at cyclist facilities
	Cyclists on freeways and at freeway interchanges		
Section 5: Cyclists at Road Intersections and Interchanges			
	Factors to consider in managing cycling facilities at intersections		Roundabout design
	Unsignalised and signalised intersection design		Interchange design
Section 6: Cyclists at Rail Crossings			
	Traffic management considerations for cyclists at rail crossings		
Section 7: Cyclist Paths			
	Design of paths for cyclists		Fences and road safety barriers for cycling facilities
	Traffic management considerations at the intersections of paths with paths		Road and path lighting for cycling facilities

Section of <i>Cycling Aspects of Austroads Guides</i>			
Guide	Topics	Guide	Topics
Section 8: Provision for Cyclists at Structures			
	Guidance on the provision of facilities for cyclists at structures		Planning for and accommodating cyclists at road tunnels
	Planning for and accommodating cyclists at bridges		
Section 9: Traffic Control and Communication Devices			
	Signs, pavement markings, pavement surface colours and bicycle traffic signal displays		Traffic signal operation and bicycle detection
Section 10: Construction and Maintenance Considerations for Cyclists			
	Maintenance requirements, pavements and surfacing, provision for cyclists at work sites, quality systems		Design, evaluation, treatment and maintenance of pavements
	Bicycle safety audits		Project delivery in relation to asset function and strategic planning process
	Management of cycling related infrastructure		
Section 11: Bicycle Parking and End-of-trip Facilities			
	Parking requirements for cyclists, showers, lockers and security		

Notes:

	Guide to Traffic Management (GTM)		Guide to Road Design (GRD)		Guide to Road Safety (GRS)
	Guide to Project Evaluation (GPE)		Guide to Asset Management (GAM)		Guide to Bridge Technology (GBT)
	Guide to Pavement Technology (GPT)		Guide to Road Tunnels (GRT)		Guide to Road Transport Planning (GRTP)
	Guide to Project Delivery (GPD)				

1.3 Role of Cycling in Transport

Cycling currently fulfils an important transport role within communities. It is the most sustainable, reliable, effective and efficient form of transport. It allows people to travel large distances at low cost and is very reliable.

Efficient transportation of people and goods in cities is essential if the economic and social needs of society are to be met. Whilst the private motor car is a more prevalent mode (by the community at large) for most trips in cities, it has undesirable aspects in relation to traffic congestion, road safety, noise, and air pollution. Modes of transport which could play a greater role in offsetting these issues include walking, cycling, trains, trams and buses.

Cycling produces minimal greenhouse gases, creates no significant congestion and is well suited to many of the trips currently made in cars, particularly in inner urban areas. Many car trips, including travel to work, are less than 10 kilometres, a distance that can be covered in many inner urban areas as quickly on a bicycle as in a car.

Cycling offers significant environmental and health benefits for communities and must therefore be considered in all planning activities ranging from the development of cities and new towns to relatively small infrastructure developments. The recognition of cyclist needs will ensure that current planning decisions do not limit the ability of responsible authorities to provide satisfactory networks and facilities for bicycle riders in the future.

Surveys conducted in major Australian and New Zealand cities have shown that cycling is popular and is increasing as a means of transport and for recreation. The *Australian Cycling Participation 2011* survey (Austroads 2011a) provided an overview of cycling participation in Australia. Follow up surveys have been proposed for 2013 and 2015.

1.4 Safe System Approach

Safe System principles have been acknowledged in successive national road safety strategies and action plans since 2003 as the guiding principles for road safety programs in Australia. The commitment is continued in the current strategy, *National Road Safety Strategy 2011–2020* (Australian Transport Council 2011). Safe System principles are also central to *Safer Journeys, New Zealand's Road Safety Strategy 2010–2020* (Ministry of Transport 2010).

The Safe System framework requires that:

- The road transport system is designed, built and maintained so that the forces road users are subjected to in collisions will not result in death or serious injury.
- Roads and roadsides should be improved to reduce the risk of crashes and the severity of impacts when crashes do occur; vulnerable road users must be considered in this process.
- Inclusion of effective active and passive safety systems in vehicles should be encouraged to reduce the number of crashes and reduce the impact forces on occupants and road users outside the vehicle.
- Speeds should be managed, taking account of the risks on different parts of the road transport system.

Based on this approach, 'the human body's tolerance to crash forces will need to be the key design factor for the system. Crash forces would be managed so they do not exceed these limits' (Ministry of Transport 2010). For instance, as vehicle speeds increase above 30 km/h the likelihood of a pedestrian or cyclist being killed or seriously injured increases considerably (Austroads 2009l, Global Road Safety Partnership 2008). A Safe System aims to protect vulnerable road users 'by providing safer infrastructure, by encouraging the uptake of vehicles that inflict less harm on vulnerable users in a crash, and by managing speeds to reduce serious injury risk' (Ministry of Transport 2010).

Practitioners should be aware of and through the design process actively support the philosophy and road safety objectives covered in the *Guide to Road Safety*. The philosophy and objectives are as relevant to cycling facilities as they are to roads in general.

For additional guidance on the Safe System approach, refer to the *Guide to Road Safety Part 1* (Austroads 2013a) and the *Guide to Traffic Management Part 13* (Austroads 2009k).

2. Planning and Traffic Management for Cycling

2.1 General

Bicycle planning, the development of bicycle networks and managing the needs of cyclists in relation to other modes of traffic are discussed in this section. This material is sourced primarily from the Guide to Traffic Management. Table 2.1 summarises key cross-references in Section 2.

2.2 Bicycle Strategies and Strategic Bicycle Plans

The main goal of bicycle planning is to encourage cycling as a desirable alternative to motor vehicle travel and to provide community and government programs which will provide for safer and more convenient travel by bicycle.

The development of strategies is important because they provide a framework and direction for the development and coordination of programs throughout government and should constitute a commitment to various initiatives and actions. They also provide for the integration of cyclist needs into all planning and design activities including commercial and industrial building designs, land development plans, subdivision plans, road designs and road maintenance programs.

Therefore bicycle planning needs to include:

- development of broad bicycle policies and bicycle strategies at both national and state levels which includes all aspects of cycling, involves all relevant departments and municipalities, and assigns responsibilities
- development of local strategic bicycle plans on a municipal basis which set local strategies and defines local bicycle networks in relation to the principal or regional bicycle network (if one exists). These plans should also identify local needs for programs, and for road and path improvements.

These strategies and plans provide a statement of actions which are based, although not necessarily rigidly, on encouragement, education, engineering and enforcement.













2.2.1 National Cycling Strategy

The Australian National Cycling Strategy 2011–2016 (Austroads 2010d) is a strategic document with a vision to double the number of people cycling over the life of the strategy so that individuals and communities can enjoy the benefits of cycling (e.g. those relating to urban space and traffic congestion, the environment and health). The strategy includes six priorities and associated objectives that are needed to drive progress at the national level, namely:





1. Cycling promotion – Promote cycling as a viable and safe mode of transport and an enjoyable recreational activity.
2. Infrastructure and facilities – Create a comprehensive and attractive network of routes to cycle and end-of-trip facilities.
3. Integrated planning – Consider and address cycling in all relevant transport and land-use planning activities.
4. Safety – Enable safer cycling.
5. Monitoring and evaluation – Improve monitoring and evaluation of cycling programs and develop a national decision-making process for investment in cycling.

Guidance and best practice – Develop nationally consistent guidance for stakeholders to use and share best practice across jurisdictions.

Table 2.1: Key cross-references related to planning and traffic management for cycling

Section of <i>Cycling Aspects of Austroads Guides</i>					
Guide	Section	Reference source	Guide	Section	Reference source
Section 2.2: Bicycle Strategies and Strategic Bicycle Plans					
	Section 4.6	Austroads (2014a)		Section 2.1	Austroads (2009f)
Section 2.3: Integrated and Multi-modal Planning					
	General	Austroads (2009i)			
Section 2.4: Bicycle Network Management					
	Section 4.6	Austroads (2014a)		Section 6.2.4	Austroads (2009j)
Section 2.5: Bicycle Programs					
	Section 4.6	Austroads (2014a)		Section 3.10	Austroads (2006a)
Section 2.6: Traffic Studies and Bicycle Surveys (also Appendix C)					
	Section 2.5.5 Appendix E.2	Austroads (2013b)			
Section 2.7: Type of Bicycle Facility Required					
	Section 4.6.5	Austroads (2014a)			
Section 2.8: Combining Bicycle Travel with Public Transport					
	Section 4.6.8	Austroads (2014a)			
Section 2.9: Local Area Traffic Management (also Section 4.9)					
	Sections 7.5.11 and 8.12.1	Austroads (2008a)			
Section 2.10: Traffic Management in Activity Centres					
	Sections 2.3.2, 3.8.3 and 3.8.4	Austroads (2009a)			
Section 2.11: Traffic Impacts of Developments					
	Sections 3.2.7 and 4.4.10	Austroads (2009c)			

Notes:

	Guide to Traffic Management (GTM)		Guide to Road Design (GRD)		Guide to Road Safety (GRS)
	Guide to Project Evaluation (GPE)		Guide to Road Transport Planning (GRTP)		

The national strategy in New Zealand is *Getting there – on foot, by cycle: A strategy to advance walking and cycling in New Zealand transport* (Ministry of Transport 2005). This strategy aims to ensure that supportive walking and cycling environments are provided in New Zealand communities, that safety is improved for pedestrians and cyclists, and that people walk and cycle more as part of their day-to-day transport mix. A related document is *Getting there – on foot, by cycle: Strategic implementation plan 2006–2009* (Ministry of Transport 2006). It provides 10 action items across the following four focus areas:

1. strengthening foundations for effective action
2. providing supportive environments and systems
3. influencing individual travel choices
4. improving safety and security.

The development of walking and cycling is integral to achieving the five transport targets within the *New Zealand Transport Strategy* (Ministry of Transport 2008) which comprise:

- ensuring environmental sustainability
- assisting economic development
- assisting safety and personal security
- improving access and mobility
- protecting and promoting public health.

2.2.2 State or Territory Bicycle Strategy

State or territory strategies on cycling are necessary to set a direction and provide a framework within which various responsible agencies can plan and work. They also specify important strategic action areas and items and nominate responsible 'lead agencies'.

It is desirable that the specific aims of a state or territory strategy:

- establish a key group to administer and coordinate the implementation of the strategy
- ensure that planning for cycling is integrated within overall transport and land use planning, urban development, building rules, traffic management and community planning
- give priority to those areas where the existing or potential demand for cycling is highest
- ensure that cyclists have suitable and legitimate access to roads and paths, where appropriate
- ensure the development of programs promoting cycling as a legitimate form of transport
- ensure the development of behavioural and safety awareness programs aimed at improving cyclist safety in general
- ensure support for key promotional activities e.g. Bike Week, Ride to Work
- ensure an appropriate legislative framework for cycling having regard to safety, good traffic engineering practice and credibility of the law
- encourage cycling for the environmental, recreational and health benefits to cyclists and the wider community
- reduce the frequency of bicycle crashes and the severity of injuries resulting from crashes
- coordinate the provision of cycling facilities and programs across relevant agencies and organisations
- develop, implement and maintain a state-wide bicycle route network incorporating metropolitan routes, interregional routes and routes within regional centres and municipalities
- ensure cycling facilities and programs are readily accessible
- ensure cycling facilities serve the needs of the relevant categories of cyclists

- provide guidance to encourage a high level of compliance by cyclists with traffic laws, and by other road and path users in relation to cyclists, covering both educational and enforcement needs
- encourage the establishment of a strong and pro-active cycling industry, including manufacturers, traders and the tourism industry operators
- ensure the systematic measuring, auditing or evaluation, of programs and facilities
- facilitate ongoing research and investigation of new initiatives.

2.2.3 Local Strategic Bicycle Plan

Local strategic bicycle plans can be developed on a municipal basis or a regional basis where a number of municipalities share resources. The purpose of these plans is to translate many of the aims of the state-wide strategy into practical programs and projects at the local level.

Local strategic bicycle plans should, however, concentrate on the development of solutions to problems that exist within the municipality or region rather than deal with general issues. Local strategies should be aligned with State or Territory priorities and National objectives.

The actions required to develop local strategic bicycle plans would usually include:

- a survey of the extent and nature of cycling within the municipality or region
- determination of the cycling requirements of the community
- identification of factors that inhibit cycling
- identification of a practical bicycle route network with appropriate links to adjacent regions or networks
- development of engineering measures and programs to overcome problems including estimated costs, time frame and an implementation plan
- development of a bicycle network support requirements (e.g. bicycle parking, kerb ramps, drinking water fountains, signage)
- development of encouragement and other appropriate behavioural programs, with an aim of increasing the use of cycling facilities as well as the safety of cycling, in the local area
- review of law enforcement and compliance with local bylaws
- review of the requirements for development applications in regard to cycling (e.g. bicycle parking and shower facilities)
- review of construction and maintenance practices and education of staff responsible for these tasks, so they accommodate the needs of cyclists in their work (e.g. landscaping, roadworks and irrigation).

For the community to derive maximum benefit from its local strategic bicycle plan it is essential that the plan produce positive, practical and affordable outcomes that meet user needs.

It is suggested that the development of local strategic bicycle plans should be overseen by a steering committee comprised of representatives of:

- local government
- local government engineering, urban planning and recreation staff
- the state road agency
- the police
- local schools
- cyclists
- bicycle industry
- local industry
- the local community.

States and Territories have a role to ensure that local strategies complement each other to create a State or Territory network through means such as the development of local bike plan guidelines.

2.3 Integrated and Multi-modal Planning

Bicycle planning needs to consider that transport planning will be at its most effective if it is integrated with other types of planning. Planning in sectors such as transport, regional development, health and education should be considered to ensure decisions complement rather than conflict with each other. Consistent land-use planning decisions also need to be made across regions and jurisdictions (Austroads 2009i).

Multi-modal transportation planning is a multi-faceted approach that considers all modes/options. The bicycle network needs to be separated from, yet integrated with the main road, pedestrian and public transport systems. This will necessitate regular crossings in order to sustain the coverage and continuity of the network for cyclists.

The actual measures which can be adopted to facilitate movement will be influenced by functional road hierarchy considerations such as the access and movement functions of the road. Cycling facilities can be provided more cost-effectively by planning and making provision for these facilities as part of larger initiatives. Note, however, that facilities will also often be shared between cyclists and other modes such as motorised traffic.

For further guidance on integrated and multi-modal planning, practitioners are referred to the *National Guidelines for Transport System Management in Australia Volume 2* (Australian Transport Council 2006).

2.4 Bicycle Network Management

2.4.1 Introduction

This section is based on the GTM 4 (Section 4.6) which covers traffic management at a network level. It addresses network needs of the various categories of user (including cyclists), the characteristics of various types of network and, importantly, describes a planning process for balancing or prioritising the competing needs of different users.

2.4.2 Purpose of a Bicycle Network

The purpose of a bicycle network is to enable cyclists of a wide range of abilities and experience to move safely and conveniently to chosen destinations via suitable desire lines. The basis of a bicycle network is the road network, augmented by special on-road facilities together with dedicated infrastructure such as off-road paths, and footpaths where permitted, and may include public transport. Table 2.2 details features that are important to form a good bicycle network.

Table 2.2: Bicycle network features

Route feature	Comments
Safety	Minimal risk of traffic-related injury, low perceived danger, space to ride, minimum conflict with vehicles.
Coherence	Infrastructure should form a coherent entity, link major trip origins and destinations, have connectivity, be continuous, signed, consistent in quality, easy to follow, and have route options.
Directness	Route should be direct, based on desire lines, have low delay through routes for commuting, avoid detours and have efficient operating speeds.
Attractiveness	Lighting, personal safety, aesthetics, integration with surrounding area, access to different activities.
Comfort	Smooth skid-resistant riding surface, gentle gradients, avoid complicated manoeuvres, reduced need to stop, minimum obstruction from vehicles.

Source: Austroads (2014a) Table 4.11.

2.4.3 Functions of a Bicycle Network

There should be a relationship between the functions of the component parts of a bicycle network and the functions of the road network hierarchy. Where bicycle routes run along or cross the road network, the operational facilities should reflect the network functions for both the road and the bicycle route cycleway. Table 2.3 relates the bicycle network hierarchy to the purpose for which it will be used.

Table 2.3: Bicycle network functions

Network	Network function	Cyclist operating speed
Regional bicycle network ⁽¹⁾	High-quality, high-priority routes to permit quick, unhindered travel between the major regions of cities, towns or urban areas.	25–40 km/h
Local bicycle routes	High-quality routes with seamless connections to regional routes. These routes connect the local street system to the major regional routes.	20–30 km/h
Mixed traffic streets (door to door access to all destinations)	Low speed, low volume local access to residential destinations in 'low-stress' shared environments.	< 20 km/h

¹ Principal or strategic bicycle network in some jurisdictions.

Source: Austroads (2014a) Table 4.13. Based on Roads and Traffic Authority NSW (2005).

2.4.4 Objectives of a Bicycle Network

The objectives outlined in Section 4.6.4 of GTM 4 that are relevant to the planning, design and operation of bicycle networks include:

- a designated regional network of roads and paths that serves longer-distance commuter and recreational trips
- designated local networks and routes designed to provide low-stress routes, to feed the regional network and to provide for shorter local trips to shopping centres, recreational activities, public transport hubs
- full construction of route sections between origins and destinations consistent with the route purpose
- convenient access into and through residential, commercial and industrial subdivisions, and major developments
- access and facilities to travel with a bicycle on public transport
- secure long and short-term parking facilities at major destinations
- safer routes to schools
- well-defined bicycle facilities on arterial roads where significant cyclist demand exists including specifically for commuter trips
- appropriate maintenance practices which result in smooth surfaces
- calming in local streets
- paths which are interesting, that include rest areas at appropriate intervals on regional routes, and are designed to appropriate geometric standards
- implementation of regulatory, warning and guidance signage on paths.

2.4.5 Network and Route Mapping

As with any transport system, accurate and comprehensive information concerning the bicycle network is essential. Maps should be available to cyclists showing the route, facilities and points of interest including the relationship to the surrounding road system and community facilities. The scope of bicycle route and network maps can be local or regional but should always adopt a network approach and aim to present through routes and access locations.

The Australian Bicycle Council website (refer to Appendix B, www.bicyclecouncil.com.au) provides a number of examples of bicycle network and route mapping.

2.4.6 Categories of Cyclists and their Network Requirements

Cyclists are diverse in their needs and may fulfil a number of needs on a single trip. Seven groups of cyclists have been identified, each with specific riding characteristics and network requirements (Section 4.6.2, GTM 4). There is usually a need to cater for more than one group in any corridor. The groups are discussed in Table 2.4.

Table 2.4: Categories of cyclists and their characteristics

Category	Rider characteristics	Riding environment
Primary school children	Cognitive skills not developed, little knowledge of road rules, require supervision.	Off-road path, footpath (where permitted) or very low volume residential street.
Secondary school children	Skill varies, developing confidence.	Generally use on-road facilities or off-road paths where available.
Recreational	Experience, age, skills vary greatly.	Desire off-road paths and quiet local streets, avoid heavily trafficked routes, more experienced will prefer to use road system for long journeys.
Commuter	Vary in age, skill and fitness, some highly skilled and able to handle a variety of traffic conditions.	Some prefer paths or low-stress roads, willing to take longer to get to destination, others want quick trips regardless of traffic conditions, primarily require space to ride and smooth riding surface, speed maintenance.
Utility	Ride for specific purposes (shopping), short length trips, routes unpredictable.	Not on highly trafficked roads, needs include comprehensive, low-stress routes, appropriate end-of-trip facilities.
Touring	Long distance journeys, may be heavily equipped, some travelling in groups.	Often route is similar to that of other tourists.
Sporting	Often in groups, two abreast occupying left lane, needs similar to commuters.	Travel long distances in training on arterials, may include challenging terrain in outer urban or rural areas, generally do not use off-road routes because of high speed and conflict with other users.

Source: Austroads (2014a) Table 4.12.

2.5 Bicycle Programs

Bicycle programs are concerned with both transport network improvements and behavioural issues. The objective is to make cycling safer, more convenient and hence an attractive alternative means of transport. Programs generally address issues relating to education, encouragement, enforcement and engineering but these four Es should usually be regarded as inter-related components of the same program, rather than separate programs. For example, as a network of bicycle routes is developed within a city or town (Engineering) it will be necessary to:

- promote it through advertising, pamphlets and maps (Encouragement)
- teach people who use it how to ride safely and courteously (Education)
- insist that relevant laws and regulations be obeyed for the benefit of all users (Enforcement).

An example of a bicycle network evaluation from the GPE 8 can be found in Appendix A.

2.5.1 Behavioural Aspects Programs

Bicycle programs will include consideration of many issues relating to the behaviour of cyclists, safer use of the transport network, and the encouragement of cycling. Sub-programs should be developed to address these issues and initiatives that might be taken are listed below. Whilst many of the initiatives are inter-related, for convenience they are divided into Education, Enforcement and Encouragement.

Education programs

Initiatives relating to the education of the community regarding cycling may include:

- bicycle safety education programs in primary schools
- bicycle safety education programs in secondary schools including development of on-road skills
- courses for inexperienced adult cyclists
- development of a cyclist code of behaviour
- ongoing education of motorists and cyclists to better understand each other's needs
- media campaigns on critical issues.

Example of behavioural aspects program (GRS 4)

In New Zealand there is a growing overlap in encouragement of sustainable transport choices (and mode choice for alternative forms of transport, away from cars) and road safety issues. Promotion of options by both central government and locally by the Rotorua District Council (RDC) is seen as an important move. This project aims to encourage those that may not have the skills, motivation or means to cycle, to learn to do so under controlled, local conditions. It supports this by providing safer cycling facilities.

This project involves advertising and running regular community based cycling courses which include bike maintenance, cycling tuition and instruction on road rules, rights and obligations (usually police). Cycling skills are practised off-road at first, then the group graduates to an on-road site nearby.

An example of the on-road environment is shown in the figure below. Safer on-road cycling facilities have been specially constructed to include cycling infrastructure not usually supplied on low volume roads. This includes interpretive billboards for cyclists, marked cycle lanes, advance cycle boxes at intersections (different types), and a roundabout. Infrastructure was provided by RDC; bike mechanics were supplied by local cycle stores; police provided instructors, and several agencies advertised the project.

Figure 2.1: On-road instruction in safe cycling procedures



Source: From Austroads (2009j).

The success of the project is to be evaluated by the number of participants, participant feedback, the numbers of cyclists using the road network, and by the safety of the road network for cyclists.

Enforcement programs

Bicycles are defined as vehicles under road traffic regulations and cyclists are therefore required to comply with the law. However, police involvement in cycling should be more constructive than simply penalising offenders. Initiatives relating to enforcement may include:

- seminars to educate police in the role they can play in bicycle strategies and plans to improve cycle safety
- ongoing media promotion of laws, responsible and defensive riding, etc.
- promotion of safer cycling by personal contact with young and adolescent cyclists
- development of police patrols on bicycles in inner city areas and on busy paths
- special promotional campaigns with rewards for safer cycling (e.g. raffle of cycling goods)
- a police-in-schools program as part of general traffic safety education, including bicycle safety checks and basic road law.

Encouragement programs

A major objective of bicycle programs is to achieve increased levels of community participation in cycling for both transportation and recreation. Initiatives to encourage cycling may include:

- ongoing promotion of the environmental, recreational and health benefits of cycling to the individual and community
- promotion of the opportunities of using the bicycle for recreation, tourism, commuting, social and practical purposes
- development of systems, fare structures and other conditions to make multi-modal travel (e.g. bicycle/train) an attractive alternative to the motor car for appropriate trips
- individualised marketing campaigns such as travel demand management programs
- the organisation of special bicycle rides and other events such as national conferences
- provision of a comprehensive set of education programs
- development of comprehensive engineering programs to provide networks, continuous routes, safer and smoother roads and paths
- provision of adequate end-of-trip facilities such as showers and secure parking
- introduction of 'change time' to allow employees to book a certain amount of time to showering and changing when commuting using a bicycle
- provision of information, maps and signs to guide cyclists to appropriate routes and facilities.

2.6 Traffic Studies and Bicycle Surveys

The provision of facilities for cyclists has been steadily increasing due to an increased focus on user needs and safety. Data on some of the movements made by cyclists can be collected using methods similar to those used for collecting other traffic data (see Appendix B and GTM 3 for more detail on designing surveys). The nature of bicycle movements, however, is not as restricted to specific roadways as that of vehicles, hence the greater difficulty in collecting information. Bicycles are defined as vehicles under road traffic regulations and therefore have a right to use virtually all roads.

Studying bicycle movements may also be complicated by the spatial distribution of routes they can choose. For example, cyclists can easily reverse their direction of travel and exit a system where they enter. The main similarities between motor vehicles and cyclists occur when cyclists are constrained to a footpath, road lane or corridor, as this situation is similar to vehicles on a road.

Any study of cyclist behaviour requires a clear statement of the problem to be addressed and a statement of the objectives of the study. This statement should lead to a set of parameters to be measured by the study. The Australian Bicycle Council (2000) recommends that base data be collected in study areas that are consistent with the geographic areas used by the Australian Bureau of Statistics, so as to ensure consistency with population characteristics.

The majority of data collected in bicycle surveys will come from sample surveys. When deciding on the size of the sample, it is necessary to consider confidence limits, levels of confidence and inherent variability. A trade-off exists between the required accuracy of the sample, and therefore the size of the sample, and the cost of the study.

The sampling of cyclists is difficult because information on bicycle ownership is rarely available. The concentration on particular groups such as school children or bicycle clubs will also not provide information on all bicycle users. Interviewing in the field may provide an overall idea of travel characteristics but survey locations need to be selected carefully and in a random manner to ensure a broad spectrum of cyclists is interviewed.

Various ongoing household travel surveys exist, and useful data on bicycle trips can be obtained from them. They include the *Victorian Integrated Survey of Travel and Activity* (Victoria Department of Transport 2009) and the *Sydney Household Travel Survey* (Bureau of Transport Statistics 2012). The surveys record daily travel patterns, including bicycle and walking trips, of household members in Melbourne and Sydney respectively. Other databases such as the Bicycle Imports of the Bicycle Industries and Traders Association and the Serious Injury Database of the Australian Transport Safety Bureau also provide useful bicycling and pedestrian data.

When using existing information, it is necessary to consider the original purpose of the data, the represented population (e.g. were children under ten included?), the treatment of multi-mode trips and the sampling techniques used.

2.7 Type of Bicycle Facility Required

When considering the type of bicycle facility, such as bicycle lanes or shared use paths, the two guiding principles are separating cyclists from motor vehicles and providing a high level of priority for cyclists across driveways and through intersections (Section 4.6.5, GTM 4).

Figure 2.2 provides an example of guidelines for the selection of an appropriate type of bicycle facility. It relates the degree of separation required for cyclists to the speed and volume of general traffic. It should, however, be noted that jurisdictional policy and implementation strategies may also influence selection of particular facilities.

A key message of Figure 2.2 is that the separation of cyclists from motor vehicles is not always required on local and collector roads that have traffic volumes less than 5000 vehicles per day and speeds less than 40 km/h. In these circumstances, it is considered appropriate that adult cyclists may share the road with motor vehicles and younger cyclists may use the footpath where this is supported by appropriate road rules.

However, where space permits, it is still important to consider the provision of a separated bicycle facility such as a bicycle lane or a shared use path.

Road authorities should aim to comply with this guidance, particularly in greenfield situations, but the outcome may not always be optimal in retro-fit situations. In addition, note that experienced road cyclists are unlikely to use off-road facilities with low design speeds, even on routes where the road carries high volume, high speed traffic. On-road bicycle lanes or suitable road shoulders may still be required in addition to off-road facilities.

More detailed guidance on the selection of particular types of on-road and off-road bicycle facilities can be found in Table 3.2 of GTM 5.

Figure 2.2: Separation of cyclists and motor vehicles by speed and volume

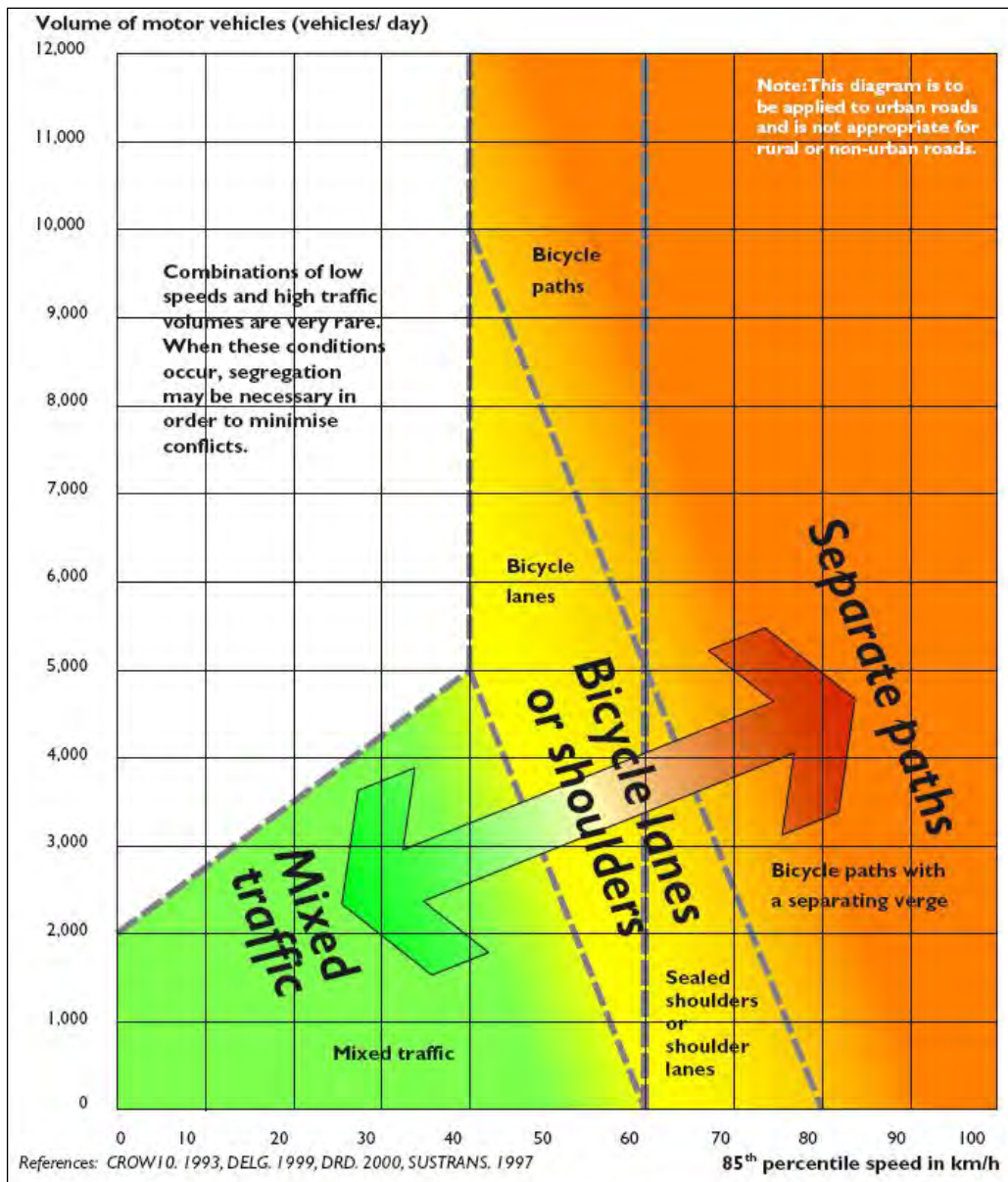

Source: Austroads (2014a) Figure 4.7, and Roads and Traffic Authority NSW (2005) Figure 3.2.

2.8 Combining Bicycle Travel with Public Transport

The combination of multi-mode travel where people cycle to interchanges and transfer to public transport can substantially increase the range of bicycle travel. Public transport authorities should make provision for carriage or storage of bicycles in conjunction with the inclusion of transport hubs as specific destinations within the bicycle route network (Section 4.6.8, GTM 4).

Examples of such provision can include easy-to-use on-board storage facilities, easy access to stations with secure long-term weatherproof parking or parking rails for short-term parking. Parking facilities are discussed in Section 11 (of this document) and Section 7.8.5 of GTM 11.

The Australian Bicycle Council website (Appendix B, www.bicyclecouncil.com.au) provides a number of examples of methods for integrating cycling and public transport, as well as examples of successful programs.

2.9 Local Area Traffic Management

Guidance for cycling facilities in local areas is provided in GTM 8.

Bicycle lanes (Figure 2.3) are not often needed in local areas where the speed environment is low and the mixture of bicycle and vehicle traffic works well together.

Advisory treatments are provided to indicate or advise road users of the potential presence of cyclists and of the location where cyclists may be expected to ride on the street. They consist of pavement markings and warning and guide signs, and as such have no regulatory function. As with bicycle/car parking lanes, collisions between cyclists and opening doors of parked cars are a significant concern to cyclists. The purpose of these treatments is usually to define a bicycle route rather than a type of facility to which specific road rules apply. The form of the treatment is a matter for local jurisdictions.

Bicycle bypasses provide a safer and more comfortable mechanism for cyclists to avoid passing through devices. They are desirable where there is a need to separate cyclists from other traffic to make routes more attractive for travel or to avoid squeeze points, adverse surface conditions, and other obstacles. The design of bicycle bypasses should be done in such a way that they take the cyclist past the device to a separated space or they allow safer reintegration with motorised traffic.

Figure 2.3: Bicycle lane example



Source: *Guide to Traffic Management* (Austroads 2008a) Figure 7.32.

Other bicycle facilities that may be appropriate in local areas include contra-flow bicycle lanes, wide kerbside lanes, bus/bicycle lanes and supplementary street treatments (refer to Section 4 of this document and GRD 4). Table 2.5 describes the use, advantages and disadvantages of bicycle lanes, advisory treatments and bypasses in LATM treatments whilst Figure 2.4 shows examples of treatments. Further information on the provision and design of bicycle lanes, advisory treatments, bypasses and other facilities is provided in Section 4.9 of this document.

Table 2.5: Use, advantages and disadvantages of bicycle lanes, advisory treatments and bypasses in LATM schemes

Use	Advantages	Disadvantages
<p>It is appropriate to use bicycle lanes, advisory treatments, and bypasses:</p> <ul style="list-style-type: none"> ▪ where there is a significant difference in the speed of vehicular and bicycle traffic (i.e. > 20 km/h) ▪ where it is desirable to separate cyclists from other traffic (e.g. for reasons of safety) ▪ anywhere cycling needs to be encouraged (e.g. along major routes near town or city centres). <p>It is inappropriate to use bicycle lanes, treatments and bypasses where they will restrict the movement of buses.</p>	<p>The advantages of bicycle lanes, advisory treatments and bypasses include:</p> <ul style="list-style-type: none"> ▪ increase in cyclist safety ▪ improvement in accessibility and connectivity of the bicycle network ▪ they can be used to narrow the width of traffic lanes ▪ they promote the use of alternative modes of transport. 	<p>The disadvantages of bicycle lanes, advisory treatments and bypasses include:</p> <ul style="list-style-type: none"> ▪ separate facilities may be expensive ▪ facilities may be incompatible with other LATM devices.

Source: Austroads (2008a) based on Section 7.5.11.

Figure 2.4: Examples of bicycle bypasses of LATM devices



City of Gold Coast, Queensland

Source: Austroads (2008a) Figure 7.33.



City of Unley, South Australia

2.10 Traffic Management in Activity Centres

2.10.1 Planning Context for Cycling in Activity Centres

Austroads GTM 7 considers the requirements of cyclists in the overall planning of activity centres and practitioners should refer to GTM 7 for further information.

The key planning principle for bicycle travel in relation to activity centres is typically to maximise cyclists' accessibility to centres, services, facilities and employment locations.

Bicycle access to destinations within the centre will comprise the terminal part of a journey. The scale and the nature of the roads and streets through an activity centre will determine the extent to which defined bicycle routes will be required within it. While approach routes to key foci such as a railway station will need to be defined and enhanced, it may not be necessary to provide for designated bicycle access to every possible destination. Deciding on where bicycles can be parked, and how bicycles get to those points, is part of the traffic management task.

Planning for bicycle travel and access is a high priority in all jurisdictions. As a component of sustainable transport policies, bicycle use must be actively encouraged in the planning, design and management of a centre. There are many government policies and guidelines on this subject, and these local sources should be consulted. Typical guiding principles and criteria for bicycle planning are shown in Table 2.6. Where appropriate, these will also influence the management of bicycle movement within centres.

Table 2.6: Example of guiding principles and criteria for bicycle plans

Principle	Criteria
Coherence	Continuity of routes Consistent quality of routes and facilities Easy to follow Freedom of choice of routes
Directness	Efficient operating speed Delay time Detour factor*
Safety	Minimum risk of accidents on routes Minimum risk of conflict with car traffic Minimum risk of unsafe infrastructure
Attractiveness	Support for the system Attractiveness of environment Perception of social safety System attractiveness
Comfort	Smoothness of ride Comfortable gradient Minimum obstruction from vehicles Reduced need to stop (number of stops per km) Protection from adverse climate
End-of-trip facilities	Provision of secure bicycle parking in convenient locations Provision of change facilities for commuters/workers

* Detour factor is the actual route length on the road/bicycle network divided by the distance measured in a straight line between the trip origin and the trip destination. Source: Austroads (2009a) Table 2.4, based on Roads and Traffic Authority NSW (2005).

Inevitably, there will be a degree of compromise within many activity centres, for instance in terms of stops and delays. Traffic management also needs to allow for the reality that bicycles are not compatible with pedestrian spaces, especially where pedestrian movement is moderate to intense, and to that extent the two modes must be considered separately in detailed design and management of the centre. In addition, it is not generally expected that bicycle movement from one part of the centre to another must always be accommodated in planning and management.

Matters concerning planning for bicyclists in centres that may impact on traffic management include the following:

- provision for direct and convenient bicycle access into the centre from surrounding areas, and thus the way in which the centre's internal networks integrate with routes used by cyclists to access the centre
- provision for bicycle movement through the centre and to bicycle parking/storage locations, which will affect road cross-section design, and the location of bicycle parking facilities and how access to them is provided
- bicycle parking arrangements, especially at places of employment and at rail stations.

2.10.2 Bicycles in Activity Centres

In order to satisfy policy intentions that positive steps are to be taken to encourage bicycling, and to provide the necessary physical conditions, traffic management can play a supportive role to the planning and urban design measures that are taken (Section 3.8.3, GTM 7). The key objectives, from a traffic management point of view, are to:

- maximise cycling accessibility to centres and the services, facilities and employment they contain
- design streets that comfortably and safely accommodate cyclists
- ensure that vehicle traffic does not compromise a good cycling environment
- ensure that cycling does not compromise a good walking environment.

A number of issues related to bicycles in activity centres arise from these objectives, which traffic management can influence or determine:

- bicycle planning as it relates to activity centres
- bicycle access within the centre
- bicycle facilities
- interaction with pedestrians
- interaction with other traffic
- bicycle parking.

2.10.3 Cycling Implications for Traffic Management Practice in Activity Centres

The following guidance on these matters is derived from the Department of Infrastructure, Planning and Natural Resources (2004); Department of Urban Affairs and Planning (2001); Roads and Traffic Authority NSW (2005).

Bicycle planning for activity centres

Implications include:

- Cycling catchments can be mapped in the same way as pedestrian catchments. As bicycles travel three to four times faster than a person on foot, the bicycle catchment for a five-minute ride is around 1.5 km. This potentially puts a large population within easy reach of the centre. Path detours can be calculated to identify indirect paths that need attention.
- Ideally, the centre will have a 'transport plan' (or 'mobility and access plan'), which forms the basis of bicycle provisions and management in the centre.
- Bicycle plans are not static, but are continually updated and considered in all planning and management processes and work programs.
- Bicycle (and pedestrian) plans for the centre are integrated with planning instruments to give them legal and policy effect.
- Conversely, traffic management, pedestrian and town centre improvement plans are aligned with bike plans to ensure that cyclist facilities and routes complement the physical form and needs of the centre.
- Public transport stops or nodes and local services, including primary schools, are co-located in and around local centres to maximise trip efficiency.
- Audits of 'bikeability' will assist in identifying elements of bicycle infrastructure that need attention (Bicycle Federation of Australia 2007, Cluster for Physical Activity and Health 2007; Pedestrian and Bicycle Information Center 2008).

Access within the centre

- Within the centre, bicycle access should be safe, direct and comfortable between different locations.
- Some judgment is required to decide if cycling is to be expected (and catered for) between every destination within the centre. (See following remarks concerning bicycle parking.)

Bicycle facilities in activity centres

- The primary aim is to create traffic conditions (primarily speeds) within the centre that are compatible with bicycle use on the same carriageway. Thus, measures to reduce the volume and speed of traffic should be considered first. These may reduce the potential for conflict sufficiently and thus minimise or even avoid the need for separate provisions for bicycles on the centre's streets.
- Where slow speeds and low volumes cannot be achieved, or depended upon, dedicated bicycle lanes can be considered where appropriate under bicycle planning guidelines (see GTM 5 and 6). It will rarely be feasible or appropriate to provide separate bicycle paths within activity centres.
- Employ suggested guidance on bicycle facility selection, design, signing, integration with public transport and end-of-trip facilities (Roads and Traffic Authority NSW 2005; GTM 4, 5, 6 and 10).
- Clearly signpost off-street car parks, bicycle paths, public transport stops and footpath connections.

Interaction with pedestrians in activity centres

Many of the principles for walk-based activity centres (Section 2.3.2, GTM 7) apply to cycle access and circulation. However, bicycles and pedestrians can be an uncomfortable mix in some circumstances. Therefore, some degree of separation is often justified:

- In pedestrian activity spaces, bicycles can be threatening and intrusive. It may be necessary to avoid shared paths and surfaces in the centre, where the volume of pedestrian traffic will usually be too great for cycling to be safely and comfortably accommodated. For example, it would not be appropriate to allow a footpath to be shared by pedestrians and cyclists along a ribbon/strip style shopping area along an arterial road.

Interaction with other traffic

- Create slow-speed conditions on streets where cyclists mix with traffic within the centre.
- Exploit opportunities to use streetscaping, pedestrian and cycling facilities, and parking layouts to help restrain vehicle speeds.
- Manage traffic volumes and lower speeds through traffic calming, parking design and intersection design measures (see GTM 8).
- Where appropriate, introduce shared zones (see Section 3.6 of GTM 7).
- As noted above, separate bicycle lanes can be considered where it is unsafe for cyclists to share the road with motorised traffic.
- Whatever arrangement for integration with, or separation from, vehicular traffic is adopted, there should be no ambiguity about where the cyclist and other road users are situated on the road and what their mutual obligations and expectations are.
- Consider the needs of cyclists in designing intersections. Cycle road crossings are an integral part of cycle routes, and intersection and crossing design should favour cyclists' convenience and safety within centres.

Bicycle parking in activity centres

Not all bicycle parking needs are the same. Bicycle parking facility design should reflect the needs of several different cycling trip types (Roads and Traffic Authority NSW 2005):

- Collection and delivery of items: Providing 'ride-in' facilities may reduce the risks caused by bikes clustered around entrances to buildings or lying on pavements. Parking for such short stay users does not necessarily need to be highly secure, but should be near the entrance, or inside, the place visited.
- Shopping-type visits: Racks should be located at regular intervals to ensure that the bike is reasonably close to the destination and under observation.
- Meetings and appointments: Use is generally irregular and can be long-stay – up to a whole day. Users favour locations where lighting and surveillance are perceived to be good, usually at or near to main building entrances.
- Further guidance on bicycle parking is provided in Section 11 of this document and GTM 11.

2.11 Traffic Impacts of Developments

Depending on the nature and scale of a development, cyclists will access it via the adjacent road system from more distant locations, from nearby residential areas or from nearby bicycle routes. Where there are nearby bicycle facilities (off-road bicycle paths or on-road bicycle lanes) bicycle links into the development need to be considered. Convenient, safe and attractive cycle access should be provided.

GTM 12 is designed to help traffic and transport practitioners identify and manage the impacts on the road system arising from land use developments, and contains information on the consideration of cyclist needs in assessing access requirements to and within developments.

Secure bicycle parking is an essential part of a network of bicycle facilities. Bicycle parking needs to be provided in a location that is convenient, and visible to the public for security reasons. In some planning schemes there are specific requirements for bicycle parking at developments in particular land use zones. Australian Standard AS 2890.3:1993 outlines the requirements for bicycle parking. Parking facilities are discussed in Section 11 of this document and GTM 11.

3. Bicycle Rider Requirements

3.1 General

The basic bicycle rider requirements that are generally considered necessary for convenient, efficient and safe travel by bicycle are presented in this section. Information on rider requirements is provided in GRD 3 (Commentary 9) and in GRD 6A (Section 4). Specific sections of these guides relevant to this section are shown in Table 3.1.

Table 3.1: Key cross-references related to bicycle rider requirement

Section of <i>Cycling Aspects of Austroads Guides</i>					
Guide	Section	Reference source	Guide	Section	Reference source
Section 3.1: General					
	Commentary 9.1	Austroads (2010b)		Section 4.2	Austroads (2009f)
Section 3.2: Space to Ride (also Sections 4.2.3 and 7.5)					
	Commentary 9.2	Austroads (2010b)		Section 4.2	Austroads (2009f)
Section 3.3: Smooth Surface (also Section 10.2 and Appendix E.4)					
	Commentary 9.3	Austroads (2010b)		Section 4.2	Austroads (2009f)
	General	Austroads Guides		Section 5.2.6	Austroads (2013e)
Section 3.4: Speed Maintenance (also Section 7.5.2)					
	Commentary 9.4	Austroads (2010b)		Section 4.2	Austroads (2009f)
Section 3.5: Sight Lines (also Sections 4.2 and 7.5.8)					
	Sections 4.2 and 7.8	Austroads (2009f)		Section 5	Austroads (2009d)
	Section 3	Austroads (2010a)			
Section 3.6: Connectivity (also Section 4.2)					
	Commentary 9.5	Austroads (2010b)		Section 4.2	Austroads (2009f)
Section 3.7: Information (also Sections 2.4.5 and 9.2.1, and Appendix D)					
	Section 4.2	Austroads (2009f)			

Notes:



Guide to Road Design (GRD)



Guide to Pavement Technology (GPT)

A very important requirement of many cyclists, in addition to those described below, is separation from motor vehicles because it enhances their safety and comfort, provided that the treatment results in a satisfactory level of service and does not result in a loss of priority at intersections and driveways. Commuter cyclists, for example, are unlikely to use a separated facility that results in a significantly greater travel time than alternative on-road routes.

3.2 Space to Ride

The bicycle design envelope and clearances shown in Figure 3.1 provide the basis for the design of the bicycle facilities described in later sections of this document. It is important for designers to understand the basis of the design including clearance requirements so that they can make judgements in difficult situations where knowledge of minimum space requirements is needed. The envelope is relevant to the design of lanes on roads, off-road paths and bicycle parking facilities.

Figure 3.1: Cyclist envelope

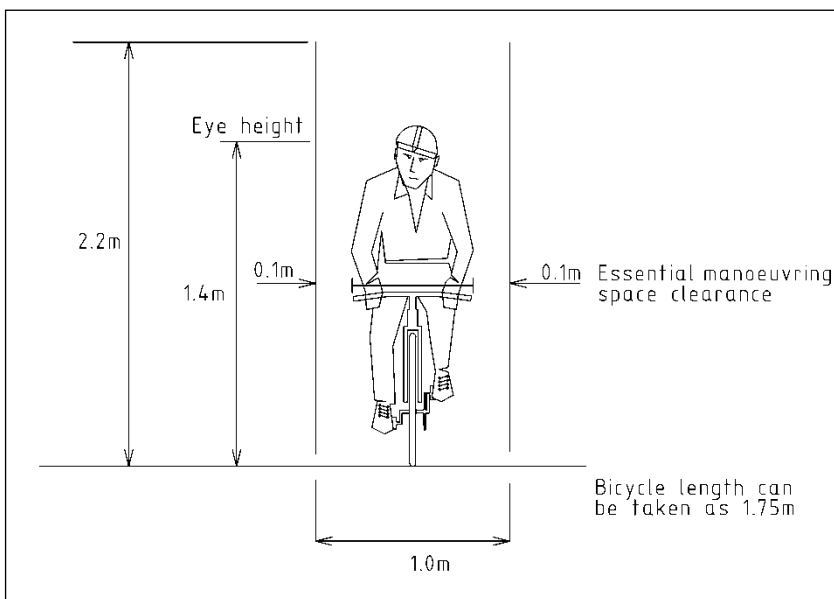

Source: Austroads (2010a) Figure 4.18.

The 1.0 m wide envelope allows for the width of a bicycle and for variations in tracking. Not all bicycle riders can steer a straight line and when riding up-hill experienced riders work the bicycle from side to side whilst the inexperienced may wobble. Bicycle riders also need adequate clearances to fixed objects and to passing vehicles in addition to the 1.0 m envelope.

In some situations it may be appropriate to provide for alternative forms of pedal cycles in the design of facilities. With reference to Appendix D operational characteristics and advice on the means of designing for 'human powered vehicles' (HPVs) are provided in the event that a route or facility is anticipated to be used by a large number of these vehicles.

In general the least manoeuvrable HPV served by these guidelines is a tandem bicycle.

3.3 Smooth Surface

Many bicycles have narrow tyres inflated to high pressure to reduce drag and have no suspension system. A smooth (albeit skid resistant) surface is therefore desirable for bicycles to be used effectively, comfortably and safely. Surfaces used for cycling should desirably be smoother than those acceptable for motor vehicles and persons responsible for road and path construction and maintenance should be made aware of this requirement. Detailed advice on surface tolerances is provided in GRD 6A. Also, designers should be aware of the potential for debris to wash onto paths from adjacent land and that this can negate the provision of a smooth surface. Designs should minimise the likelihood of debris washing onto paths. For further guidance on the maintenance of cycling facilities and pavements, refer to Section 10 of this document.

Bovy and Bradley (1985) found that surface quality and trip length were about equal in importance and both were twice as important to cyclists as traffic volumes and the availability of bicycle facilities in cyclists' route choice.

3.4 Speed Maintenance

For bicycles to be most effective as a means of transport cyclists must be able to maintain speed without having to slow or stop often. Cyclists typically travel at speeds between 20 km/h and 30 km/h although they may reach in excess of 50 km/h down hills. Once slowed or stopped it takes considerable time and effort to regain the desired operating speed.

Bicycle routes, especially off-road, should be designed for continuous riding, minimising the need to slow or stop for any reason including steep gradients, rough surfaces, sharp corners, obscured sight lines, intersections, or to give way to other people because the width available is too narrow. On many roads cyclists are confined to the extreme left-hand side by motor vehicles and a rough surface prevents cyclists from maintaining an acceptable speed.

3.5 Sight Lines

It is important that appropriate sight lines are provided between a cyclist's eye height and pedestrians to assist in minimising conflict, and between a cyclist's eye height and the path surface so that cyclists can stop in the event that a hazard exists on the path (e.g. mud deposited during inundation, potholes due to washouts, broken glass, and fallen tree limbs).

Designers should ensure that roads are designed to meet the sight distance requirements of Section 5 of GRD 3 and Section 3 of GRD 4A. Paths should be designed to meet the sight distance requirements of GRD 6A, also refer to Section 7.5.8 of this document.

Designers should therefore resist the temptation to provide curves that are smaller than necessary (e.g. to create an artificially winding path for aesthetics or urban design reasons). It is much better for the safety of path users if larger curves with greater sight distance are provided.

3.6 Connectivity

Connectivity is that quality of a bicycle route or route network, describing the continuous nature of facilities or of the continuous nature of desired conditions. Practitioners should refer to Commentary C9, Section C9.5 of GRD 3 and Section 4.2.1 of GRD 6A for further information on connectivity.

Cyclists need to be able to undertake and complete meaningful trips by bicycle. For recreation it may be from a residential area to a picnic spot, or for a specific purpose trip from home to work or the shops. Bicycle routes comprising roads and paths should combine to form an effective, convenient and safe network.

Connectivity is an important aspect of the construction of effective bicycle routes. Before a route is constructed the purpose of the route should be identified as well as the routes which cyclists are likely to use in travelling to and from the paths, bicycle lanes and roads forming the network.

A route for cyclists which starts and ends abruptly is undesirable and may be hazardous as it may lure inexperienced cyclists to a point where they are at risk, perhaps having to ride along or across busy roads to complete their intended trip.

On-road bicycle facilities may take the form of (refer to Section 4 of this document):

- dedicated unprotected bicycle lanes including full-time or part-time operation with or without adjacent parking
- contra-flow bicycle lanes
- protected bicycle lanes using kerbs and medians to physically separate motor vehicles and cyclists
- wide sealed road shoulders
- advisory treatments
- wide kerb-side motor vehicle traffic lanes.

Off-road bicycle facilities may take the form of (refer to Section 7 of this document):

- exclusive bicycle paths
- separated paths – bicycle and pedestrian
- shared use paths.

3.7 Information

Bicycle routes should be signposted to indicate both destinations and the distances to them.

Maps should be available showing the route, facilities and points of interest along it, its relationship to the surrounding road system, and its relationship to relevant community facilities. The map and the signposting should be consistent in terms of destination names and other information.

4. Bicycle Facilities On-road (Mid-block)

4.1 General

The ultimate aim in the management of a road network or individual road length is to achieve a balance in the competing needs of road user groups. It is desirable (although not always possible) that a road design should provide adequate operating space and appropriate treatments for all road users so that they can move safely and efficiently throughout the network.

The *Guide to Road Design – Part 3: Geometric Design* (Austroads 2010b) provides guidance on the facilities that may be provided for cyclists within a road cross-section. Other related Austroads guidance is summarised in Table 4.1.

4.1.1 Types of On-road Bicycle Facilities

In local streets it is usually not necessary to make special provision for cyclists as the lower speed of motor traffic should enable cyclists to safely share the road with other users. On arterial roads and collector roads it is usually necessary to ensure that adequate space exists for cyclists to share the road safely and comfortably, particularly when the road forms part of a principal or regional bicycle network. It may be possible to reduce the widths of other lanes in order to allocate additional space to the left hand lane for joint use by cyclists.













Depending on the nature of the road, abutting land use, the function of the road in bicycle networks, and the number and types of cyclists using the road, the following types of on-road facilities may be considered for inclusion in a road cross-section. Moreover, the provision of cyclist facilities should be based on the hierarchy of needs, delivered in order of level of safety and priority (GRD 3):

1. off-road exclusive bicycle path (within the road corridor)
2. on-road segregated bicycle lanes – median or similar separation
3. on-road exclusive bicycle lane
4. on-road peak period exclusive bicycle lane
5. on-road bicycle/car parking lane
6. wide kerbside lane
7. narrow kerbside lane.

The facilities described in this section are those applied within the carriageway of new roads or within the established road carriageway in the case of existing roads.

Off-road bicycle facilities typically take the form of shared pathways for use by both cyclists and pedestrians, and these are described in more detail in Section 7 of this document, and GRD 6A.

Table 4.1: Key cross-references related to bicycle facilities on road (mid-block)

Section of <i>Cycling Aspects of Austroads Guides</i>					
Guide	Section	Reference source	Guide	Section	Reference source
Section 4.1: General					
	Section 4.8	Austrroads (2010b)			
Section 4.2: Traffic Management Considerations					
	Commentary 11	Austrroads (2014b)			
Section 4.3: Key Design Criteria and Considerations (also Section 7.5)					
	Section 4.8	Austrroads (2010b)			
Section 4.4: Provision for Cyclists on Roads					
	Section 4.8	Austrroads (2010b)		Sections 3.2, 3.3 and 3.4 Commentary 11	Austrroads (2014b)
Section 4.5: Types of Bicycle Lane Treatments					
	Section 4.8	Austrroads (2010b)			
Section 4.6: Finding Space for Bicycle Lane Treatments					
	Section 3.4	Austrroads (2014b)			
Section 4.7: Supplementary Road Treatments					
	Sections 4.8.7 and 4.8.12	Austrroads (2010b)			
Section 4.8: Ramps					
	Section 4.8.7	Austrroads (2010b)			
Section 4.9: Provision for Cyclists on Freeways					
	Section 3.4	Austrroads (2014b)		Commentary 5	Austrroads (2009e)
Section 4.10: Local Area Traffic Management Schemes					
	Sections 7.5.11 and 8.12.1	Austrroads (2008a)			

Notes:



Guide to Road Design (GRD)



Guide to Traffic Management (GTM)

4.2 Key Design Criteria and Considerations

Factors to be considered with respect to horizontal and vertical alignment, gradients, cross-section and clearances are provided in Sections 4.8.2 to 4.8.4 of GRD 3. Road alignments and gradients are almost always determined by motor vehicle requirements. Widths and clearances are therefore the important elements that relate to on-road facilities.

4.2.1 Road Geometry

The vertical and horizontal alignment standard adopted on roads to serve the needs of motor traffic will normally be satisfactory for bicycle riding provided the operational aspects of cycling are understood by road authorities, engineers, planners and designers.

4.2.2 Gradients

Whilst motor vehicles have little difficulty climbing most hills, bicycle riders prefer to avoid hills wherever possible. They normally select the flattest alternative route to minimise the amount of climbing. In climbing steep hills, experienced cyclists work the bicycle from side to side whilst the inexperienced tend to wobble. In situations where a steep gradient is unavoidable additional pavement width should be provided to allow for this operating characteristic.

Because excessive gradients on hills can be unpleasant to cyclists and act as a deterrent to bicycle riding, road planners and designers should strive to minimise gradients on all new works including those in new subdivisions. It may be possible to achieve flatter grades on important collector roads for little additional cost.

Further information regarding gradients for cyclists on paths can be found in GRD 6A.

4.2.3 Cross-section and Clearances

On roads carrying less than 3000 vehicles per day, bicycle riders and motor vehicles can generally share the road. However, where this volume is exceeded and where speeds are high, motor vehicles will constantly pass bicycle riders and hence the width of the left hand lane should be at least sufficient for cars and bicycles to travel side by side. This requirement applies equally along roads and at intersections.

Due to the side 'wind' force exerted on bicycle riders from heavy vehicles, roads should be designed to provide satisfactory clearances between the bicycle envelope and the vehicle. Table 4.2 lists the desirable clearances that should be provided to enhance cyclist safety. The cyclist envelope is shown in Figure 3.1. Similar clearances to cars should be provided in order that cyclists do not feel unduly threatened by general motor traffic. However, the inability to achieve these clearances should not preclude the provision of a facility having a lesser clearance unless a suitable alternative route or means of accommodating cyclists exists within the road reserve.

Table 4.2: Clearance to cyclist envelope from adjacent truck

Speed limit (km/h)	60	80	100	100+
Desirable clearance (m)	1.0	1.5	2.0	2.0+

Source: Austroads (2010b) Table 4.16.

In most instances, a range of treatment widths have been provided in this section. Whilst tables are provided to guide the choice of width, when choosing the actual lane or treatment widths for particular sites practitioners should carefully assess:

- parking conditions
- motor vehicle speed
- motor vehicle volume

- bicycle/parking lane width
- bicycle volume
- car lane width
- percentage of heavy vehicles
- alignment of road.

The demand for the adjoining motor traffic lanes is also an important issue in assessing the adequacy of bicycle lanes. Where a road is operating close to capacity and narrow bicycle lanes exist, there may be insufficient opportunities or it may be hazardous for cyclists to pass each other. Therefore, if a demand for passing within bicycle lanes is likely in peak hours a minimum bicycle lane width of 2.0 m should be provided along congested roads. Surface conditions and edge clearances to kerbs need to be considered in the assessment of the capacity of road lanes for bicycles.

While not a common problem, the capacity of bicycle lanes may need to be considered in certain locations, e.g. priority cycling routes providing access to capital cities. Information provided in Section 7.5 of this document and GRD 6A is also applicable to bicycle lanes on roads. Surface conditions and edge clearances to kerbs need to be considered in the assessment of the capacity of road lanes for bicycles.

Where the difference between bicycle and motor traffic speeds is less than 20 km/h, full integration may be acceptable, i.e. where bicycles and motor traffic share the road without any special provisions. Conversely, segregation is most desirable where the differences between bicycle and motor traffic speeds exceed 40 km/h.

On this basis, it is preferable that wide kerbside lane treatments are avoided where possible along roads with a speed limit in excess of 70 km/h, given the 85th percentile speed of cyclists under free flow conditions is in the order of 30 km/h. Similarly, where hills exist, the lower speed differential between motor and bicycle traffic for downhill travel, and the 'wobble' effect for uphill travel, are such that it may be appropriate to provide a bicycle lane treatment in the uphill direction only, where width constraints exist and there is no opportunity for the provision of a bicycle lane in the downhill direction.

4.3 Provision for Cyclists on Roads

4.3.1 General

Under the *Australian Road Rules* cyclists may move along roads in three areas defined in the rules as a bicycle lane, a marked lane or a shoulder. An example of a guide to the use of these facilities is provided in Figure 2.2. Cyclists may also ride in special-purpose lanes if permitted by the relevant jurisdiction, and are required to obey the relevant rules when using a bicycle lane, marked lane or shoulder.

4.3.2 Exclusive Bicycle Lanes

Exclusive bicycle lanes for cyclists (Section 4.8.7, GRD 3) should be viewed as part of a bicycle network providing the connectivity required to enable convenient and safer trips by bicycle. An exclusive bicycle lane is:

- a lane created by 'bicycle lane' signs and delineated by pavement markings (Figure 4.1)
- the preferred treatment for cyclists on roads without any form of physical separation
- generally located at the left side of a road.

Exclusive bicycle lanes should be provided on both sides of the road where possible so that use is in the same direction as motor vehicle traffic.

Figure 4.1: An example of an exclusive bicycle lane



Note: Green coloured surface treatments should only be used to increase driver and cyclist awareness of an exclusive bicycle lane, and to discourage drivers from encroaching into an exclusive bicycle lane. The treatment should be used sparingly to maintain its effectiveness. Refer to Section 9.4 of this document and Section 6.6 of GTM 10. Source: Austroads (2010b) Figure 4.24.

Motor traffic is generally prohibited by traffic regulations from travelling in the bicycle lane except to access property or to turn at intersections. Similarly, parking in the lane may be prohibited either full-time or otherwise during the designated periods of operation of the lane (refer to local road rules).

Exclusive bicycle lanes are often necessary in order to provide a safer environment for cyclists, a satisfactory level of service, and positive connectivity of a cycling route. The provision of a painted line between the motor vehicle lane and the bicycle lane together with bicycle pavement symbols at frequent intervals has a number of advantages as it (Commentary 11, GTM 5):

- clearly defines the road space provided for use by each mode
- results in motor vehicles generally not blocking the progress of cyclists where traffic queues exist
- provides lateral separation and improved safety when motor vehicles in the adjacent lane are moving
- creates awareness in the minds of motorists that a cyclist may be present (at times when few cyclists are using the lane).

Exclusive bicycle lanes:

- may combine with particular characteristics of the road to form different types of treatment (e.g. in conjunction with parallel or angle parking); refer to Section 4.4
- may sometimes be installed as part-time facilities by the removal of car parking along arterial roads during certain times (e.g. peak periods); however, an adequate level of parking enforcement is required for the treatment to be effective for cyclists
- can be often very difficult or impracticable to achieve for existing road conditions. However, there are a range of other forms of lanes and treatments that may be provided to improve the quality of a cyclist's riding experience on the road
- may be appropriate or highly desirable (depending on site conditions) where
 - bicycle traffic is concentrated (e.g. near schools or along major routes near city or town centres)
 - an existing or future significant demand for bicycle travel can be demonstrated (e.g. where traffic volumes and speeds deter cyclists from using an otherwise favourable route)
 - they are needed to provide continuity within a bicycle route network
 - a road is carrying or is likely to carry more than 3000 vehicles per day and/or a significant percentage of heavy vehicles.

The width adopted for exclusive bicycle lanes will vary depending on the:

- number of cyclists
- speed of motor traffic
- volume of large vehicles
- ability to make space available
- needs of other road user groups
- physical constraints and budgetary constraints.

Designers should consider these factors when assessing the bicycle lane width required at particular sites. However, Table 4.3 shows the minimum bicycle lane widths for roads posted at various speeds in urban areas. These dimensions should also be applied to rural roads where a bicycle lane or satisfactory sealed shoulder is considered necessary (Section 4.3.4).

Table 4.3: Exclusive bicycle lane dimensions in urban areas

Road posted speed limit (km/h) ⁽¹⁾	Lane width ⁽²⁾⁽³⁾ (m)		
	60	80	100
Desirable	1.5	2.0	2.5
Acceptable range	1.2–2.5	1.8–2.7	2.0–3.0

1 The posted or general speed limit is used, unless 85th percentile speed is known and is significantly higher.

2 Interpolation for different speed limits is acceptable.

3 The width of the lane is normally measured from the face of the adjacent left-hand kerb. The width of road gutters/channels (comprising a different surface medium) should be less than 0.4 m where minimum dimensions are used. The figures in the table presume that surface conditions are to be of the highest standard. Where there are poor surface conditions (see GRD 6A, Appendix B) over a section of road adjacent to the gutter, then the width of the exclusive bicycle lane should be measured from the outside edge of that section.

Source: Austroads (2010b) Table 4.17.

With reference to Note 3 to Table 4.3, it is desirable that the channel should not be included as part of the exclusive bicycle lane width, particularly where there are potential safety concerns, including:

- edge drop-off between the pavement and channel surfaces, particularly when open graded friction course (OGFC) is used
- steep and abrupt change in crossfall slopes to match resurfaced roads to the lips of channels as these slopes can adversely affect the stability of cyclists
- hazards in and adjacent to the kerb and channel such as the surface condition of the channel and drainage pit entrances
- the likelihood of the bicycle pedals striking the kerb.

Given the difficulty in many situations to find adequate road space to install an exclusive bicycle lane an assessment should be undertaken to determine if the kerb and channel can or should be incorporated into the bicycle lane width.

4.3.3 Wide Kerbside Lanes

A wide kerbside lane is a normal marked lane on the left side of the carriageway (of either a two-lane two-way road or multi-lane road) of sufficient width to allow cyclists to travel beside the main traffic stream and to permit motorists to overtake cyclists without having to effectively change lanes (Figure 4.2). This sharing of lanes is generally appropriate in speed zones of 70 km/h or less. The sharing of lanes cannot be legally performed (and hence facilitated) in all states.

Wide kerbside lanes are appropriate on all major traffic routes and collector roads, whether divided or undivided, on sections of road where parking is either minimal or prohibited during peak periods.

Figure 4.2: Wide kerbside lane



Source: Austroads (2010b) Figure 4.29.

A guide to the width of wide kerbside lanes is provided in Table 4.4.

Table 4.4: Wide kerbside lane dimensions

Road posted speed limit ⁽¹⁾ (km/h)	Lane width ⁽²⁾⁽³⁾ (m)	
	60 km/h	80 km/h
Desirable minimum	4.2	4.5
Acceptable range	3.7–4.5	4.3–5.0

1 The posted or general speed limit is used, unless 85th percentile speed is known and is significantly higher.

2 Interpolation for different speed limits is acceptable.

3 The width of the lane is normally measured from the face of the adjacent left-hand kerb. The width of road gutters/channels (comprising a different surface medium) should be less than 0.4 m where minimum dimensions are used. The figures in the table presume that surface conditions are to be of the highest standard. Where there are poor surface conditions over a section of road adjacent to the gutter, then the width of the wide kerbside lane should be measured from the outside edge of that section.

Source: Austroads (2010b) Table 4.20.

Table 4.4 indicates the desirable width and acceptable range of width for wide kerbside lanes in 60 km/h and 80 km/h speed zones (unless noted otherwise). Whilst the table suggests that a 4.5 m lane width is desirable in 80 km/h zones designers should understand that it is always preferable to provide a marked exclusive bicycle lane instead of a wide kerbside lane, particularly in higher speed zones (i.e. 70 km/h and 80 km/h). Where space cannot be made available for an exclusive bicycle lane a wide kerbside lane can offer benefit to cyclists in terms of safety and comfort.

Other considerations when using wide kerbside lanes are:

- Where kerbside parking is significant in the off-peak period, the wide kerbside lane should be at least 4.0 m wide so that the lane will function satisfactorily as a bicycle/parking lane during these periods even though special pavement marking is not provided for guidance.
- Exclusive bicycle lanes are preferred where a road has regular curves or where an unusually high number of heavy vehicles use the road.
- For roads with a posted speed limit of 80 km/h, wide kerbside lanes are only suitable where the demand for parking is low.

4.3.4 Sealed Shoulders

Where a road is un-kerbed and provision for cyclists is required, a smooth sealed shoulder is the preferred treatment. Although warrants do not exist specifically for the provision of sealed shoulders for cyclists there are many instances on rural roads where the sealing of shoulders is justified specifically to make roads safer for cycling.

Table 4.5 of GRD 3 provides some guidance as to the appropriate standard to be provided for cyclists. This table relates shoulder width to traffic volume and cyclists' requirements are referred to only in note 2 to the table, which states:

Where significant numbers of cyclists use the roadway, consideration should be given to fully sealing the shoulders. Suggest use of a maximum size 10 mm seal within a 20 km radius of towns.

Widths required for sealed shoulders for bicycle usage are generally the same as those required for exclusive bicycle lanes, as shown in Table 4.3. Although this table relates the width to speed, the widths are not inconsistent with Table 4.5 in GRD 3. Provision for cyclists should be maintained through intersections, past driveways, and at those locations where the road is kerbed along lengths of road otherwise treated with sealed shoulders. Where a chip seal is used to seal the shoulders, consideration should be given to the use of a maximum size 10 mm stone to provide a smoother and less abrasive riding surface, as a larger size stone can cause concern for cyclists.

4.3.5 Bus/Bicycle Lanes

Whilst it is desirable that bicycles are accommodated in a separate bicycle lane, examples exist where bicycles have successfully shared in the use of bus lanes. In most circumstances cyclists may be permitted to use bus lanes when they are located next to the kerb on arterial or local roads. Considerations for provision of bicycles within bus lanes should be based on:

- the number of cyclists
- frequency of bus services
- the number of bus stops
- time required to set down and pick up passengers.

Generally, buses will overtake cyclists between bus stops and cyclists will catch up and overtake buses at bus stops. This process can lead to 'leap-frogging' along the bus lane.

The key to managing the impact of this process on the level of service to buses and cyclists is to provide a bus lane that is wide enough to accommodate these movements. A guide to the width is provided in Table 4.5. Alternatively, it may be possible to provide a separate on-road bicycle lane or off-road bicycle path adjacent to the bus lane and at bus stops.

Table 4.5: Width of kerbside bus lanes

Speed zone (km/h)	Width of bus lane (m)			Comment
	60	70	80	
Minimum width of bus lane that can be shared with cyclists	3.7	4.0	4.3	Bus lanes of this width are considered wide kerbside lanes and allow cyclists and buses to share the bus lane. Bus lanes of this width may be acceptable for routes that carry between 50 and 100 cyclists or where bus headways are between 15 and 30 minutes in the peak hour.
Minimum width of separated on-road bicycle lane	1.2	1.5	1.8	It is considered desirable to provide separated on-road bicycle lanes adjacent to bus lanes on routes that carry more than 100 cyclists and where bus headways are 15 minutes or less in the peak hour.
Minimum width of bus lane and separated on-road bicycle lane	4.2	4.6	5.1	This is the minimum width of the bus lane plus the minimum width of a separated on-road bicycle lane to provide the minimum separation between cyclists and buses.

Source: *Guide to Road Design* (2010b) Table 4.22.

4.3.6 Advisory Treatments

Advisory treatments are used to indicate or advise road users of the potential presence of cyclists and of the location where cyclists may be expected to ride on a road. They use pavement markings, warning signs or guide signs, and as such have no regulatory function. The purpose of these treatments is usually to define a bicycle route rather than a type of facility to which specific road rules apply. The form of the treatment is a matter for local jurisdictions.

4.4 Types of Bicycle Lane Treatments

This section briefly describes the various types of bicycle lane treatments and provides guidance on use and the width of the treatments.

4.4.1 Bicycle/Car Parking Lanes

Bicycle/car parking lanes are most appropriate where the street is wide, there is a demand for parking (and where road space and capacity requirements allow parking throughout the day). It is most important to provide a width that is adequate to accommodate parked vehicles, operating space for cyclists and adequate clearance to accommodate the opened door of parked vehicles.

Further discussion is provided in Section 4.8.10 of GRD 3. Bicycle/car parking lanes may be provided in conjunction with parallel parking or angle parking.

With parallel parking

Table 4.6 provides guidance on widths of bicycle/car parking lanes with parallel parking and the associated layout is shown Figure 4.3. Also, it should be noted that:

- 4.5 m is the acceptable maximum width as a greater width may result in moving cars attempting to utilise the bicycle lane. It provides acceptable clearances in cases where parking turnover is significant or traffic speeds are in excess of 60 km/h but no greater than 80 km/h
- 4.2 m is the desirable width where speeds are about 60 km/h as it provides comfortable clearance to parked cars
- 4.0 m is the acceptable minimum width where traffic speeds are about 60 km/h as it enables a cyclist to travel adjacent to parked and moving cars at a reasonable speed with minimum clearances.

Table 4.6: Bicycle/car parking lane dimensions (parallel parking)

Road posted speed limit (km/h)	Overall facility width (m)	
	60 km/h	80 km/h
Desirable minimum	4.0	4.5
Acceptable range	3.7–4.5	4.0–4.7

Source: Austroads (2010b) Table 4.18.

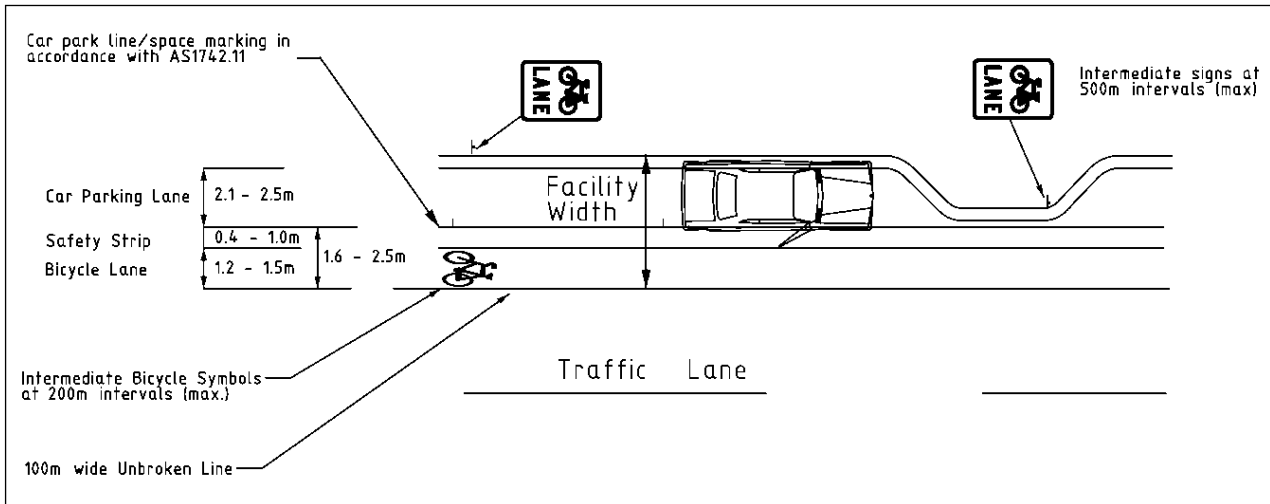
Figure 4.3: Typical bicycle/car parking lanes layout (parallel parking)

Source: Austroads (2010b) Figure 4.27.

With angle parking

This treatment is illustrated in Figure 4.4. The entry and exit conditions of angle parking require that a high level of protection is provided to cyclists. The provision of marked bicycle lanes adjacent to angle parking is therefore most desirable. Whilst an opening car door does not pose a threat to cyclists in the case of angle parking, cyclists have to be alert to vehicles reversing (regardless of orientation) into their path. It is most important in cases where parallel parking is being converted to angle parking that the needs of cyclists are given adequate consideration.

This treatment is appropriate only where the posted or general speed limit is less than or equal to 70 km/h. The provision of kerbed projections or other treatments including channelisation is recognised as extremely important. Treatments should be constructed immediately to the left of the bicycle lanes at the start of this type of lane facility and at regular intervals to limit the incidence of vehicles travelling over, or to the left of, the bicycle lane.

Figure 4.4: Typical bicycle/car parking lanes layout (angle parking)

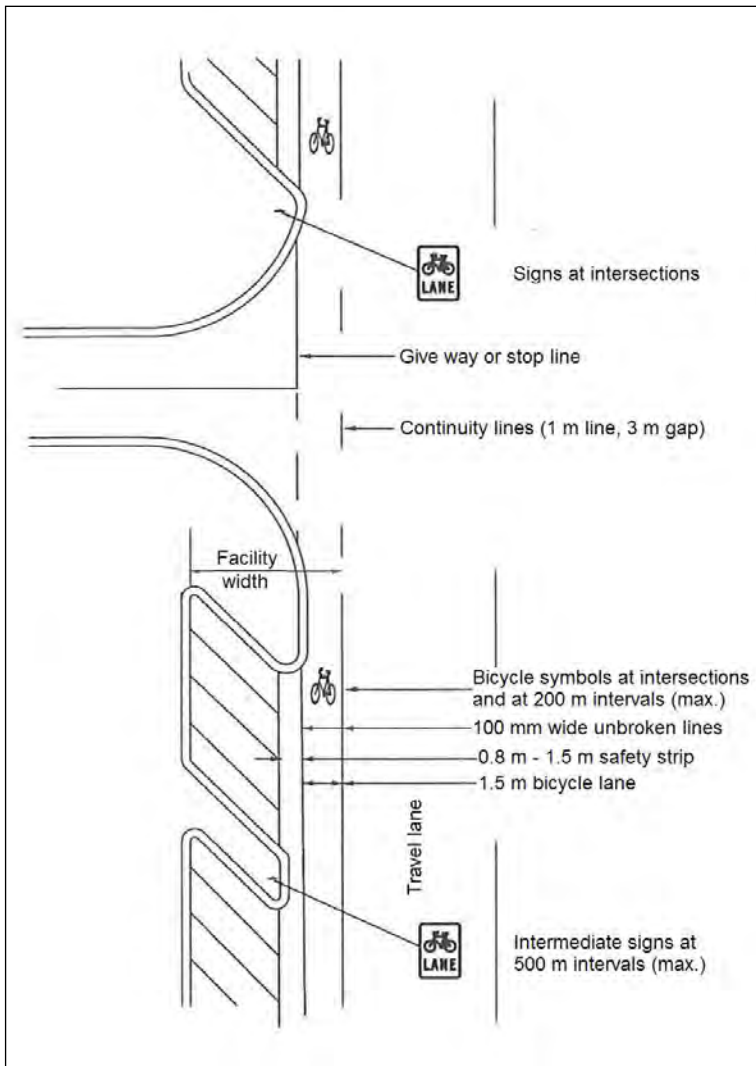

Source: Austroads (2010b) Figure 4.28.

Table 4.7 is a guide to the overall width required to provide a bicycle/car parking lane with angle parking.

Table 4.7: Bicycle/car parking lane dimensions (angle parking)

Parking angle (degrees)	Overall facility width (m)		
	45	60	70
Desirable	7.3	7.6	8.0
Acceptable range	7.1–7.8	7.4–8.1	7.8–8.5

Notes:

- Measured from kerb face to the marked line defining the left edge of the traffic lane. These dimensions assume parked cars can overhang the kerb. An additional 0.6 m should be added where overhanging of the kerb is not possible (i.e. parking to a wall).
- This facility should be constructed only where the speed limit is 70 km/h or less. The value of 90 km/h in the right-hand column of Table 4.19 in GRD 3 is erroneous.

Source: Austroads (2010b) Table 4.19.

4.4.2 Contra-flow Bicycle Lanes

A contra-flow bicycle lane is an exclusive bicycle lane that enables cyclists to travel in both directions in a one-way street (Figure 4.5). Contra-flow bicycle lanes:

- should be considered an acceptable treatment in urban environments where sufficient road widths exist to provide a safer treatment
- should have a width appropriate to the situation (refer to Table 4.3); absolute minimum = 1.5 m; desirable = 1.8 m
- should be physically separated from motor traffic where used in speed zones ≥ 60 km/h by a raised traffic island (preferable) or a safety strip that is desirably 1 m wide (0.6 m minimum)
- without physical separation from the adjacent traffic lane (i.e. raised island or safety strip) are generally appropriate only in speed zones up to 50 km/h
- may be placed between parked cars and the kerb where bicycle access is important. Although this is not ideal, it may be satisfactory where cyclists do not need to frequently leave or join the facility over its length and cycling speeds are low. In such cases it is imperative to provide a 1.0 m separator (preferably a raised island) to allow for vehicle overhang or opening car doors.

Figure 4.5: Contra-flow bicycle lane example



Source: Austroads (2010b) Figure 4.23.

4.4.3 Separated Bicycle Lanes

The provision of a separated bicycle lane aims to improve the safety for cyclists by providing (physical) separation from other motor traffic whilst maintaining directness of travel and priority at intersections. Separated bicycle lanes are also referred to as:

- kerb separated bicycle lanes
- protected bicycle lanes.

A separated bicycle lane:

- is usually considered where a substantial length of road is being widened or duplicated and where there are few driveways and intersections
- generally provides a higher level of service for cyclists and has been shown to promote increased patronage on cycling routes
- is an option to be considered where a full width off-road path with suitably high levels of directness and priority for cyclists at intersections cannot be achieved within the existing road reservation.

Kerb separated bicycle lanes

Figure 4.6 illustrates a kerb separated bicycle lane and Figure 4.7 shows an example. Table 4.8 summarises aspects to be considered in the design of this type of lane.

Figure 4.6: Location and typical cross-section of kerb separated bicycle lane

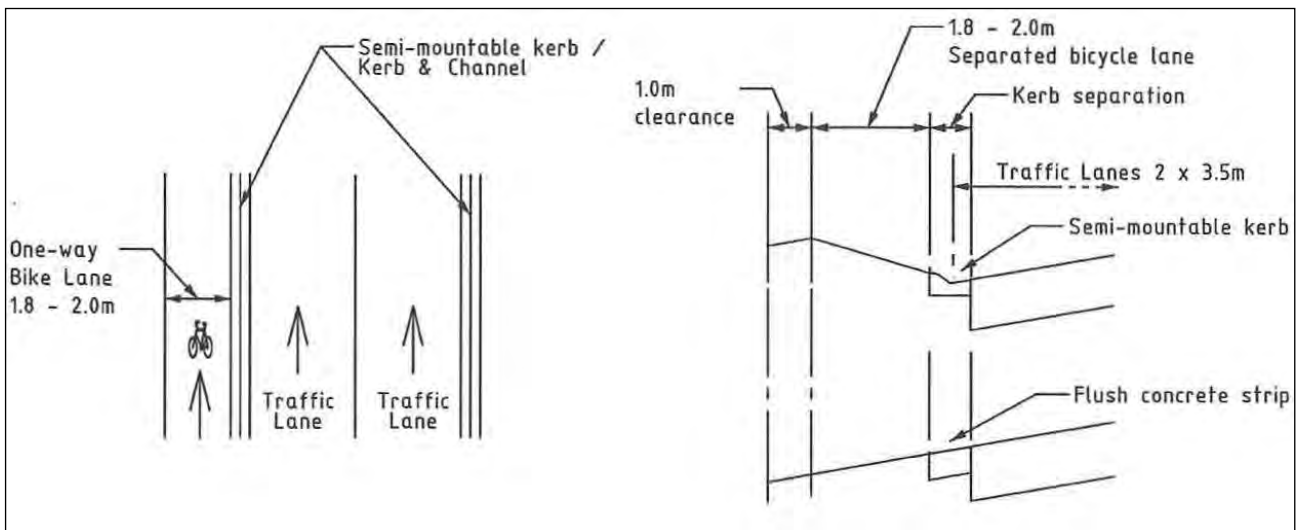

Note: A one-way crossfall should be applied where a flush concrete strip is used so that drainage does not accumulate on the bicycle path.
 Source: Austroads (2010b) Figure 4.20.

Figure 4.7: Kerb separated bicycle lane



Source: Austroads (2010b) Figure 4.21.

Table 4.8: Considerations in the design of kerb separated bicycle lanes

Aspect	Consideration
Operation	Are designed to operate one-way, for bicycle use only and are required on both sides of the road.
Separator	The treatment is raised above the traffic lanes and is usually situated alongside semi-mountable kerb and channel, unless a flush treatment is required for drainage considerations in which case a 600 mm wide flush kerb or edge strip may be used. The separation may need to be increased by 1.0 m from the back of the kerb to provide clearance from car doors where kerbside parking is likely to occur.
Transition	The treatment should rejoin the road as an exclusive bicycle lane prior to major intersections to provide a conventional level of directness and priority. This should be accommodated by means of a ramp having a grade no steeper than 10%.
Obstructions	Consider obstructions such as street lighting and other utility poles, signs, road safety barriers and any other roadside furniture.
Surface	Provide a smooth riding surface. Wherever practicable locate drainage pit lids outside of the lane; otherwise construct with (concrete in-filled) cast iron covers to ensure a flush finish.
Pedestrians	The lane is widened to operate as a separated bicycle/pedestrian path or be accompanied by a clearly marked separate footpath if pedestrian demands would otherwise result in the mixing of cyclists and pedestrians in the space immediately adjacent to the through traffic lanes.
Bus stops	Consider the treatment of both on-road and indented bus stops to provide a safer facility for both cyclists and bus patrons. The separated bicycle lane can be taken around the back of the bus stop or transitioned back onto the road pavement as an exclusive bicycle lane.
Delineation	Appropriate signs and pavement markings should be installed to encourage cyclists to use the facility and to discourage pedestrian use.

Source: Austroads (2010b) summarised from Section 4.8.5.

Separated protected bicycle lanes

A separated protected bicycle lane (Figure 4.8) is a particular form of separated bicycle lane. This treatment:

- may be applied in urban areas where parking is prevalent
- is characterised by a raised separation strip to physically prevent vehicular access to the bicycle lane and provide clearance for the opening of car doors.

The raised separator generally requires breaks in the kerb to maintain the free drainage of the road (in a retrofit situation) or otherwise a specific drainage system needs to be installed. Frequent maintenance of these bicycle lanes is required to ensure that they do not accumulate debris and litter that would normally be collected by a street sweeper in routine road maintenance. This is important because cyclists using this type of facility are unable to readily deviate around debris (as they could when using a conventional bicycle lane) such as glass, stones, and other objects that could puncture tyres or cause instability of bicycles.

Figure 4.8: Typical cross-section of a separated protected bicycle lane

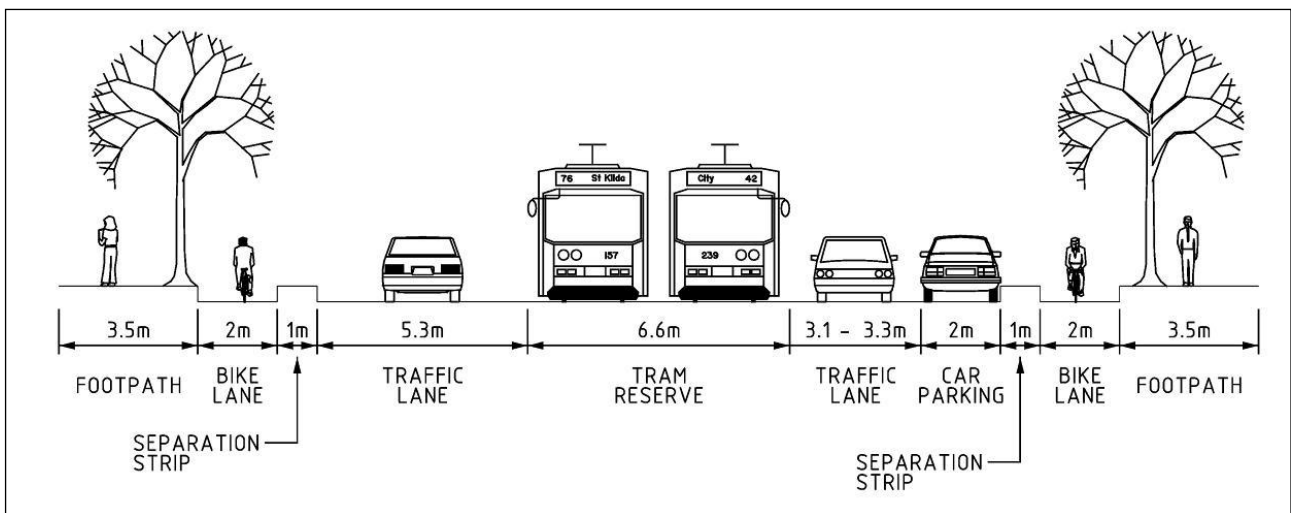

Note: Example is a typical cross-section constructed in Melbourne with a bicycle lane width of 2 m. Source: Austroads (2010b) Figure 4.22.

4.4.4 'Peak Period' Bicycle Lanes

'Peak period' bicycle lanes (Figure 4.9) are common on roads designated with clearways. The restriction of parking during peak traffic periods usually coincides with peak cyclist numbers. On roads where the adjoining land use is predominantly residential, the installation of bicycle lanes during peak periods can be a compromise between the adjoining residents' desire for on-street parking and cyclists' need for designated road space. The timing of the parking restrictions to coincide with local school opening and closure times has the additional advantage of providing a separate cycling facility for school children (GRD 3). The treatment may also be appropriate for sections of road that have abutting commercial development.

Peak period bicycle lanes should only be used when no other option is possible. Often the carriageway layout is such that during off-peak periods cyclists have to contend with stressful and potentially hazardous conditions when cars are parked at the kerbside. It is important in the design of the bicycle lane that conditions for cyclists are assessed for different periods of the day, and that the prohibition of parking associated with the lane is effectively enforced.

Figure 4.9: Peak period bicycle lane (i.e. during and outside clearway times)

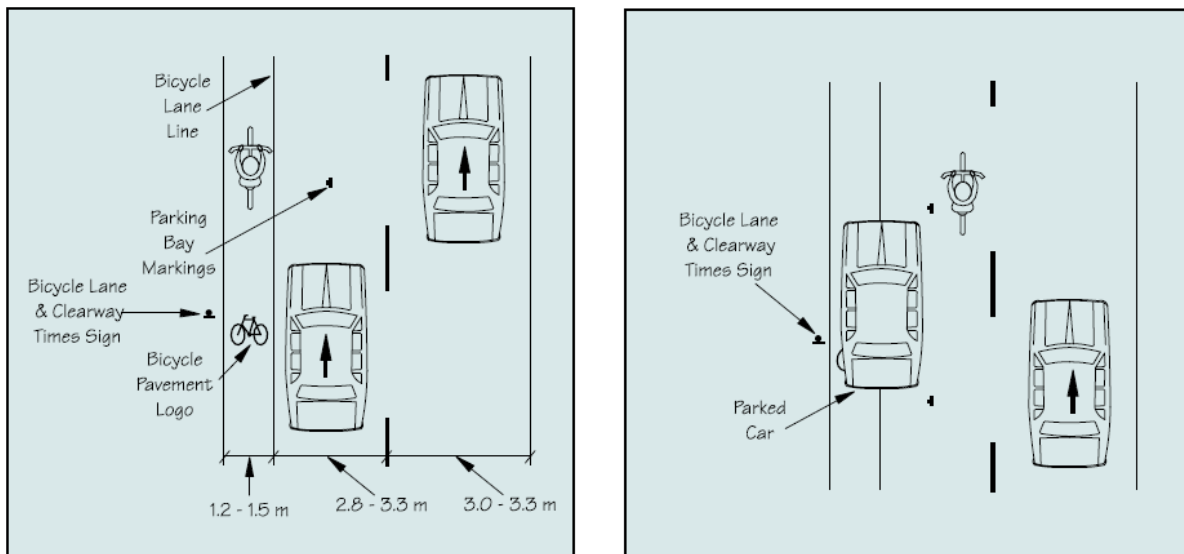

Source: Austroads (2010b) Figure 4.26 and VicRoads (1999).

4.4.5 Protected Two-way Lanes

A protected two-way bicycle lane is an exclusive bicycle lane treatment installed on one side of a road carriageway. The treatment utilises the existing road surface and is physically separated from adjacent two-way traffic lanes and may be appropriate where:

- origins and destinations are on the same side of the road and as such road crossings can be avoided
- there is no choice other than for a treatment within the road reserve in a length generally consisting of paths and where the need for road crossings by cyclists can be avoided
- relatively few driveway crossings exist, particularly where the route is used by children
- parking demand is low in the area of the treatment, and as a consequence would be removed
- the road is wide such that parking is retained adjacent to (but outside of) the bicycle path area. In this instance the facility is regarded as appropriate only where the parking is long-term.

In general, the regulations applying to exclusive bicycle paths, in relation to travelling or stopping in protected lanes, by motor traffic, pedestrians and others, would also be applicable.

4.5 Finding Space for Bicycle Lane Treatments

A number of techniques can be used to obtain space in road reserves for the provision of cyclist facilities. These include:

- rearrangement of space by:
 - adjustment of existing carriageway (narrowing adjacent traffic lanes)
 - upgrading service roads
 - sealing road shoulders
- trading space through:
 - indented car parking
 - restricting car parking
 - road widening at the verge
 - road widening at the median
 - removing a traffic lane
 - closing a road
- alternative space such as:
 - an alternative off-road route.

4.6 Supplementary Road Treatments

4.6.1 Curves and Turns

On the inside of small radii horizontal curves, tight turns and other local area traffic management facilities, cyclists can often be at danger of rear-end/side-swipe collisions from motor vehicles that are travelling too close. The following forms of protection provide safety benefits to cyclists at these locations, and should be considered as part of the application of the various bicycle lane facilities discussed in this guide.

Effective forms of protection include (GRD 3, Section 4.8.12):

- pavement bar island
- raised traffic islands
- fully mountable kerbing at the left side of the carriageway (to the direction of travel of cyclists), to permit access to the footpath at any point along the length of kerb
- closely spaced (e.g. 3 m intervals) raised pavement markers applied outside of bicycle lanes
- short lengths of off-road bicycle lanes to bypass pinch points in the cross-section.

A road authority may consider other forms of protection such as enhanced lane markings to improve delineation and separation.

Where treatments take cyclists off the road, care needs to be exercised to ensure that cyclists travelling at speed are not directed out into the traffic stream at the exit point. These treatments should be self-cleaning to avoid the accumulation of debris; otherwise a comprehensive maintenance program will be required.

Designers should also ensure that the safety and other needs of pedestrians are provided for, wherever off-road cycling treatments are proposed.

4.6.2 Lane Channelisation

Where there is a need to provide additional protection to or reinforcement of exclusive bicycle lanes, channelisation treatments can be employed. These treatments assist drivers to identify the space for cyclists and help to minimise vehicle ingress into bicycle lanes. Channelisation treatments can consist of:

- continuity lines
- kerbed projections which also help to guide the path of cyclists to the area of the bicycle lane
- rumble (tactile) edge lines
- low profile rubber kerbing.

4.7 Ramps

Ramps linking a road carriageway and a path located in the area of the roadside verge may be required in association with protection at curves, narrowing at right-turn lanes and path treatments adjacent to roads.

The exit ramp from the road should be oriented to enable the cyclist to leave the road at a speed appropriate to the abutting development and the level of pedestrian usage of the path. The ramp for re-entering the traffic stream should be placed at an angle that enables cyclists to conveniently view traffic approaching in the left-hand lane. Consideration should also be given to providing a kerb extension to shelter the reintroduction of an exclusive bicycle lane.

The gradient of ramps to and from raised path sections should be constructed to avoid an abrupt change of grade (in excess of 5%) and in general should not be steeper than 15:1 where high bicycle speeds are likely. Figure 4.10 provides guidance to assist designers to design ramps for low and high-speed movements.

Figure 4.10: Low and high-speed exit and entry ramps

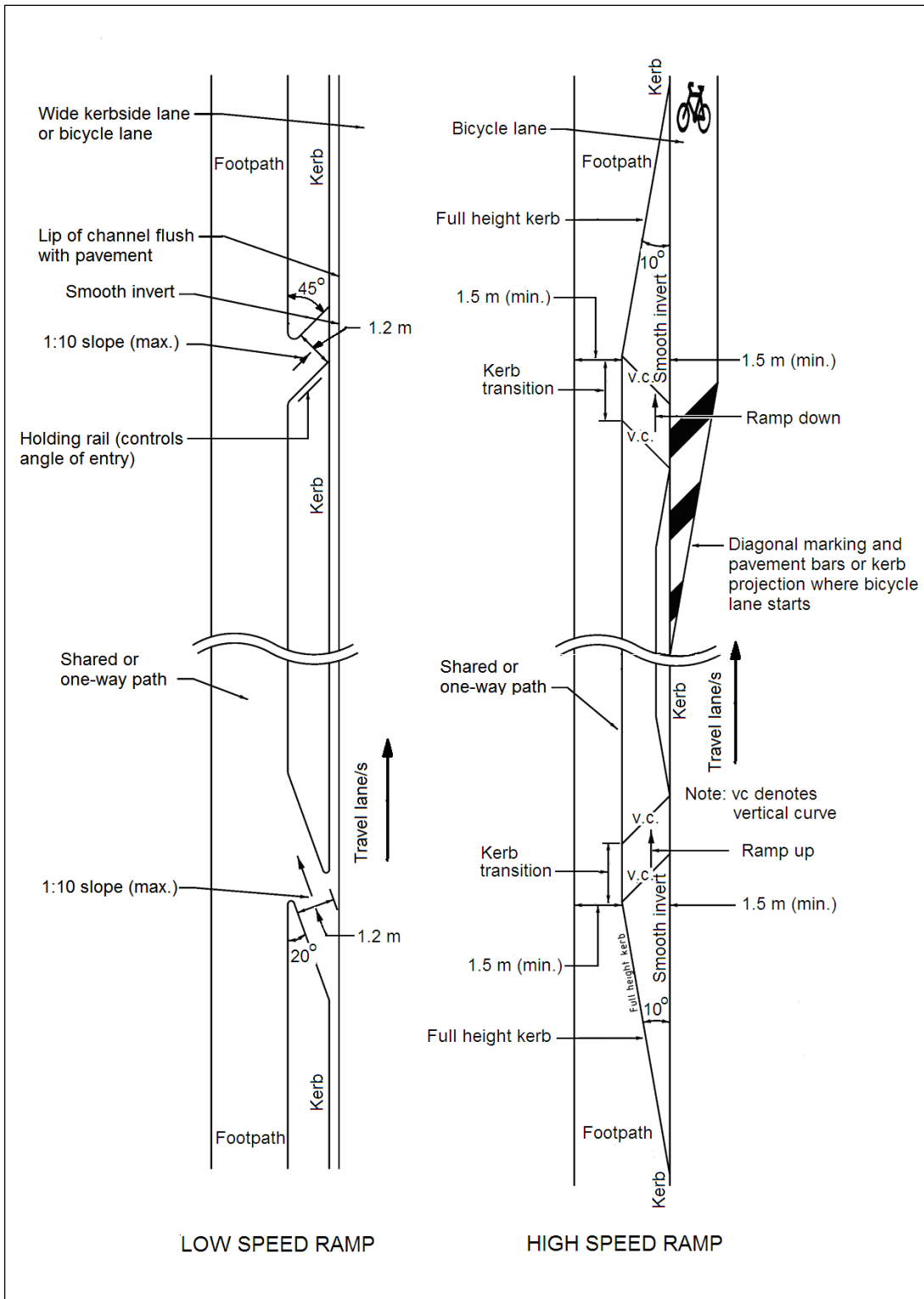

Source: Austroads (2010b) Figure 4.25.

4.8 Provision for Cycling on Freeways

4.8.1 General

The main issue that should be addressed in deciding whether cyclists may use freeways is road safety. The policy with respect to cyclists using freeways varies between jurisdictions. Where cyclists are permitted to use a freeway it is important that they are provided with information, guidance and road conditions which enable them to use it safely. It is inappropriate for cyclists to use the normal traffic lanes of freeways and safer use of these facilities by cyclists is predicated on providing:

- smooth, debris-free shoulders of adequate width
- safe treatments at interchanges
- an efficient and safer route within the corridor if cyclists are not permitted to use the freeway (e.g. a high-speed exclusive bicycle path, a shared path or an alternative road route).

Because rural freeways usually have relatively low volumes of traffic leaving and entering at interchange ramps cyclists should normally be allowed to use rural freeways, particularly those having sealed shoulders, provided that information and guidance is given to guide them safely across exit and entry ramps.

The use of urban freeways by cyclists is a matter to be determined by the relevant jurisdiction which may decide to deny cyclists' access to specific freeways because of the difficulties and hazards which would confront them in high-volume, high-speed traffic environments. A number of factors should be considered when assessing the suitability of a freeway and its interchanges for use by cyclists, as summarised in Table 4.9.

Table 4.9: Cyclist use of freeways – factors to consider

Unreasonably hazardous locations	Suitability for use
<ul style="list-style-type: none"> ▪ Shoulders which are too narrow. ▪ Off-ramps and on-ramps which carry very heavy volumes of high-speed traffic throughout the day and night. ▪ Sections of freeway where the shoulders are used as bus lanes to provide a relatively high-speed express bus service. ▪ High bridges where prevailing crosswinds and turbulence from large motor vehicles can destabilise cyclists. ▪ Weaving areas between entry ramps and exit ramps. ▪ Places where vehicles stop in the emergency stopping lane (i.e. shoulder). 	<ul style="list-style-type: none"> ▪ The freeway should provide a safer and more convenient route than alternative non-freeway routes. ▪ Potential for use of the freeway by children should be low. ▪ Sealed outer shoulders are essential on freeways which carry heavy volumes of motor vehicles and significant numbers of cyclists. For 100 km/h a 3.0 m width is desirable but a minimum width of 2.0 m may be used. For 80 km/h the corresponding widths are 2.0 m and 1.5 m. ▪ Adequate gaps should be available in ramp traffic to allow crossing by cyclists; otherwise provide an alternative route through or around the interchange (refer to Section 5.6 of this document and Section 14 of GRD 4C). ▪ All ramps should have an outer shoulder at least 1.2 m wide, preferably sealed. ▪ Ramps exiting and entering the freeway from the right-hand lane are likely to be unsuitable for cyclists as they have to cross two lanes of high-speed traffic to access them. Alternative routes have to be examined. ▪ Sight distance in accordance with a pedestrian crossing the road: crossing sight distance (CSD; refer to GRD 4A) should be provided at the location where cyclists are directed to cross freeway ramps. ▪ Where very high traffic volumes or difficult geometry would cause serious safety hazards an alternative route or an off-carriageway cycling path may need to be provided.

Source: Austroads (2009e) summarised from Commentary 5.

The following guidelines should be considered when planning bicycle lanes on freeways:

- Cyclists may be permitted on rural freeways/motorways subject to risk assessments where:
 - wide, sealed shoulders of freeways provide cyclists adequate clearance from vehicles in the adjacent lane; the shoulder may be marked as a designated bicycle lane
 - there is a good quality riding surface
 - conflict between motor vehicles and bicycles at entry and exit ramps is minimal or is able to be managed through traffic control or design measures (refer to Section 5.6, GTM 6 for further information).
- The crossing of interchange entry and exit ramps is an aspect of cyclists' use of freeways/motorways that requires careful consideration. In rural areas sufficient gaps in ramp traffic will usually be available. Where volumes are relatively high a traffic assessment based on gap acceptance analysis may be necessary (refer to Ove Arup & Partners 1989). Treatments for ramps are described in Section 5.6.
- Road authority policy often bans cyclists from urban freeways.

4.9 Local Area Traffic Management Schemes

An underlying principle of LATM is that conditions should be made better for pedestrians and cyclists, by virtue of the intentions of LATM (particularly speed reduction) (Yeates 2000a, b). The consequences of poorly designed LATM schemes are more likely to impact on cyclists than pedestrians.

Factors to consider in regard to cyclists' use of roads that have LATM treatments are provided in Table 4.10. The content of this table is a summary of Section 8.12 of GTM 8. Other considerations are discussed in Section 2.9 of this document. Practitioners should refer to these sections for further guidance on catering for cyclists in local area traffic management schemes.

Table 4.10: Factors to consider for cycling in regards to LATM schemes

Aspect	Consideration
Principles	<ul style="list-style-type: none"> ▪ Cyclist needs should be an integral part of the LATM planning and design process rather than treated as a supplementary or post-design check. ▪ Unless speeds are quite low (say < 30–40 km/h) some form of separation for cyclists may be desirable (at least on the designated bicycle network). ▪ Separation is more critical at intersections and at devices that deflect the travel path (e.g. slow points) than at mid-block locations. Mid-block bicycle lanes should be carried through these more critical locations. ▪ On-road lanes are preferred over off-road paths for cyclists in local areas, especially where there is direct access to abutting development as cyclists entering or crossing roads, especially the young, are at increased risk. ▪ Ensure that LATM treatments that narrow the road carriageway width do not create safety problems for cyclists. ▪ Lane widths should either be wide enough to allow the safe passage of a cyclist and a vehicle side by side (3.7 m or more) or narrow enough to permit the passage of a vehicle or bicycle only (3.0 m or less). Widths in between these two extremes create squeeze points and result in conflicts. For a narrow lane width, provide an off-road option for young cyclists.
Design considerations	<p>There are three design issues that the treatment selection and design of LATM should take into account:</p> <ul style="list-style-type: none"> ▪ bicycle/vehicle conflict ▪ bicycle/pedestrian conflict ▪ cyclist service and comfort. <p>When adapting the traffic environment, keep in mind:</p> <ul style="list-style-type: none"> ▪ the dynamic characteristics of the bicycle and rider, which may vary widely according to age, bike type, experience, skill, etc. ▪ the seven broad categories of cyclists and their very specific needs, including primary school children, secondary school children, recreational cyclists, commuter cyclists, utility cyclists, touring cyclists and sports cyclists in training ▪ the sometimes aggressive, and often inconsiderate, attitude of drivers towards cyclists ▪ the youth and inexperience of many local street cyclists, who are nevertheless a legitimate part of the traffic system.

Aspect	Consideration
General requirements	<p>The following aspects of good LATM design and maintenance are especially important for cyclists:</p> <ul style="list-style-type: none"> ▪ avoid placing speed control devices in isolation ▪ position devices sufficiently close together to deter unnecessary acceleration and braking ▪ provide bicycle bypasses of devices <ul style="list-style-type: none"> – where closely spaced devices could detract from the attractiveness of the route for cyclists – where there is a significant difference in the speed of vehicular and bicycle traffic – where it is desirable to separate cyclists from other traffic – anywhere cycling needs to be encouraged ▪ provide clear signs and visibility ▪ provide adequate street lighting ▪ aim for a speed environment that is sympathetic to cyclists as well as other road users.
Route continuity	<ul style="list-style-type: none"> ▪ Actively improve bicycle route connectivity and continuity through appropriate LATM design. ▪ Provide for cyclists to pass through street closures and other treatments that block some or all motorised traffic movements. ▪ Where bicycle routes cross roads ensure that islands and refuges are wide enough to shelter bicycles (i.e. refuge width 3.0 m desirable, 2.0 m desirable minimum and 1.8 m minimum) and provide adequate storage where cyclist crossing volume is high.
Vehicle speeds	<ul style="list-style-type: none"> ▪ The most important contribution to pedestrian and cyclist safety and amenity in local streets comes from effective reduction in vehicle speeds. Aim at speeds below 40 km/h rather than above 50 km/h and a consistently low speed along the route.
Surfaces	<ul style="list-style-type: none"> ▪ Ensure surfaces for cyclists are smooth and free of irregularities that would adversely affect stability of bicycles that have narrow tyres. ▪ Maintain areas where debris may accumulate.
Squeeze points	<ul style="list-style-type: none"> ▪ Avoid points where cyclists would be squeezed by motorists. Either separate cyclists from motor vehicles or scale down the roadway so that sharing space is not possible.
Vertical devices	<ul style="list-style-type: none"> ▪ Vertical speed control devices with smooth and gradual surface transitions are generally preferred rather than horizontal devices that create squeeze points. Flat-top road humps with ramps of 1:15 to 1:20 relative to the gradient of the road are generally regarded as 'bicycle friendly'. Side slopes across the line of travel should not be severe. Transitioned ramps (e.g. sinusoidal humps) are recommended (Webster & Layfield 1998). Greater downhill speeds should be anticipated when considering humps on grades.

Source: Austroads (2008a) based on Section 8.12.1.

Figure 4.11 shows an example of a satisfactory bypass of a road hump in a residential street in the City of Booroondara, Victoria, in a situation where the relatively low motor vehicle volume does not justify a bicycle lane along the street. The surface of the bypass is well delineated to improve awareness of cycle use and conflict between cyclists and motor vehicles is unlikely on the departure from the device.

Figure 4.11: Example of good practice – cycle bypass of a road hump



Source: Courtesy of J. Hondrakis – Booroondara City Council.

Continuity of the bicycle/parking lane past treatments is important. Figure 4.12 shows what should not be done. Instead, the island should be positioned closer to the kerb and also offset from the traffic lane so that cyclists have sufficient space to pass between the island and the adjacent traffic lane.

Figure 4.12: Parked vehicle blocks cycle bypass



Source: Austroads (2008a) Figure 8.3.

Figure 4.13 shows an example of good practice to allow bicycles to bypass a half road closure. The bypass is of adequate width and there are no obstructions to sight lines and the pavement surface is smooth.

Figure 4.13: Cycle bypass at half road closure















Source: Austroads (2008a) Figure 8.4.

5. Provision for Cycling at Road Intersections and Interchanges

5.1 Introduction

This section describes cycling issues and facilities at intersections and interchanges. It presents bicycle treatments for signalised intersections, unsignalised intersections, roundabouts and road interchanges. It provides information on treatments which should be adopted, where necessary and practicable, to improve the safety and convenience for cyclists using intersections. Cross-references to the sections of Austroads Guides relevant to this topic are shown in Table 5.1.

Table 5.1: Key cross-references related to provision of cycling at road intersections and interchanges

Section of <i>Cycling Aspects of Austroads Guides</i>					
Guide	Section	Reference source	Guide	Section	Reference source
Section 5.1: Introduction					
	Section 3	Austroads (2009d)			
Section 5.2: Issues at Intersections for Cyclists					
	Section 3.4	Austroads (2013c)			
Section 5.3: Signalised Road Intersections (also Sections 7.6.3 and 9.5)					
	Section 10.6.7	Austroads (2010a)		Sections 3.4 and 5.3	Austroads (2013c)
	Section 7.6.11	Austroads (2014c)		Section 8	Austroads (2009b)
Section 5.4: Unsignalised Road Intersections (also Section 7.6.4)					
	Sections 4, 8.2.6 and 8.3.6	Austroads (2010a)		Section 3.4	Austroads (2013c)
Section 5.5: Roundabouts					
	Section 5.3 Commentary 1.2	Austroads (2011b)		Section 4.4.2 Commentary 17	Austroads (2013c)
Section 5.6: Road Interchanges (also Section 4.9)					
	Section 14	Austroads (2009e)		Section 6.4.4 Commentaries 23 and 24	Austroads (2013c)

Notes:



Guide to Road Design (GRD)



Guide to Traffic Management (GTM)

Where a bicycle lane exists or is planned on roads leading up to an intersection the design should assist the safe passage of cyclists through the intersection. In rural areas this may simply require an adequate clearance between the islands and left edge of the road to provide continuity of shoulders through the intersection. In urban areas it will often involve a bicycle lane marked through the intersection.

In catering for the needs of cyclists at intersections designs should conform to the standard approach and principles of traffic engineering design for all road users. This practice seeks to provide traffic facilities which clearly indicate the nature and extent of traffic movements and the potential conflicts. All road users, including cyclists, will benefit from a traffic environment which assists the road user to anticipate potential conflicts and encourages traffic awareness and predictable behaviour.

The types of lanes that may have to be incorporated into traffic routes, and therefore intersections, include:

- bicycle lanes
- bicycle/car parking lanes
- wide kerbside lanes.

These and other types of bicycle lanes are discussed in Section 4 in GRD 3 and Section 4 of this document.

Because of the wide range of ages and ability of cyclists, it is often necessary to accommodate off-road paths for young and/or inexperienced cyclists within intersection layouts.

5.2 Issues at Intersections for Cyclists

5.2.1 General

Common issues faced by cyclists and possible treatments are summarised in Table 5.2. A process to evaluate conflict for cyclists at intersections is provided in GTM 6.

Table 5.2: Issues for cyclists

Issue	Characteristics	Treatments
Squeeze points	Road narrows and separation between cyclists and motor vehicles reduces. Non-flush service pit covers, and sumps (New Zealand) that reduce the available width for cyclists.	<ul style="list-style-type: none"> ▪ Local widening⁽¹⁾ or remarking of traffic lanes to achieve a wide kerbside lane (where insufficient width is available for a bicycle lane). ▪ Bicycle lane. ▪ Bicycle/car parking lane. ▪ Shared path (provide where an on-road facility is impracticable and for use by young and inexperienced cyclists). ▪ Bicycle path. ▪ Add 'Watch for Bicycles' sign (AS 1742.9-2000, sign G9-57). ▪ Provide bicycle symbol and short continuity line in wide kerbside lane to increase motorist awareness of the presence of cyclists and to improve cyclist comfort (not permissible in New Zealand)⁽²⁾. ▪ Ensure that service covers and drainage assets do not reduce the road width available for safe use by cyclists.
Vehicle overtaking and immediately turning left into side street or driveway	Cyclist may crash into vehicle or have to take risky evasive action.	<ul style="list-style-type: none"> ▪ Bicycle lane to increase awareness⁽³⁾.
Motor vehicle converge and diverge areas	Cyclists are vulnerable when riding through the taper lengths of converge and diverge areas. Cyclists use left-turn lanes as a refuge from through traffic but cannot legally proceed in the 'through' direction if a left-turn arrow is marked in the lane.	<ul style="list-style-type: none"> ▪ Bicycle lane marked continuously throughout road or through converge and diverge areas with a continuity line⁽⁴⁾. ▪ Provide green surface treatment for bicycle lane.

Issue	Characteristics	Treatments
Lack of continuity and connectivity	Cyclists continually have to rejoin motor vehicle lanes because bicycle lane is terminated at squeeze points, resulting in hazardous movements.	<ul style="list-style-type: none"> Continuous bicycle lanes through unsignalised intersections where feasible. Provide green surfacing for bicycle lanes through hazardous areas or complex situations. If practicable, re-allocate road space used by other road users or for other purposes to achieve bicycle lane continuity. Erect 'Watch for Bicycles' signs at bicycle lane terminations (AS 1742.9-2000, sign G9-57).
Safely cross or join conflicting flows	Insufficient gaps in the traffic stream being crossed or joined.	<ul style="list-style-type: none"> Signalised cyclist crossing. Refuge island. Well-designed transition from shared path or bicycle path to an on-road bicycle lane i.e. physical protection for cyclist through alignment of left-side kerb (refer to GRD 4).
Gaining position to turn right	<p>Unsafe weaving manoeuvres on approach to major intersection.</p> <p>Space to wait and undertake right-turning manoeuvre.</p> <p>Difficult conditions turning right.</p>	<ul style="list-style-type: none"> Provide a bicycle lane on the left side of intersection approach and space for cyclists to store whilst making a 'hook turn'⁽⁵⁾. Locate a right-turn bicycle lane between the right-turn lane and through lane for motor vehicles (does not assist with weaving on the approach but provides some refuge). Provide adequate swept paths for cyclists to turn right with other vehicles, especially heavy vehicles including buses. Provide off-road path on periphery of intersection.
Cyclist not seen by motorists, or cyclist speed misjudged	Cyclist likely to be involved in a crash.	<ul style="list-style-type: none"> Provide bicycle lanes and logos to increase motorist awareness of the likely presence of cyclists. Erect 'Watch for Bicycles' signs (AS 1742.9-2000, sign G9-57). Reduce vehicle speeds through intersection using a physical device.
Loss of access	Road closure or provision of one-way streets could result in loss of access for cyclists.	<ul style="list-style-type: none"> Provide access for cyclists to pass through local road terminations and pedestrian malls. Provide contra-flow for cyclists on one-way streets in low speed environments.

1 Local widening or remarking traffic lanes should aim to provide a bicycle lane in the first instance.

2 May not be favoured in some other jurisdictions; check with relevant road authority.

3 Consider the provision of distinctive green surface in bicycle lane (refer to Section 9.4 of this document and Section 6.6 of GTM 10).

4 Where a bicycle lane cannot be achieved, install 'left lane must turn left, bicycles excepted' signs.

5 Provide cyclist indented storage area on the left side of the road to enable protected right-turn manoeuvre.

Note: This table provides a summary of key issues for cyclists; however, there are other cycling-related issues for cyclists at intersections (refer to the bicycle safety audit checklist in Appendix F of this document).

Source: Austroads (2013c) Table 3.3.

5.3 Signalised Road Intersections

5.3.1 General

Signalised intersections are often associated with traffic routes and are therefore utilised by commuter cyclists. Wherever practicable, traffic routes and signalised intersections should provide the space and operational conditions to support cycling as a viable alternative mode of transport. The needs of cyclists should be considered in relation to detection, signal phasing and timing, and road space. Off-road paths are often provided for non-commuter cyclists (e.g. the young and novice cyclists) and these paths often have to be incorporated into the functional layouts of signalised intersections. Traffic management considerations for cyclists at intersections are also provided in GTM 6.

The operation of traffic signals to accommodate cyclists is discussed in GTM 9 and traffic signal displays for cyclists in GTM 10. These topics are summarised in Section 9.5 of this document.

Practitioners are also referred to the *Effectiveness and Selection of Treatments for Cyclists at Signalised Intersections* report (Austroads 2011c), which examined the safety impacts of providing cycling facilities, in combination with other features, at signalised intersections. A key finding of this study was the substantial benefit of coloured cycle facilities.

5.3.2 Traffic Management Guidelines

The following tables provide key traffic management guidelines for consideration when designing signalised intersections. Table 5.3 and Table 5.4 cover cyclist requirements for arterial roads and local roads respectively whilst Table 5.5 covers lane management.

Table 5.3: Cyclist requirements for arterial road signalised approaches

Context	Guidelines
Bicycle lanes at intersection approach and departure	<p>Bicycle lanes should be provided on intersection approaches where:</p> <ul style="list-style-type: none"> ▪ the route is a designated bicycle route ▪ bicycle lanes are marked mid-block ▪ squeeze points exist for cyclists and it is feasible to develop sufficient space for the bicycle lane ▪ the layout of the intersection results in high traffic volumes or relatively high speed vehicles weaving across the path of cyclists. <p>As a guide, consider a bicycle lane where the traffic volume is > 3000 vehicles per day and/or there is a significant percentage of heavy vehicles.</p> <p>Where appropriate, consider the provision of an exclusive lane for right-turning cyclists, placed between the right-turn lanes and through lanes for motor vehicles. Consideration should also be given to the manner in which right-turning cyclists may gain access to the bicycle lanes.</p> <p>In Australia, cyclists are generally permitted to undertake a 'hook turn' at intersections instead of a conventional right turn (refer to <i>Australian Road Rules</i> and Figure 5.11). This option is often used by cyclists at signalised intersections where they can complete the manoeuvre with a green signal, after waiting at the intermediate corner. Provision of a storage area at the corner is not common; however, additional space may be provided by setting back the pedestrian crosswalk lines and stop line on the intersecting approach. This 'head start area' (refer to Section 5.3.5) may be marked with bicycle logos.</p> <p>Bicycle lanes should be provided on the departure side of intersections where:</p> <ul style="list-style-type: none"> ▪ a bicycle lane exists or is planned along a route ▪ cyclists are required to weave through high volumes of traffic merging from the left (i.e. left-turning traffic joining the route) or high-speed merging traffic.
Intersection stop-line storage	<p>On bicycle routes a 'head start area' (refer to Section 5.3.5) should be considered, to allow for cyclists to wait at the stop line at a position in advance of the motor vehicles. This facility ensures that cyclists waiting at the red light are visible to the first driver in the queue, particularly drivers of commercial vehicles that may have their view of cyclists impeded by the height of the left door of the vehicle.</p>
Bicycle paths, shared paths and separated paths	<p>Where paths exist along a route they should continue through the intersection desirably via shared pedestrian/cyclist crossings that are appropriately marked. The provision of hand rails to assist cyclists to remain mounted whilst waiting for a green signal should be considered.</p>

Source: Austroads (2013c) Table 5.2.

Table 5.4: Cyclist requirements for local road signalised approaches

Context	Guidelines
Local streets	<p>Cyclists are expected to share traffic lanes on local streets (typically less than 3000 vpd) except where the street forms part of a designated bicycle route with marked lanes.</p>
Collector – distributor roads	<p>Where sufficient width is available, bicycle lanes should be provided on these roads and at the approaches to signalised intersections.</p>

Source: Austroads (2013c) Table 5.3.

Table 5.5: Lane management at signalised intersections for on-road bicycle lanes

Context	Guidelines
On-road bicycle lanes	<ul style="list-style-type: none"> On-road lanes are designated by standard bicycle lane signs (usually located beside the road but sometimes overhead.). However, in New Zealand road markings without signs can define a bicycle lane; refer to Land Transport (Road User) Rule 2004 (New Zealand) and NZ Transport Agency 2010a and 2010b). Are generally delineated with a continuous lane line (except in motor vehicle diverge and merge areas where two continuity lines are used) and bicycle logos. The <i>Australian Road Rules</i> limit motor vehicle travel along a bicycle lane to a distance of 50 m, in order to turn left. Pavement arrows may be used to define directional use of a bicycle lane (e.g. right-turn arrow in a bicycle lane that is situated between the through lane and right-turn lane for motor vehicles). A green surface may be provided to enhance the delineation of a lane in relatively hazardous or complex situations, refer to Section 9.4 of this document, Section 6.6 of GTM 10 and Austroads (2011c).

Source: *Guide to Traffic Management* (Austroads 2013c) Table 5.4.

5.3.3 The Six Elements

Figure 5.1 illustrates six elements of a signalised intersection where, ideally, visually separated operating space should be provided. However, where space is constrained and all elements cannot be satisfactorily addressed designers should meet as many of the requirements as possible. Design options for the six elements are shown in Figure 5.2 and Figure 5.3.

Figure 5.1: Provision of a bicycle operating space at intersections – the six elements

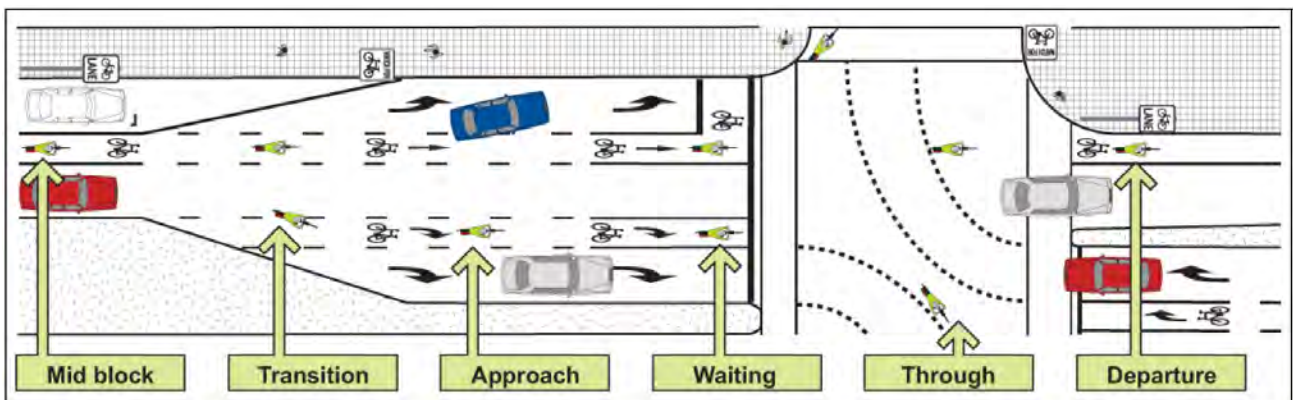

Source: Austroads (2010a) Figure 10.6 and Roads and Traffic Authority NSW (2005).

Illustrations of exclusive right-turn lanes for cyclists are shown in this section. However, these right-turn lanes are rarely used and should generally not be provided for cyclists at right-turn treatments on arterial roads or busy traffic routes because of the difficulty and crash risk for cyclists moving from the left of the road on an intersection approach to the centre of the road in order to utilise such treatments. Where right turn bicycle lanes are provided for cyclists it is essential that adequate clearance is provided between motor vehicle swept paths to ensure that opposing right-turning cyclists can operate safely and do not come into conflict with each other.

Exclusive right-turn lanes for cyclists would only be provided where:

- it can be demonstrated that the volume of traffic on an arterial road/traffic route is low enough for cyclists to be able to safely access the cyclist right-turn lane, and there is sufficient cyclist demand to justify the facility
- the speed environment is very low (e.g. 50 km/h limit) and cyclist demand is significant.

These conditions may exist within the business centres of cities or activity centres and may be associated with particular precincts (e.g. universities or sporting and recreational areas).

Figure 5.2: Design options for signalised intersections (mid-block, transition and approach)

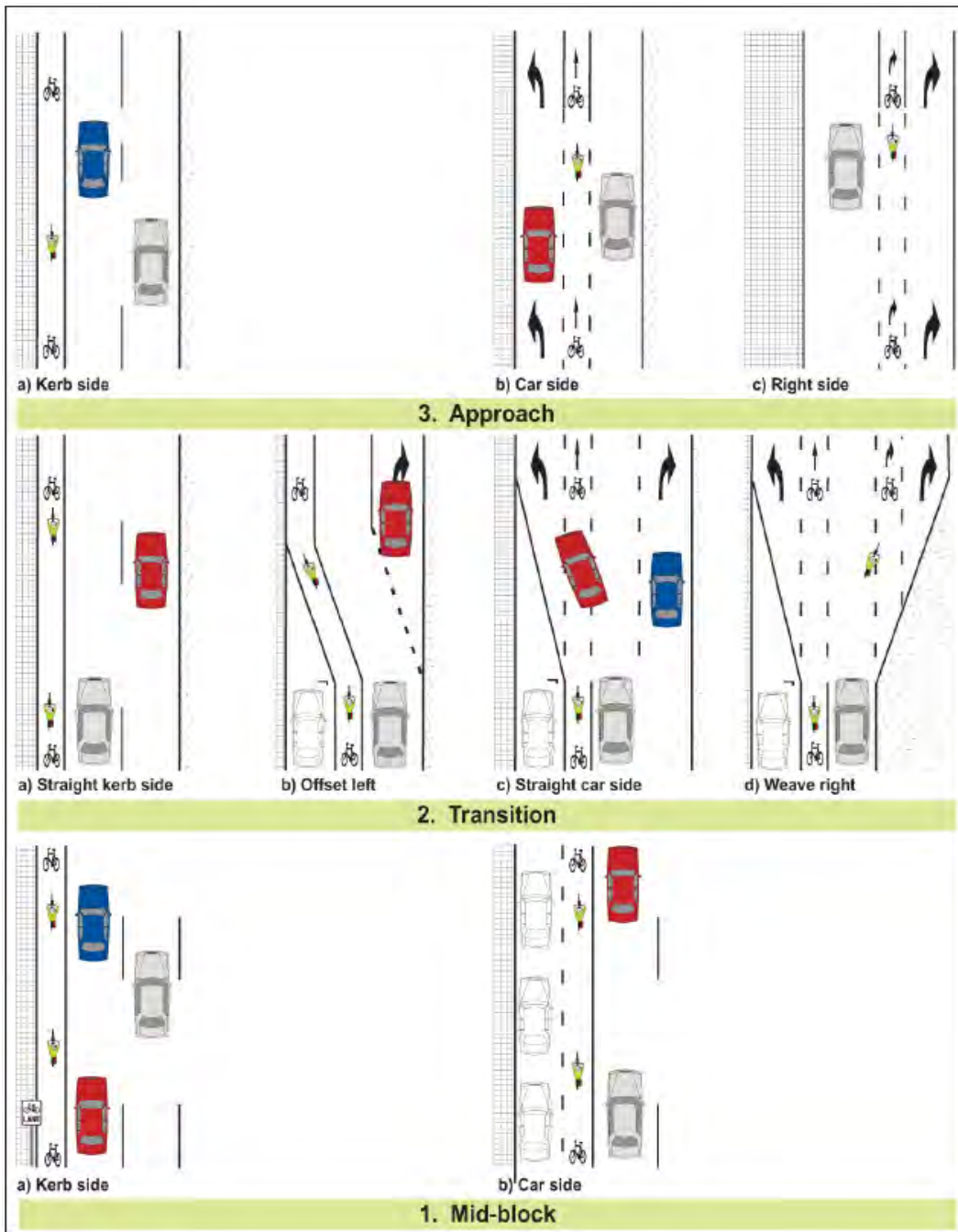

Source: Austroads (2010a) Figure 10.7 and Roads and Traffic Authority NSW (2005).

Figure 5.3: Design options for signalised intersections (waiting, through and departure)

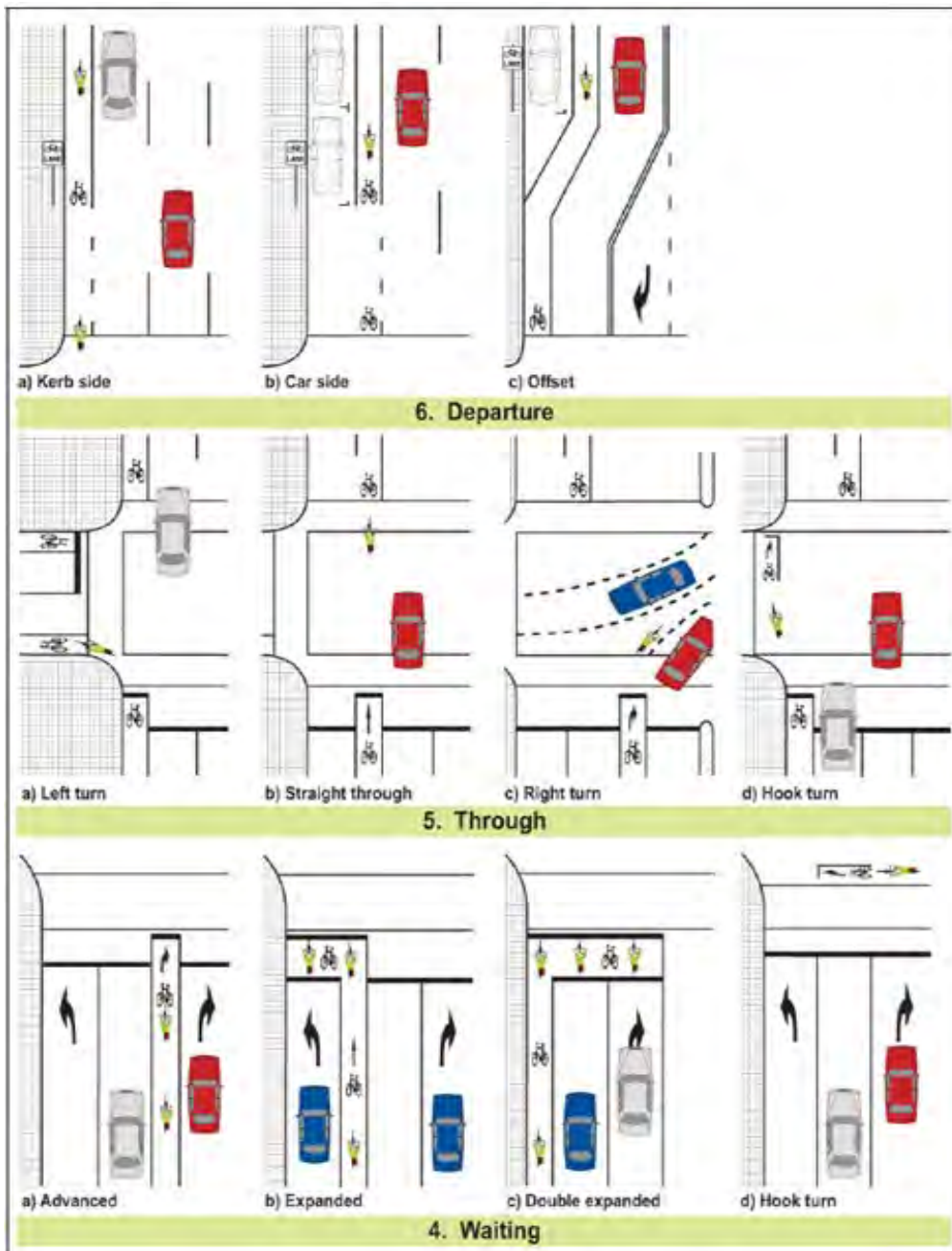

Source: Austroads (2010a) Figure 10.8 and Roads and Traffic Authority NSW (2005).

Where practicable, it is desirable that the hook turn storage areas shown in Figure 5.3 are sufficiently wide for cyclists to orientate their bicycles in the intended direction of travel.

5.3.4 Bicycle Lanes

Figure 5.4 shows two common examples of bicycle lanes marked at signalised intersections where the width between kerbs is approximately 13 m and parking is provided. In the car-side option no separate left-turn lane is provided for cyclists resulting in them having to make the left turn from the vehicle lane and the expanded storage box. Cyclists using the kerbside option can turn left or proceed straight through the intersection from the bicycle lane. Both options can be applied to bicycle/car parking lanes and exclusive bicycle lanes.

Figure 5.4: Bicycle lanes through signalised intersections – car side and kerbside

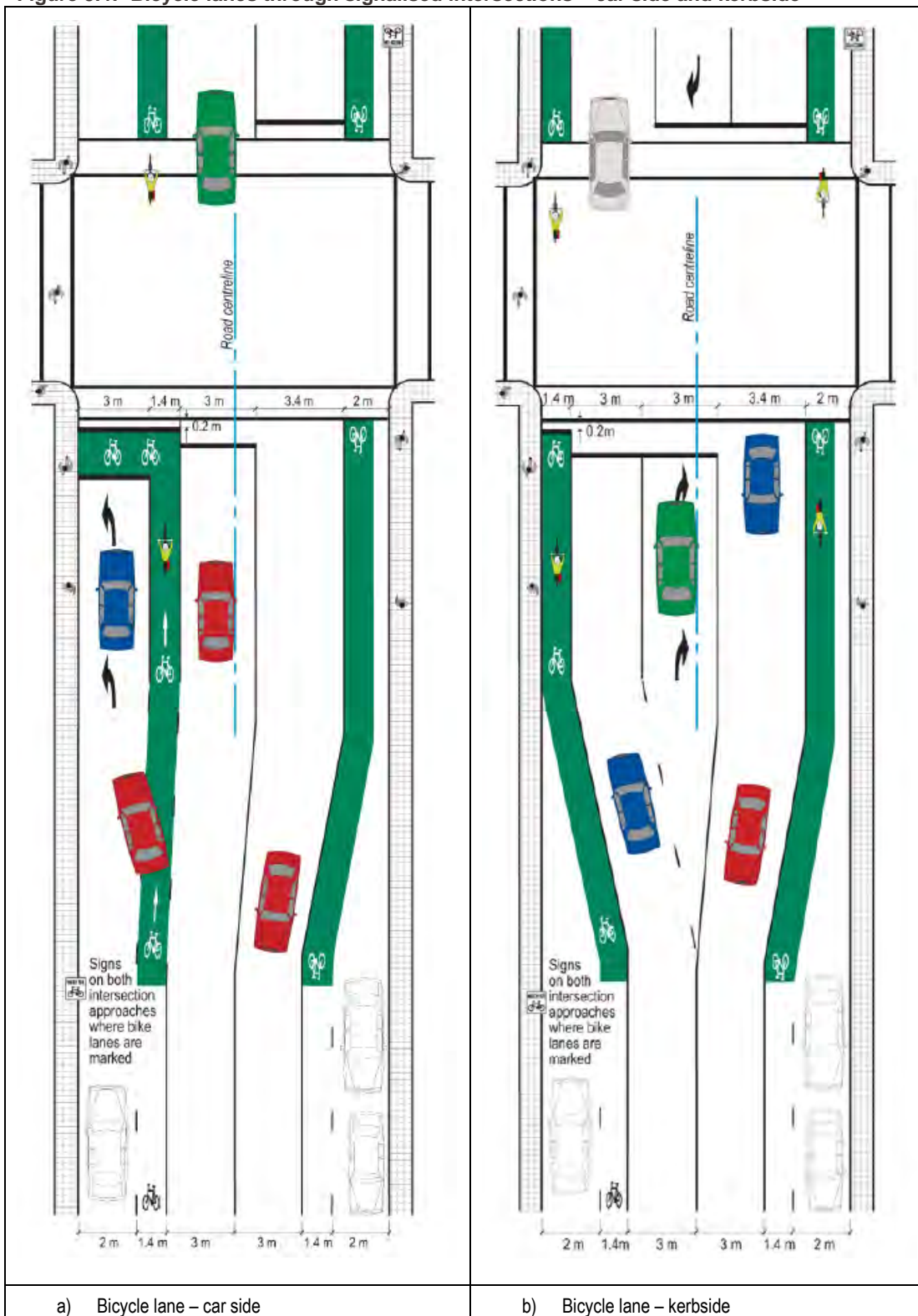

Note: It should be noted that in Figure 5.4(a) conflict may occur between left-turning motor vehicles and cyclists at the entry to the left-turn lane, and in Figure 5.4(b) a similar conflict may occur in the vicinity of the intersection corner.

Source: Austroads (2010a) Figure 10.9 and Roads and Traffic Authority NSW (2005).

5.3.5 Head-start and Expanded Storage Areas

These storage areas are provided to position cyclists in a highly visible location while they are waiting to proceed through the intersection, thereby improving safety. Figure 5.5 shows four combinations of head-start and expanded storage areas at signalised intersections. The required length of the head-start area (LHS) varies depending on the number of bicycles that need to be stored. The treatments in each of the four examples can be used in isolation or in any combination. A summary of the various treatments is provided in Table 5.6.

Figure 5.5: Head-start and expanded storage areas

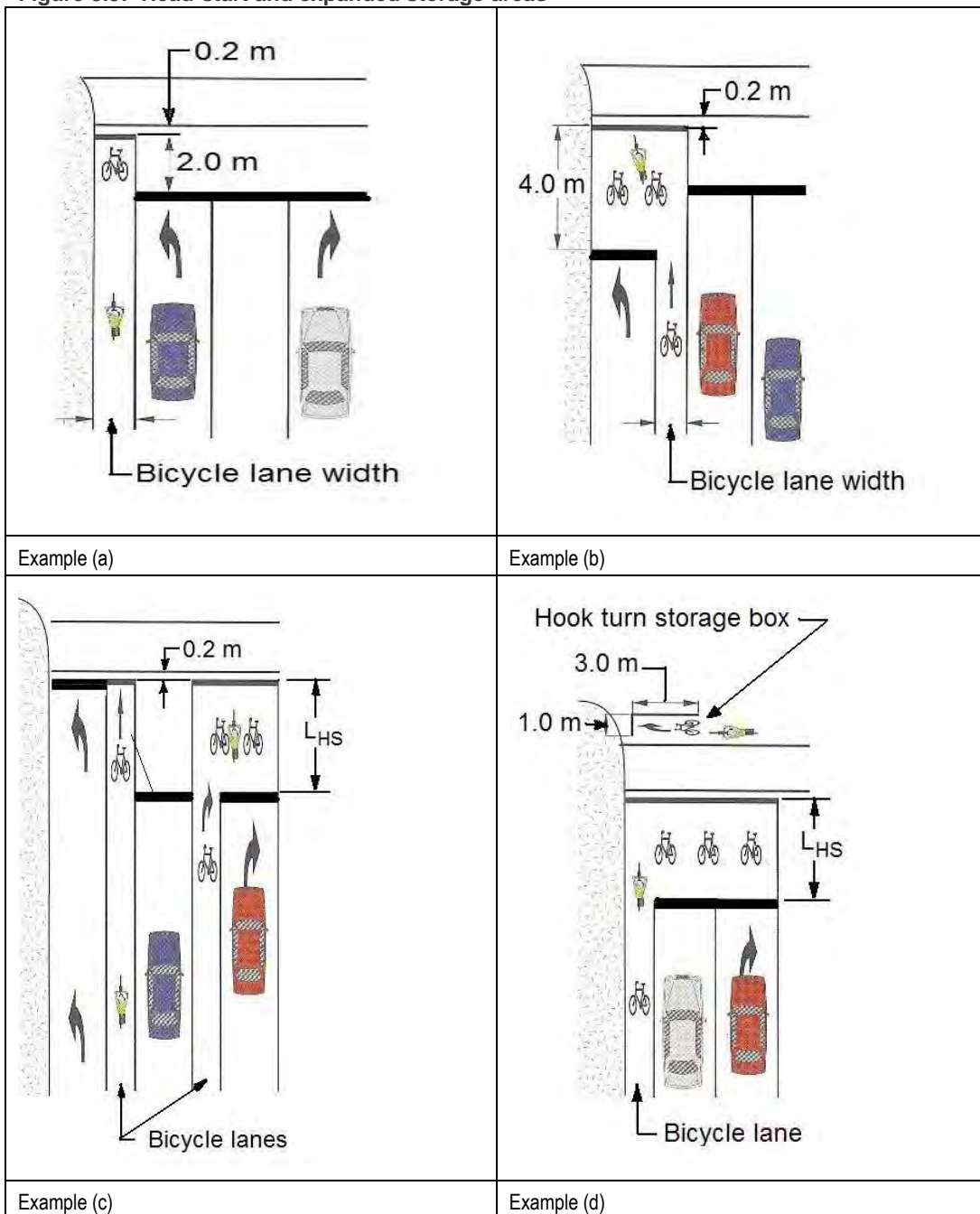

Note: LHS denotes length of head-start area.

Source: Austroads (2010a) Figure 10.10, based on Roads and Traffic Authority NSW (2005).

Table 5.6: Summary of use of the head-start treatments illustrated in Figure 5.5

Example	Purpose	Comment
Example (a)	<p>The purpose is to store a cyclist in advance of a motor vehicle driver in the adjacent left-turn lane or through lane so that the cyclist can be easily seen by a stationary driver at the stop line.</p> <p>This is particularly important where the vehicle is a van or truck in which case the cyclist would otherwise be hidden from view below the left-hand side window.</p>	<p>This treatment:</p> <ul style="list-style-type: none"> reduces the potential for conflict between cyclists and traffic using the left lane is suitable where cyclist numbers are relatively low allows cyclists to pass on the left side of a queue of vehicles waiting to turn left has an area that is only as wide as the bicycle lane on the approach has a bicycle stop line that is located 0.2 m in advance of the pedestrian crosswalk line and 2.0 m (i.e. storage length for one bicycle) beyond the motor vehicle stop line may be placed to the left of a left-turn lane, a through lane, or a combined through and left-turn lane.
Example (b)	<p>This treatment locates the bicycle lane between the left-turn lane and through lane and as a consequence provides additional storage width and length.</p>	<p>Cyclists travelling straight ahead travel to the right of queued or moving left-turning vehicles.</p> <p>Left-turning vehicles are required to change lanes across the bicycle lane at the start of the left-turn lane.</p> <p>Cyclists intending to turn left should desirably share the left-turn lane with motor vehicles. However, it is likely that some left-turning cyclists will use the bicycle lane to pass the queue and access the storage box.</p>
Example (c)	<p>This illustration includes two treatments that provide a head start for through cyclists and right-turning cyclists (with expanded storage).</p>	<p>The first treatment is a bicycle lane for cyclists travelling straight through the intersection. In this case left-turning cyclists are expected to share the left-turn lane with motor vehicles.</p> <p>The second treatment is a right-turn expanded storage area for high volumes of bicycle turning traffic. These treatments:</p> <ul style="list-style-type: none"> are rarely used and are not intended for use in higher speed zones (> 60 km/h) because of the difficulty and conflict associated with cyclists crossing traffic lanes to access the right-turn bicycle lane may be appropriate in lower-speed zones (\leq 60 km/h) where bicycle volumes are high and the turn is made into a single-lane mixed function road that does not have marked bicycle lanes (e.g. inner city areas). <p>Where bicycle lanes are provided in the intersecting road and bicycle turning volumes are not high, it is more acceptable to install a head-start storage area only in the right-turn bicycle lane. In this instance it is also necessary to include additional turning lines within the intersection to guide right-turning cyclists and delineate the cyclists' path for drivers.</p>
Example (d)	<p>This example also shows two treatments that provide storage expanded across two traffic lanes and a formalised hook-turn treatment.</p>	<p>The first treatment is a hook turn storage area, provided to accommodate cyclists in a safer position while they are waiting for a green traffic signal phase for the intersecting road, and can be used generally throughout the road system.</p> <p>The second treatment, an expanded storage area shared by left-turning, through and right-turning cyclists is suitable only for lower speed areas (e.g. 50 km/h).</p>

Source: Austroads (2010a) summarised from Section 10.6.4.

In high traffic locations or where the number of bicycle turning movements is significant, or compliance by motor vehicle drivers is poor (i.e. encroachment into bicycle storage area) it may be necessary to improve the delineation of the storage area by paving it with a green surface. It should be noted that:

- not all jurisdictions use head-start areas across multiple lanes, particularly through lanes
- a head-start area may be used where there is no bicycle lane on the intersection approach.

The treatment in Example (a) is not suitable for use where a green left-turn arrow is provided on the approach as the treatment encourages cyclists to store at the stop line. Even without the treatment left-turn phases are problematic for through cyclists waiting in the vicinity of the stop line. The bicycle lane for the through cyclist movement depicted in Example (c) can remove this conflict and should be used where a left-turn phase is provided.

In practice many cyclists intending to turn right ride to the left of motor vehicles which are turning or intending to turn right in order to avoid conflict with this traffic stream. This means that they may be exposed to conflict with through motor traffic. The right-turn bicycle lane shown in Example (c) creates space for cyclists, providing protection from moving motor vehicles and enabling cyclists to easily advance to the head of the right-turning queue.

If the volume of cyclists is high then consideration may be given to providing a larger storage area as shown in Examples (c) and (d).

5.3.6 Hook Turn Storage Boxes and Hook Turn Restrictions

Under the *Australian Road Rules*, cyclists on an approach at a signalised intersection can use a hook turn as an alternative to a conventional right turn from the centre of the road. Cyclists undertake a hook turn by travelling straight at the intersection and waiting at the far corner of the intersecting road. Where the aim is to encourage the use of hook turns, or to ban a conventional right turn that may be hazardous to cyclists, a hook turn storage box can be provided as illustrated in Figure 5.5(d) and Figure 5.6.

The hook turn box should not be located as illustrated if the left-turn lane has a signalised left-turn arrow. In this case the box may be placed in front of the adjacent lane if the signal phasing permits. Additional in-ground signal detection in the hook turn box should be considered where the box is placed at a side street approach to a major road to ensure that cyclists can call a phase.

It should be noted, however, that the box turn may be illegal in some states and the traffic signal phasing at some intersections may not suit a hook turn. For instance, waiting cyclists who have performed the first stage of a hook turn manoeuvre could be in conflict with an exclusive left-turn phase for the intersecting road (in which case the box should be located to avoid this conflict; refer to notes under Figure 5.6) or a diagonal pedestrian crossing phase.

Figure 5.6: Bicycle hook turn box detail

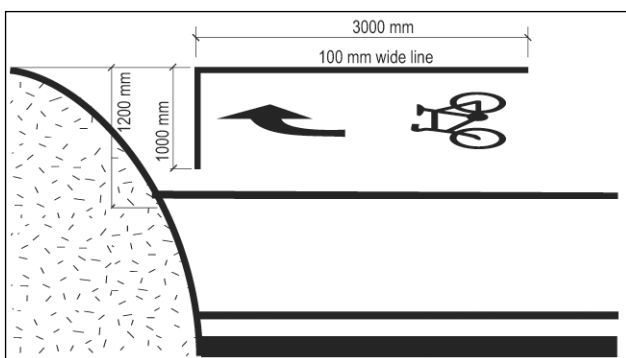

Notes:

- In this case the hook turn box is located in the area between the crossing line or vehicle stop line and the crossroad kerb line.
- The hook turn box should not be located in this position if the left lane has a signalised turn phase. In this case the bay may be located in front of the adjacent traffic lane if signal phasing permits.
- Additional in-ground signal detection should be installed in hook turn boxes where the box is located at a side street entrance to a major arterial road with signal priority.

Source: Austroads (2010a) Figure 10.11 and Roads and Traffic Authority NSW (2005).

5.3.7 Left-turn Treatments

It is often necessary to provide bicycle lanes as part of channelised left-turn treatments (CHL). High-entry angle or free-flow left-turn treatments may be provided at signalised intersections and bicycle lanes may be required within the layout to provide convenient and safer operating space for cyclists.

High-entry angle treatment

The treatment is illustrated in Figure 5.7 where a bicycle lane provides separation for cyclists through the diverge area on the approach to the intersection and at the stop line. The bicycle lane provides an offset to the island nose and the side of the island is parallel to the adjacent traffic lane. Generally cyclists share the left-turn lane with motor vehicles; however, where the volume of left-turning cyclists is high it may be appropriate to provide a bicycle lane within the left-turning roadway. If a significant number of cyclists turn left at a CHL treatment then provision of a bicycle lane adjacent to the kerb within the left-turn roadway should be considered.

Figure 5.7: Provision for cyclists at a signalised CHL treatment in a low-speed environment

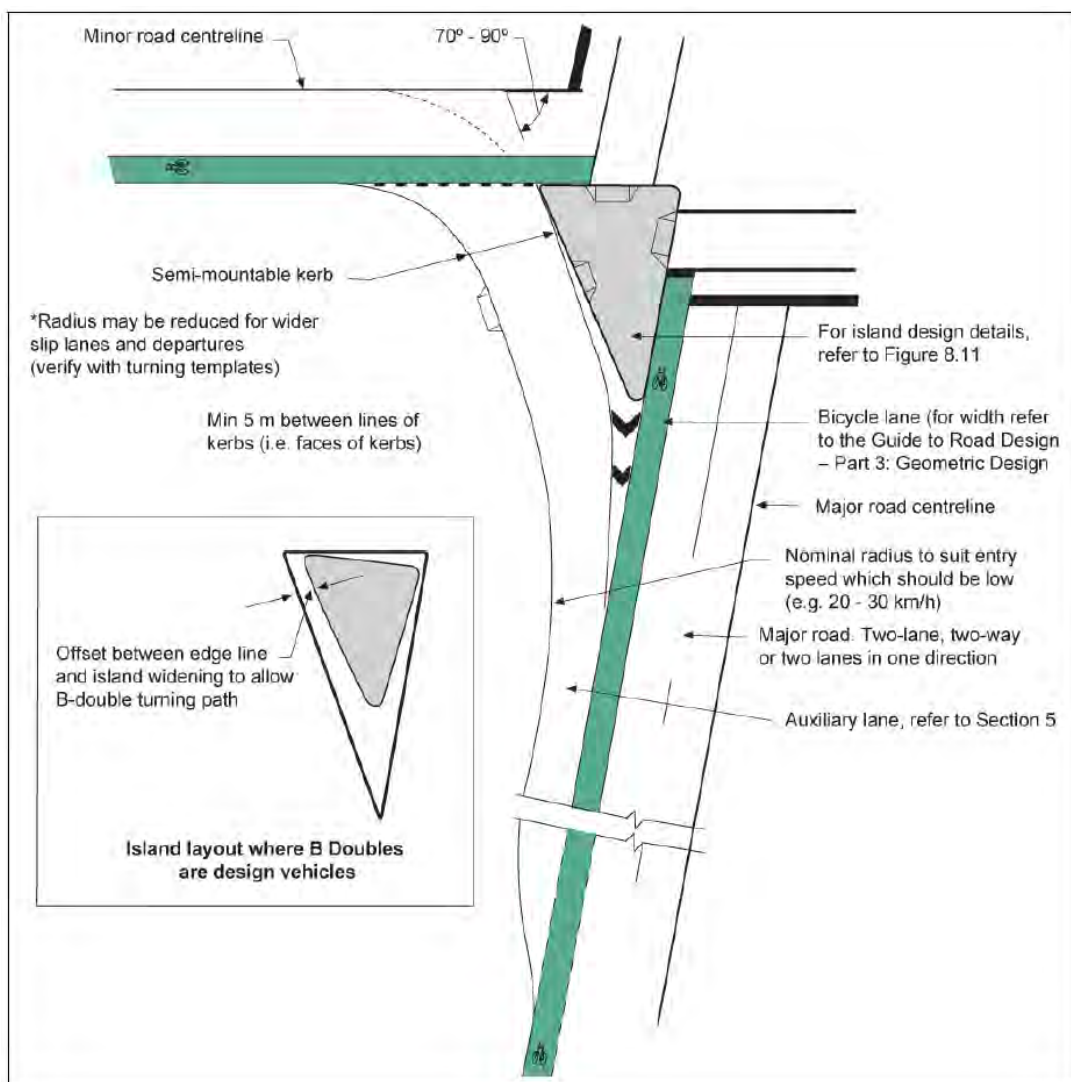

Source: Austroads (2010a) Figure 8.15.

Free-flow CHL treatment

Figure 5.16 in Section 5.4.3 illustrates a free-flow left-turn island at an unsignalised intersection that incorporates a treatment designed to discourage cyclists from travelling in a path between the auxiliary lane and the adjacent through lane and being caught between through traffic and merging traffic. The layout shown can be readily adapted to a signalised intersection by providing stop lines, pedestrian crosswalk lines, pedestrian ramps, continuity lines for that portion of the bicycle lane within the intersection and probably a signalised crossing of the left-turn roadway.

Left-turn bypass treatment

Left-turn access through signals may be provided for cyclists where a major bicycle route turns left through a signalised intersection as shown in Figure 5.8. This treatment has a bicycle lane in the intersecting road. Where there is no bicycle lane in the intersecting road the bypass should be designed as a free-flow arrangement where the bicycle lane is directed into an off-road path parallel to the intersecting road to join it with a protected transition (kerb extension).

Figure 5.8: Bicycle lane left-turn bypass at a signalised intersection

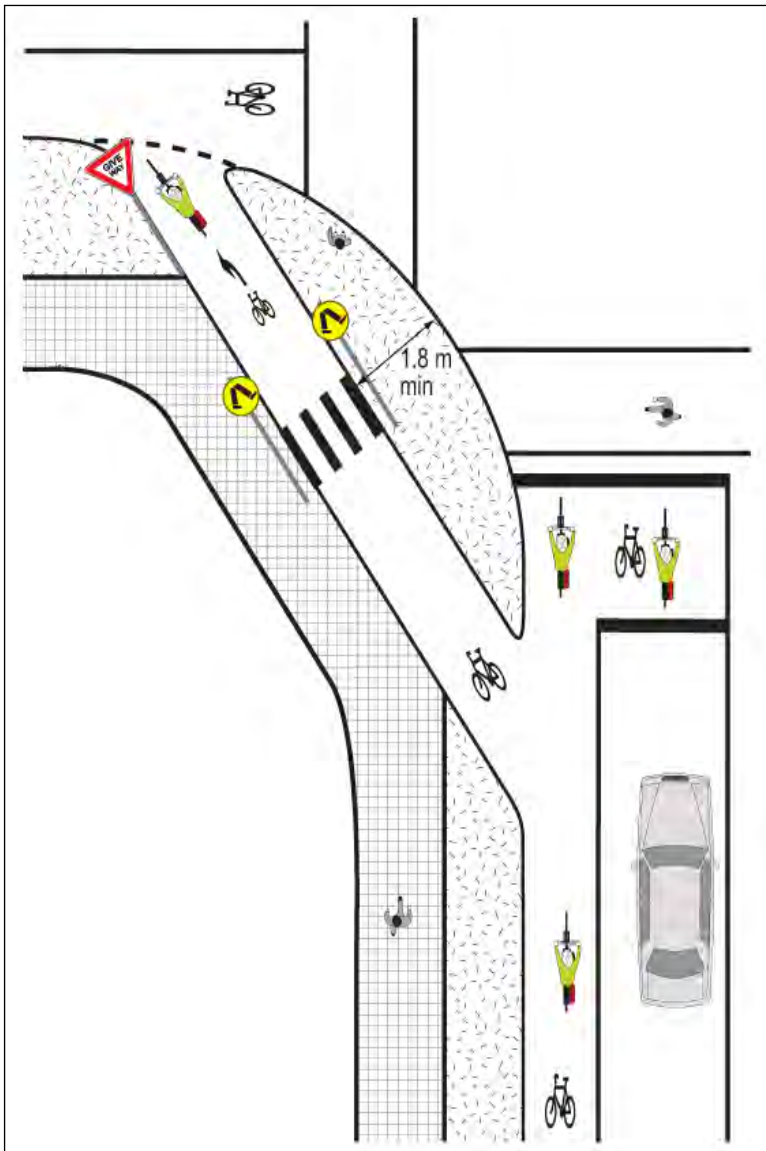

Source: Austroads (2010a) Figure 10.12 and Roads and Traffic Authority NSW (2005).

5.3.8 Bypass of T-intersection

In order to limit the delay to cyclists at T-intersections, circumstances may permit the construction of a bypass of the intersection for cyclists opposite the discontinuing leg of an intersection, as shown in Figure 5.9. The bypass may be separated by channelisation as shown or a separated path treatment can be used where the bicycle path is raised and adjacent to the footpath. A disadvantage of the channelised treatment may be the accumulation of debris and the consequent maintenance. Use of the treatment is covered in GRD 4A.

Figure 5.9: Cyclist bypass lane at a signalised T-intersection

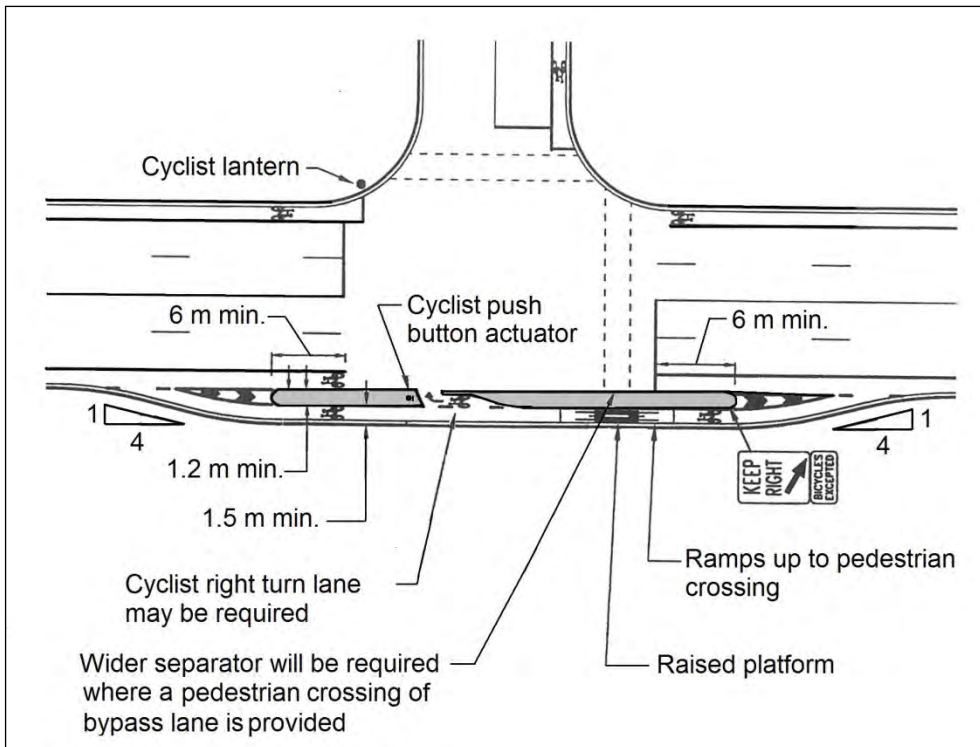

Source: Austroads (2010a) Figure 10.13.

5.3.9 Crossings at Signalised Intersections

General

It is often necessary to integrate off-road bicycle facilities with other road user requirements at signalised intersections. The design should ensure that the movements of cyclists are managed and regulated to provide safer interaction of cyclists with pedestrians and motor vehicles.

The facility to be integrated may be a shared path, an exclusive bicycle path, or a separated path. Where a shared path passes through an intersection cyclists are expected to share the marked foot crossing with pedestrians. Where a bicycle path or a separated path is to be accommodated the cyclists and pedestrians will usually be separated on the crossing.

Separated path crossing

Figure 5.10 shows an example of a multi-lane road intersection with off-road bicycle paths on one road and a shared path on the other road in a constrained road reservation. In this case the various paths adjoin and cross parallel to the intersecting roads. This example shows two-way bicycle paths on both sides of one road and shared paths on both sides of the intersecting road. For this type of treatment it is desirable to have separate detection and lanterns for cyclists and pedestrians (refer to Section 9.5, GTM 9 and GTM 10).

Figure 5.10: Shared path and two-way bicycle path at a signalised intersection

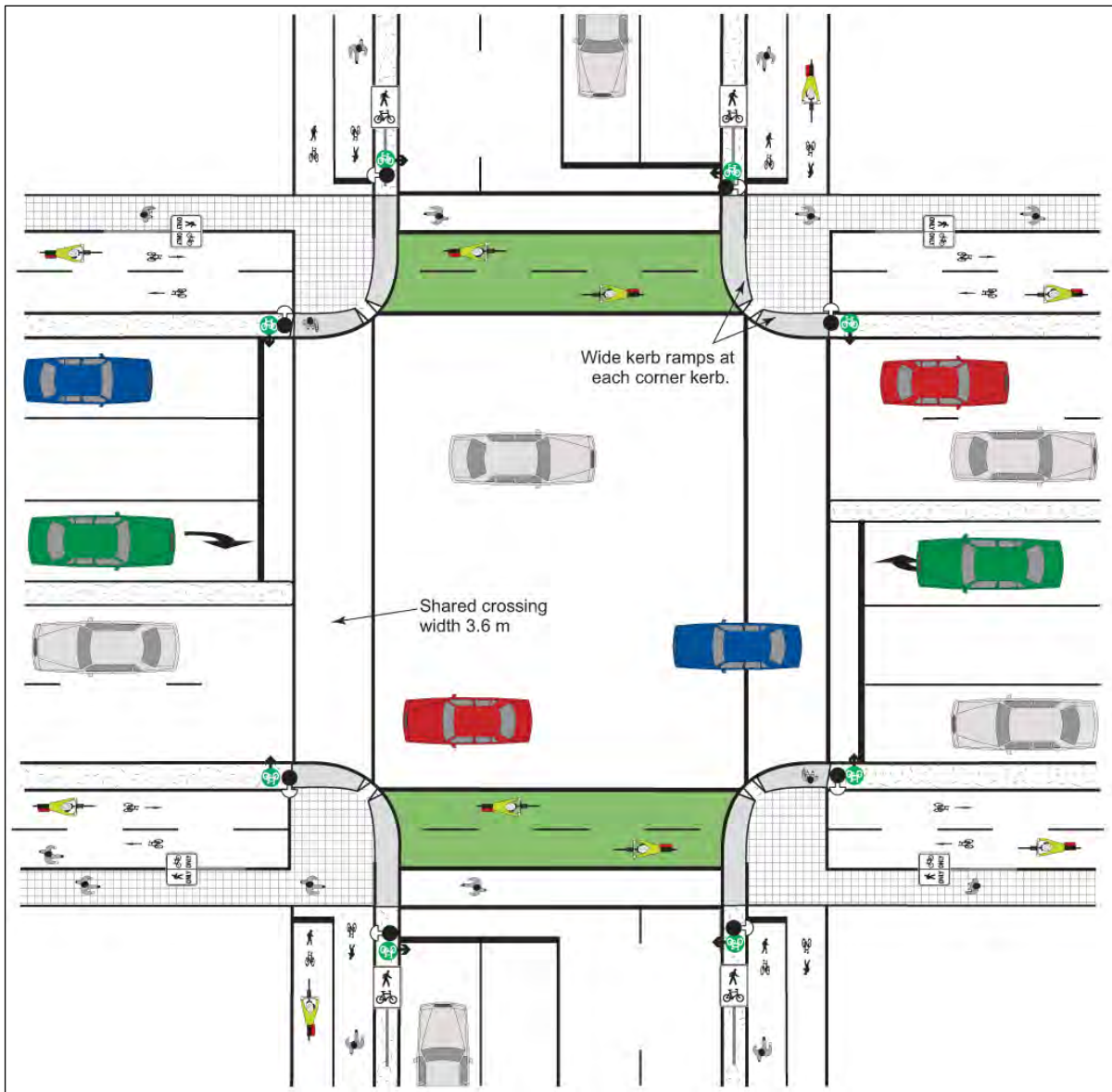

Notes:

Only the additional bicycle signal lamps are shown, not the complete traffic signal layout.

In-path or other remote detection is recommended for bicycle paths.

The width of the marked crossing for separated paths should match the width of the paths on the approach.

At intersections where the volume of cyclists and pedestrians is high it is advisable to provide contrasting surfaces to delineate the use and priority of movement.

Source: Austroads (2009d) Figure 9.6, based on Roads and Traffic Authority NSW (2005).

Where off-road bicycle routes are required to pass through major intersections, signal control should be considered for left-turn slip lanes. The designer should aim to provide a similar level of service through the intersection for cyclists as for motor vehicles. Desirably the signal phasing and timing should enable cyclists to pass through the intersection in one stage. Where practicable pedestrian and cyclist crossings should be separated; however, where this is not possible cyclists will have to share the crossing with pedestrians.

It is important that:

- the design and markings are designed to minimise conflict between cyclist and pedestrians
- where appropriate, bicycle detection loops are provided
- where provided, bicycle activation buttons (similar to pedestrian buttons) are located in a convenient position close to the crossing approach or holding line
- adequate queuing and storage space is provided for cyclists
- additional width is allowed for cyclists starting up at the signals.

Right turns from off-road bicycle paths

The treatment shown in Figure 5.11 is similar to that used at large signalised intersections to assist bicycle hook turns between a separated path and a bicycle lane on the intersecting road. Up to four bicycles can be accommodated in this area while waiting for a green right-turn arrow. If the cyclist volume is high, green pavement surfacing should be considered on both the holding area and the bicycle crossing.

Figure 5.11: Right turn from an off-road bicycle path to an on-road bicycle lane

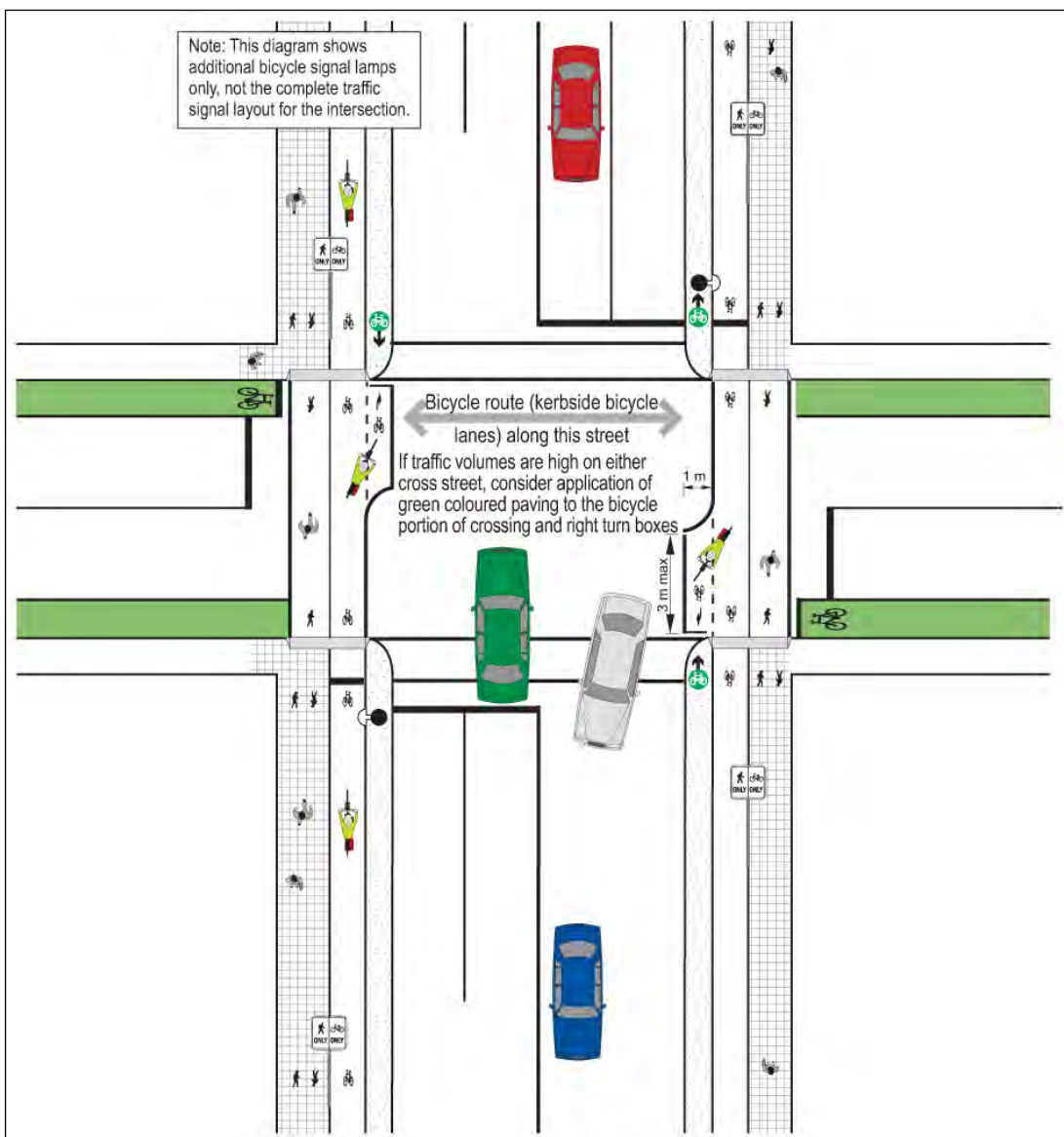

Source: Austroads (2009d) Figure 9.7, based on Roads and Traffic Authority NSW (2005).

5.3.10 Signalised Mid-block Crossings

Road crossings for cyclists can be coordinated with signalised or unsignalised pedestrian crossings and school crossings. Cyclists are usually required by law to dismount at formal pedestrian crossings including school crossings. Where a bicycle route crosses a road at a signalised crossing care should be taken to ensure that activation buttons are located to avoid the need for cyclists to cross in front of oncoming path users and are within easy reach for a mounted cyclist. Induction loops can also be installed to facilitate detection.

Bicycle crossing lights (i.e. displaying bicycle symbols) should be provided where the crossing serves both pedestrians and cyclists provided jurisdictional traffic regulations permit this treatment. Where road rules permit, a green bicycle signal allows cyclists to ride across the crossing. Where pedestrian and cyclist demands are both heavy there is a tendency for pedestrians to move to the front and block the progress of cyclists using the crossing. In such cases consideration should be given to segregating cyclists and pedestrians as shown in Figure 5.12 (i.e. separate and well-delineated crosswalks for pedestrians and cyclists).

The appropriate type of crossing should be determined with reference to normal warrants for pedestrian crossings using the combined cyclist and pedestrian demand.

Figure 5.12: Signalised crossing with separate pedestrian and cyclist areas

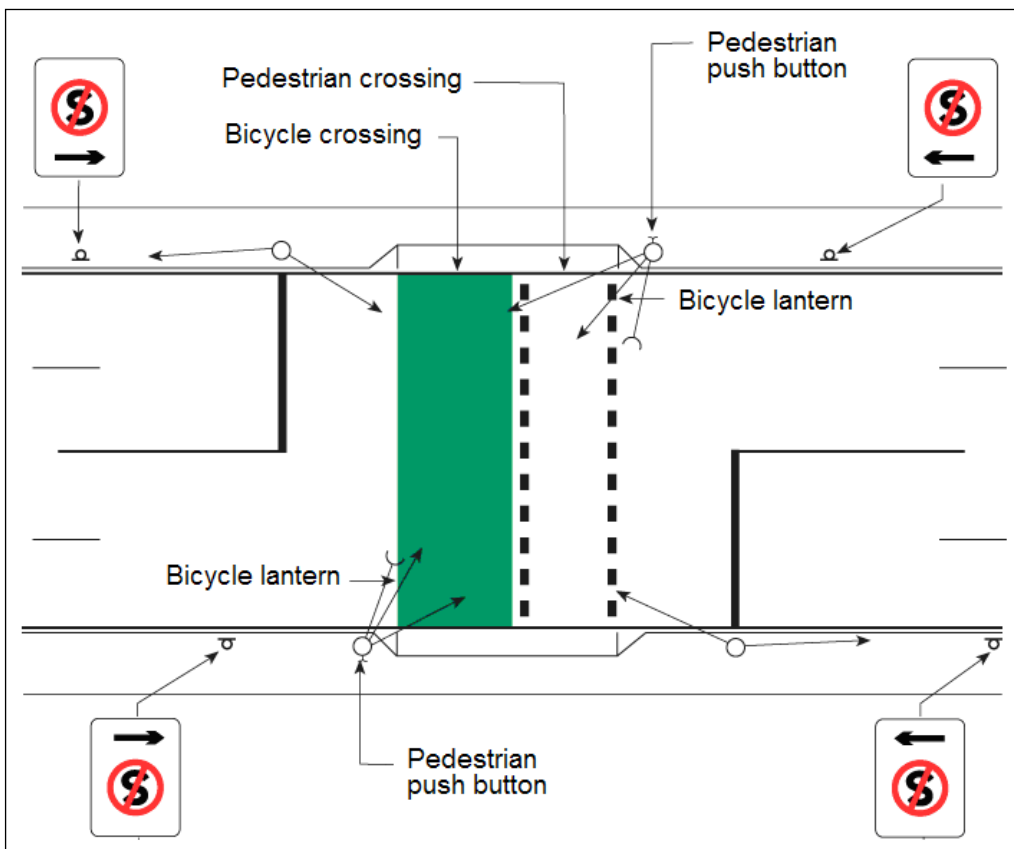

Note: The intent of the green surfacing is to improve the discipline of cyclists and pedestrians in using their respective areas of the crossing. However, the delineation of the crossing, and hence the use of green surfacing, is a matter for the relevant road authority.

Source: Austroads (2009d) Figure 9.5.

5.4 Unsignalised Road Intersections

5.4.1 General

This section covers treatments designed to assist cyclists to safely negotiate unsignalised intersections between two roads or between a road and a bicycle path or shared path. However, path terminal treatments are not included as they are discussed in Section 7.8 of this document and Section 10 of GRD 6A.

5.4.2 Basic and Channelised Intersections

Figure 5.13 and Figure 5.14 respectively illustrate the provision of bicycle lanes through basic and channelised intersection treatments for urban situations. Further information and examples on the integration of bicycle facilities into unsignalised intersections is provided in GRD 4A. The most important requirements are that the bicycle lanes should be continuous through the intersection and be well delineated as a space for cyclists by appropriate placement of pavement logos, and use of a green surfacing where necessary (e.g. in complex treatments or high-risk situations).

Figure 5.13: Urban basic (BA) intersection turn treatments

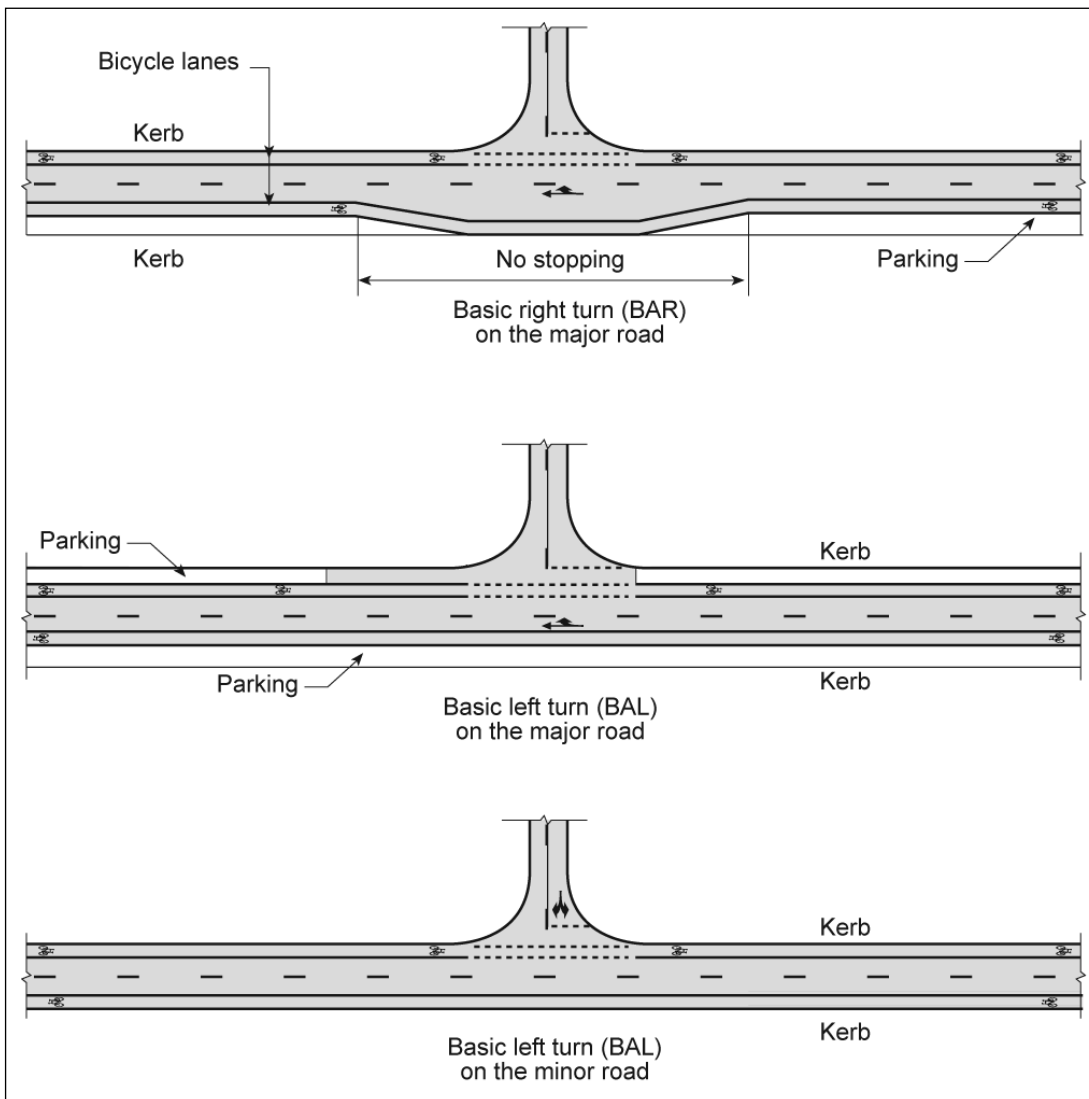

Note: Arrows indicate movements relevant to the turn type. They do not represent actual pavement markings.

Source: Austroads (2013c) Figure 2.2.

Figure 5.14: Urban channelised (CH) intersection turn treatments

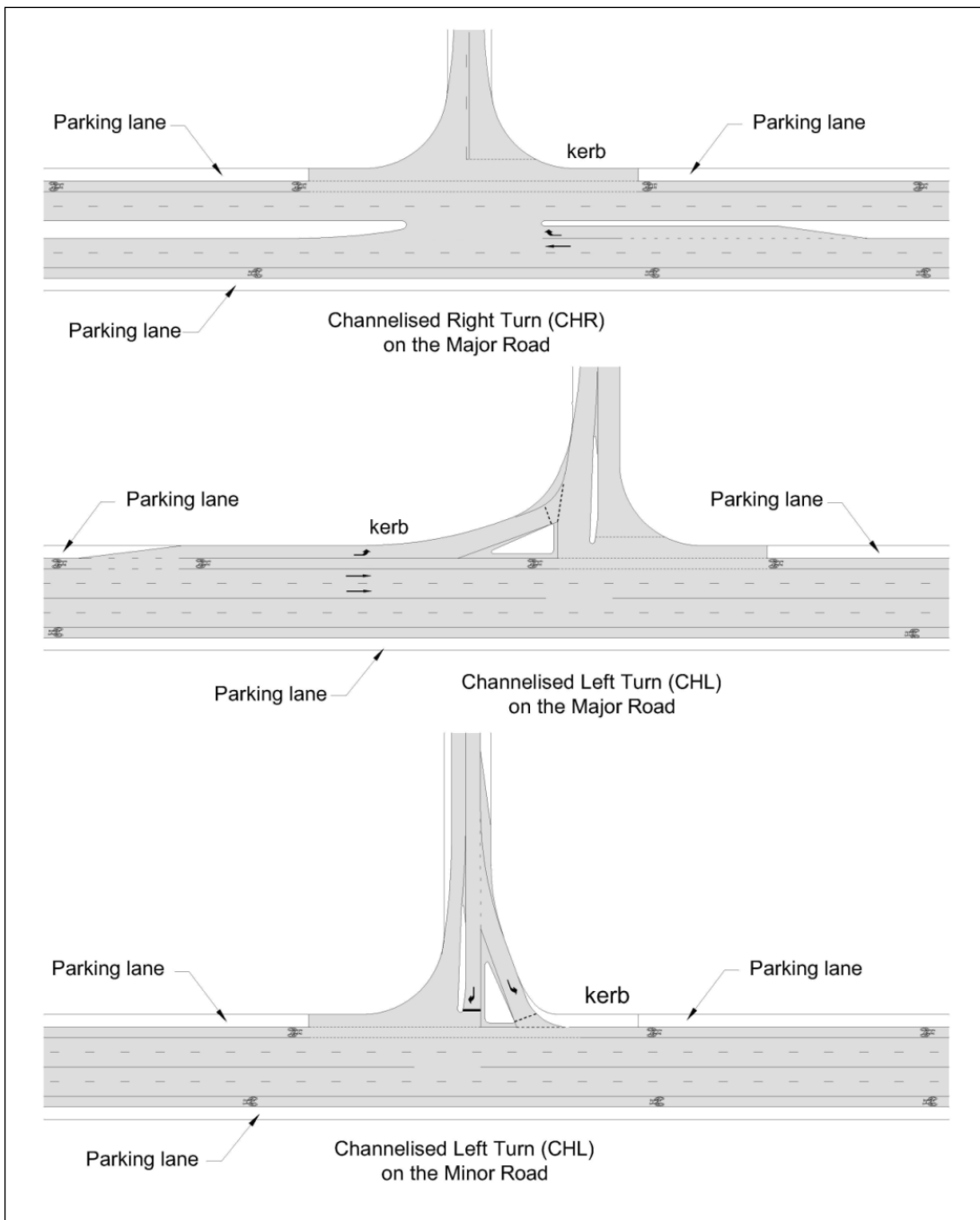

Note: Arrows indicate movements relevant to the turn type. They do not represent actual pavement markings.

Source: Austroads (2013c) Figure 2.8.

Bicycle lane treatments through intersections could also be considered at locations where cyclists would be at risk due to the geometric design requirements for motor vehicles. A short, marked bicycle lane through an intersection may provide safety advantages to cyclists provided that its termination point does not lead cyclists into an unsafe situation. Terminating at a sealed shoulder or in a wide kerbside lane would normally deliver adequate safety.

5.4.3 Channelised Left-turn Treatment

Figure 5.15 shows a bicycle lane passing through a channelised left-turn (CHL) treatment at an unsignalised intersection. The treatment may be provided to give cyclists priority through diverge areas and hence minimise conflict between cyclists and left-turning motor vehicles.

On priority cycling routes where there are long deceleration or acceleration tapers, large radius curves and high speeds, it is particularly desirable that a bicycle lane be marked through the diverge areas and merge areas. These treatments provide space for cyclists and also warn drivers of the possible presence of a cyclist.

Figure 5.15: Provision for cyclists at an unsignalised CHL treatment in a low-speed environment

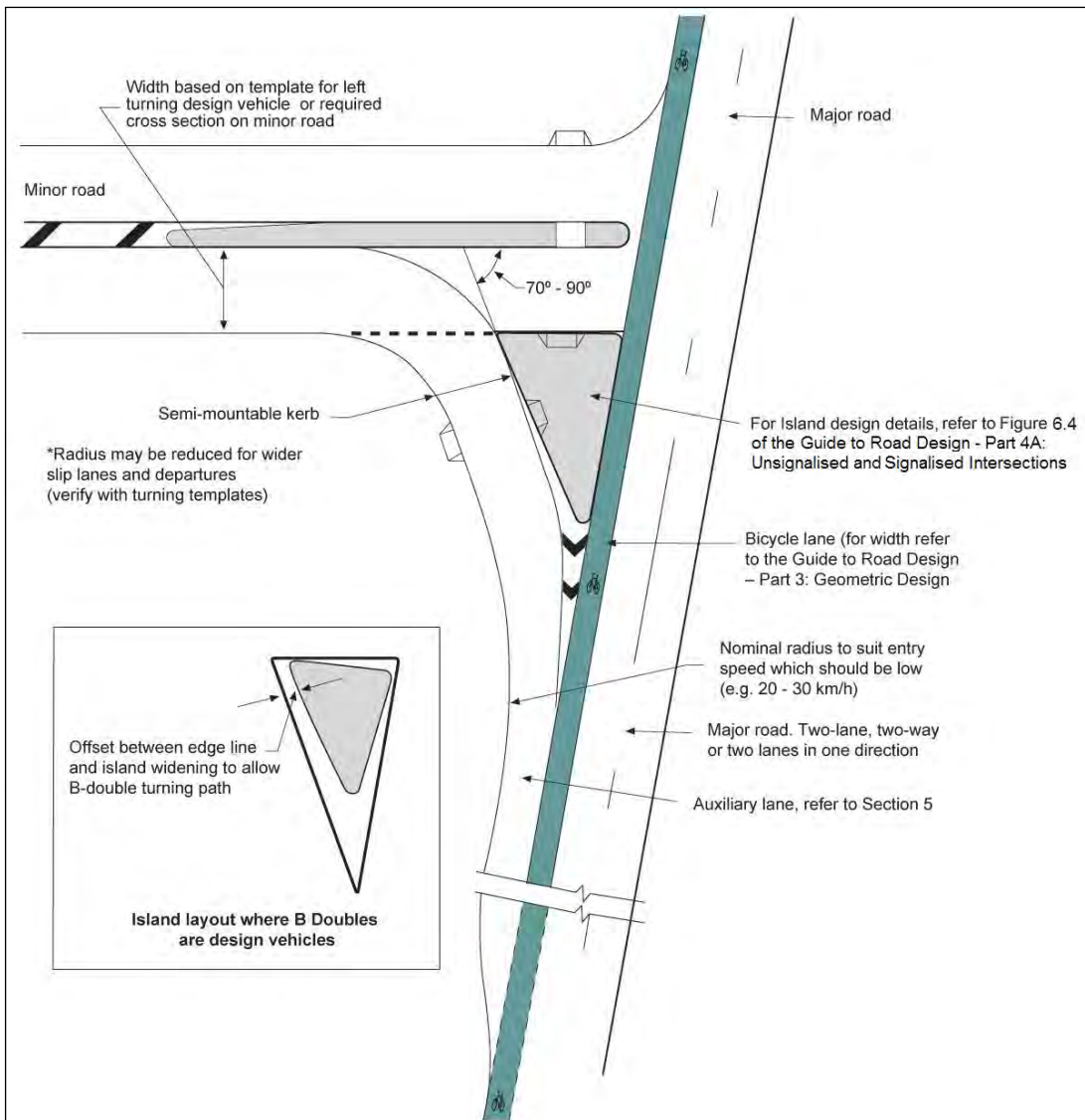

Notes:

- Bicycle lanes on priority road must be continuous through unsignalised intersections and connect to bicycle facilities on the approach and departure.
- In cases where a bicycle route turns the corner bicycle lanes may be accommodated within the minor road and within the left-turn roadway.
- Green pavement surfacing may be used where high numbers of cyclists and motor vehicles interact. Where this is not the case normal surfacing, road markings and bicycle logos may be used to delineate the bicycle lane.
- A minimum width of 5.0 m is required in the left-turn slip lane to enable vehicles to pass a disabled vehicle by mounting the semi-mountable kerb. It is therefore necessary to have a solid surface immediately behind the kerbs.

Source: Austroads (2010a) Figure 8.14.

Figure 5.16 illustrates how a bicycle lane may be designed to provide a safer treatment for cyclists through a rural channelised free-flow left-turn island treatment. A similar treatment can be used for urban free-flow left-turn channelisations.

Figure 5.16: An example of provision for cyclists at rural free-flow left-turn treatments

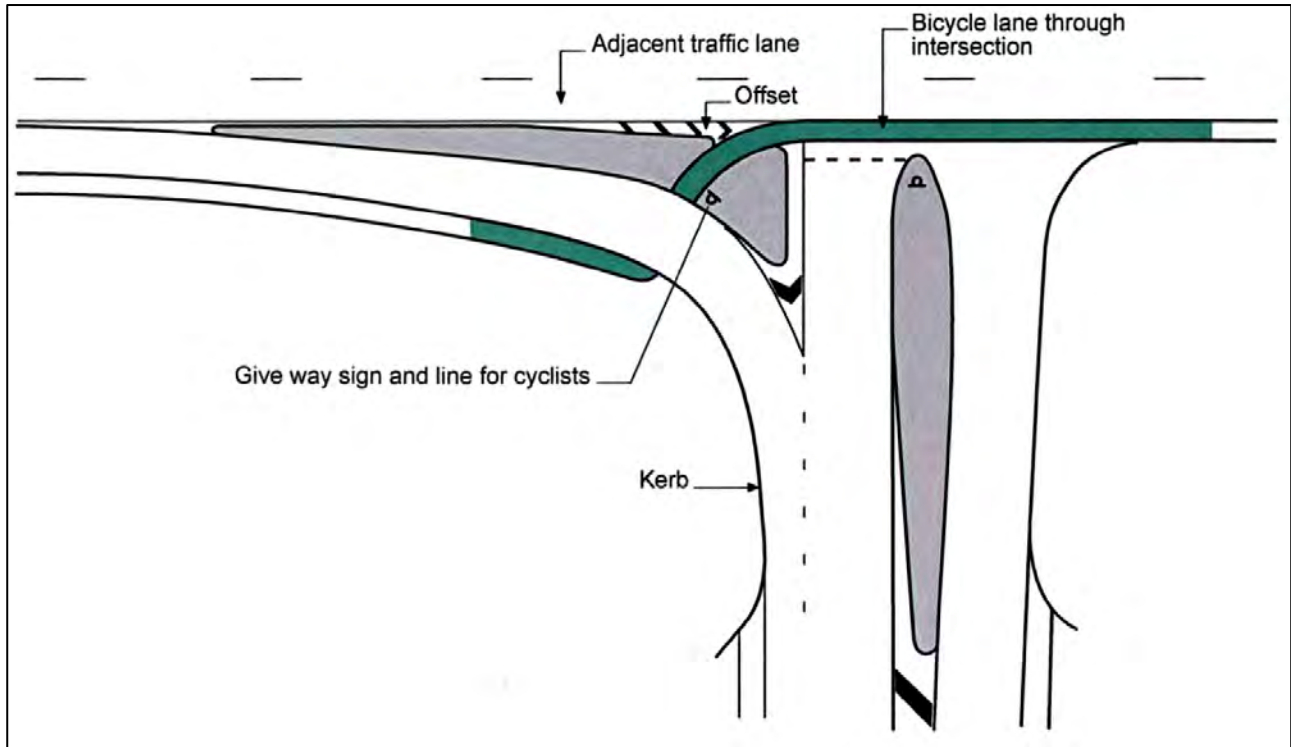

Source: Austroads (2010a) Figure 8.7.

5.4.4 Refuge within an Unsignalised Intersection

A refuge may be placed within an intersection to accommodate the crossing movements of both pedestrians from footpaths and cyclists from bicycle lanes in the side roads while restricting motorists to a 'left-turn in/left-turn out' arrangement. Such a treatment is shown in Figure 5.17.

Figure 5.17: Refuge within an intersection for pedestrians and cyclists in bicycle lanes

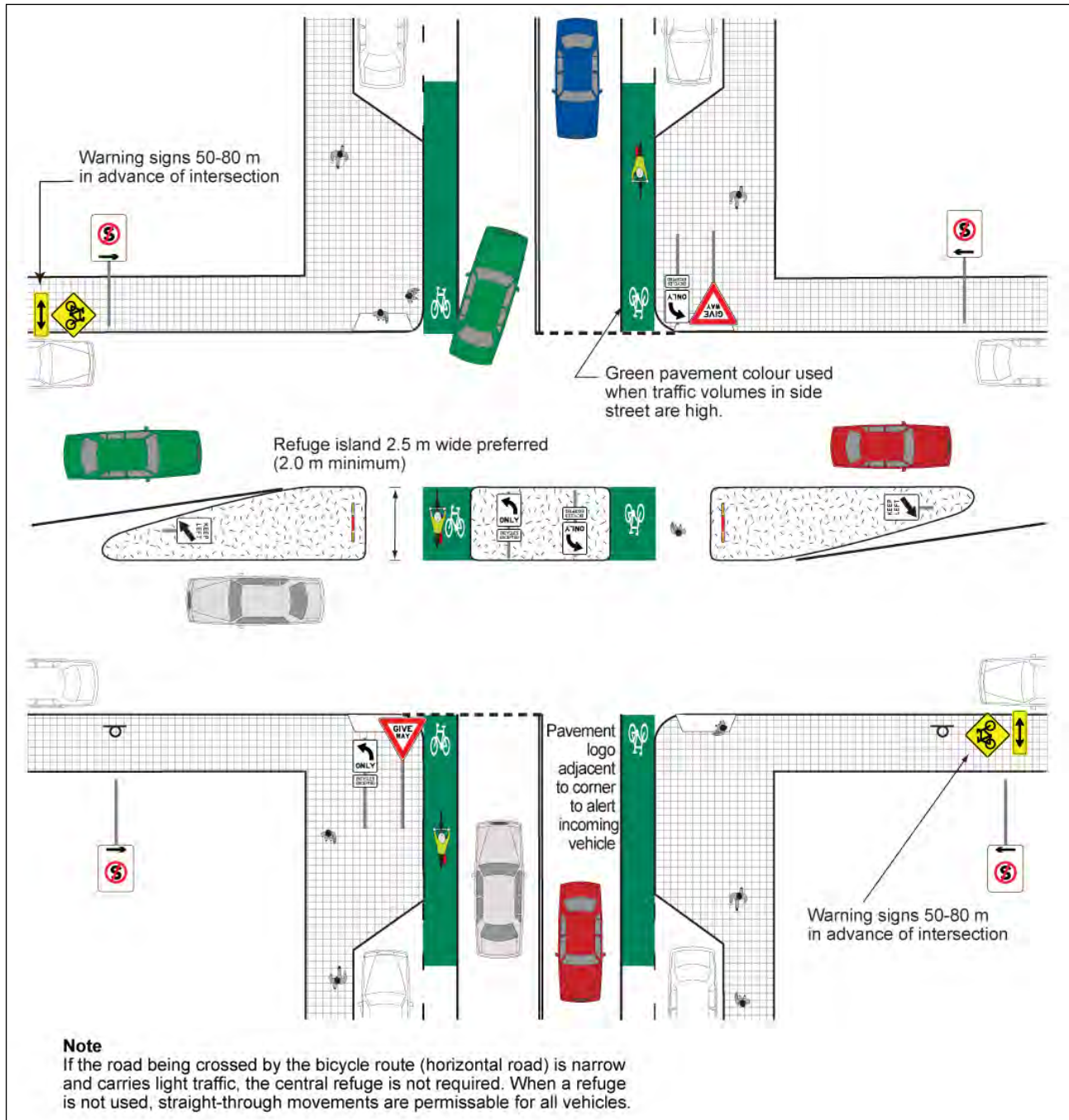

Note: If a road authority is concerned that illegal motor vehicle movements may occur through the pedestrian/cyclist slots in the refuge island, separate narrower slots may be provided for pedestrians and cyclists.

Source: Austroads (2009d) Figure 9.3, based on Roads and Traffic Authority NSW (2005).

5.5 Roundabouts

5.5.1 Introduction

Guidance on the use and design of roundabouts including bicycle treatments is provided in GRD 4B and in Section 4 of GTM 6.

Designers should strive to design roundabouts to provide an acceptable level of safety for cyclists. A number of studies have shown that roundabouts increase the risk of crashes for cyclists and this fact needs to be taken into account when considering the adoption of a roundabout treatment at an intersection. Cyclists are involved as circulating vehicles in a high percentage of entering/circulating vehicle crashes and this is likely to relate to entry speeds and motor vehicle drivers scanning behaviour on the approaches.

Where circumstances require that a significant number of cyclists use a roundabout the approaches should be designed to cater for the lowest practicable approach speed. Consideration may also be given to adopting a European alignment (refer to Figure 7 of VicRoads 2005) for the approaches whereby traffic enters at an approach angle that is approximately perpendicular to the central island (i.e. minimal flare).

Reducing the relative speed between entering and circulating vehicles, minimising the number of circulating lanes, and maximising the distance between approaches reduces the entering/circulating vehicle accident rates at roundabouts and should also minimise entering/circulating vehicle crashes involving cyclists. Therefore, the design concepts given in GRD 4B to minimise entry speeds should also minimise accidents involving cyclists.

The benefit of the treatments suggested in this section to improve the situation for cyclists at roundabouts has not necessarily been confirmed through appropriate studies. However, in the absence of such information they are generally considered to provide an advantage in that they allocate space to cyclists and/or raise motorists' awareness that cyclists may be present on the road.

The results of various studies indicate that a separated cycle path, located outside the circulating carriageway, is the safest design when there are high vehicle flows. However, on designated bicycle routes that cater for commuter cyclists consideration should be given to the provision of signalised intersections instead of roundabouts.

At small single-lane roundabouts on local streets where the geometry encourages very low approach speeds (e.g. 20 km/h) cyclists should be able to safely share the road with general traffic. At larger single-lane or multi-lane roundabouts where speeds are higher, consideration should be given to treatments that assist young or inexperienced cyclists as well as commuter cyclists, namely:

- an off-road bicycle path around the roundabout with uncontrolled cyclist/pedestrian movement across each approach leg – there is some evidence to suggest that this is the safest design, at least where traffic flows are high
- an on-road bicycle lane to improve drivers' awareness of the possible presence of cyclists and to provide some separation for cyclists from motor vehicles within the roundabout.

Where a bicycle path or shared path is provided around a roundabout, the intersection between the path and road should be designed to ensure that pedestrians and cyclists are able to safely cross the road and enter any bicycle lanes that may exist on the roundabout approaches and departures (Figure 5.27 and Figure 5.28).

A number of jurisdictions do not favour the provision of bicycle lanes on the approach to, and around the periphery of, roundabouts. Designers should clarify the policy of local jurisdictions before considering the application of cycle lanes at roundabouts. The matter is under review by the Austroads Road Design Review Panel and other key stakeholders including cycling organisations and road safety practitioners. Further advice will be issued in due course.

The extent to which special geometric treatments and/or traffic control measures are needed will depend on the:

- daily vehicle traffic volume and the peak-hour flows
- proportion of cyclists in the total traffic stream
- functional classification of the roads involved
- overall traffic management strategies for the location.

Specific provision for cyclists is not generally required at single-lane roundabouts on local streets where vehicle speeds are low (i.e. ≤ 50 km/h) and traffic volumes are low (i.e. ≤ 3000 vpd).

Conventional right-turning manoeuvres at multi-lane roundabouts are a problem for cyclists because of the nature of their interaction with motorised traffic. However, under the *Australian Road Rules* cyclists may undertake a hooked right turn. This requires cyclists to give way to traffic exiting the roundabout and therefore provision of a storage area (i.e. refuge) may be considered on the left side of exits where cyclists can wait for a gap in the exiting traffic.

Other situations where special consideration of cyclists and treatments is required to assist access and safety include:

- at roundabouts used by cyclists or where a safety problem has developed, consideration should be given to the provision of signs and/or markings to warn motorists to look for and give way to cyclists moving around the roundabout
- a path to provide a bypass of three-legged roundabouts for cyclists travelling across the top of a T-intersection (Figure 5.18)
- on approaches where provision of a left-turn slip lane on the corner of a roundabout is necessary, sometimes due to the skew of an intersection (e.g. a marked bicycle lane may be required as shown in Figure 5.19)
- where a major motor vehicle movement is able to bypass the roundabout at speed.

Figure 5.18: Roundabout at a T-intersection – path connecting bicycle lanes



Notes:

- Smooth ramps provided for cyclists to move from the bicycle lane to the path and return to the bicycle lane.
- Path provides a safer treatment across the top of the roundabout.

Source: Austroads (2011b) Figure 5.10.

Figure 5.19: Bicycle lane continuing past a left-turn slip lane at a roundabout (some jurisdictions may not favour this treatment – see previous text in this Section)



Source: Austroads (2011b) Figure 5.11.

5.5.2 Local Roads – No Bicycle Facility

Local roads provide access for cyclists across the road network. They typically comprise roads that have low traffic speeds (< 50 km/h) and relatively low volumes (< 3000 vpd). These traffic conditions generally enable cyclists to safely share the road with other traffic. Figure 5.20 shows an example of a low-volume single-lane roundabout which is based on cyclists occupying the approach lane. The approach-lane width should not exceed 3.0 m as wider lanes may encourage risky overtaking behaviour by motorists.

Figure 5.20: Bicycle route through a single-lane roundabout – no bicycle facility

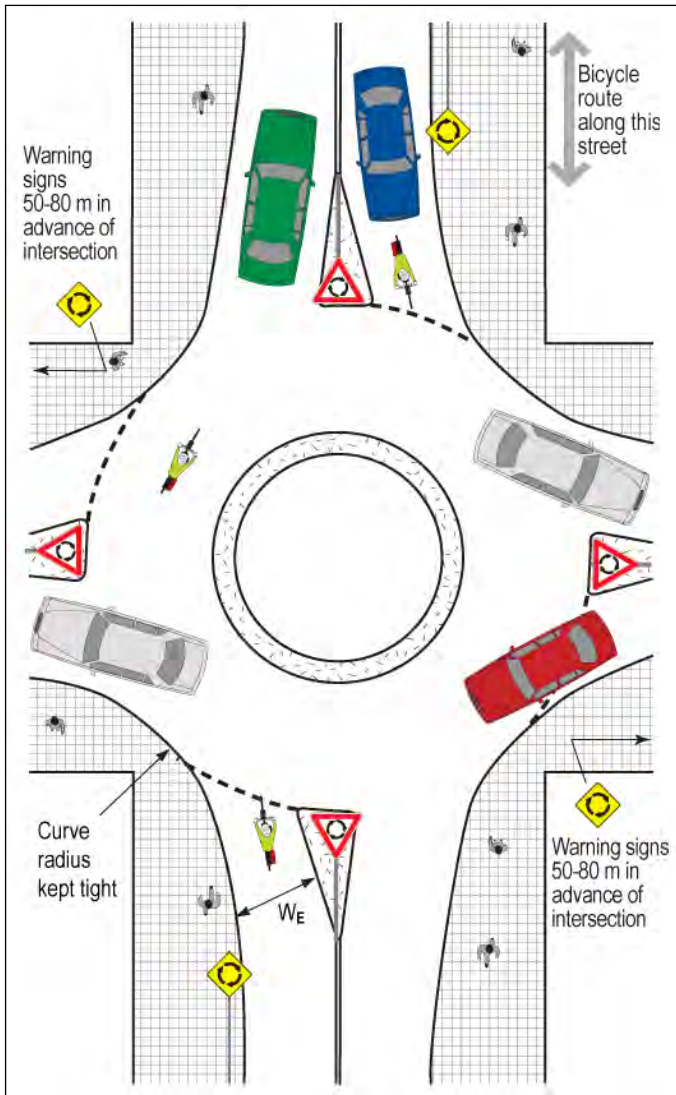

Note: The width of the entry W_E should cater for the design vehicle (e.g. service vehicle or fire truck). However, it is preferable that W_E is less than 3.0 m so that drivers do not attempt to enter the roundabout alongside cyclists and 'squeeze' them into the kerb.

Source: Austroads (2011b) Figure 5.1, based on Roads and Traffic Authority NSW (2005).

5.5.3 Bicycle Lanes at Single-lane Roundabouts

Local street with bicycle lanes

Figure 5.21 shows a treatment that is suitable for bicycle routes at local street intersections that have low approach speeds and low volumes. It provides warning signs and bicycle lanes on the approaches but no special treatment within the circulating roadway. The bicycle lanes must extend to the holding lines so that a squeeze point for cyclists is not created. The low volume of heavy vehicles on this type of road means that the road can be shared with cyclists. Cyclists typically turn right with general traffic.

Figure 5.21: Bicycle lane at a small single-lane roundabout on a local road (some jurisdictions may not favour this treatment – see Section 5.5.1)

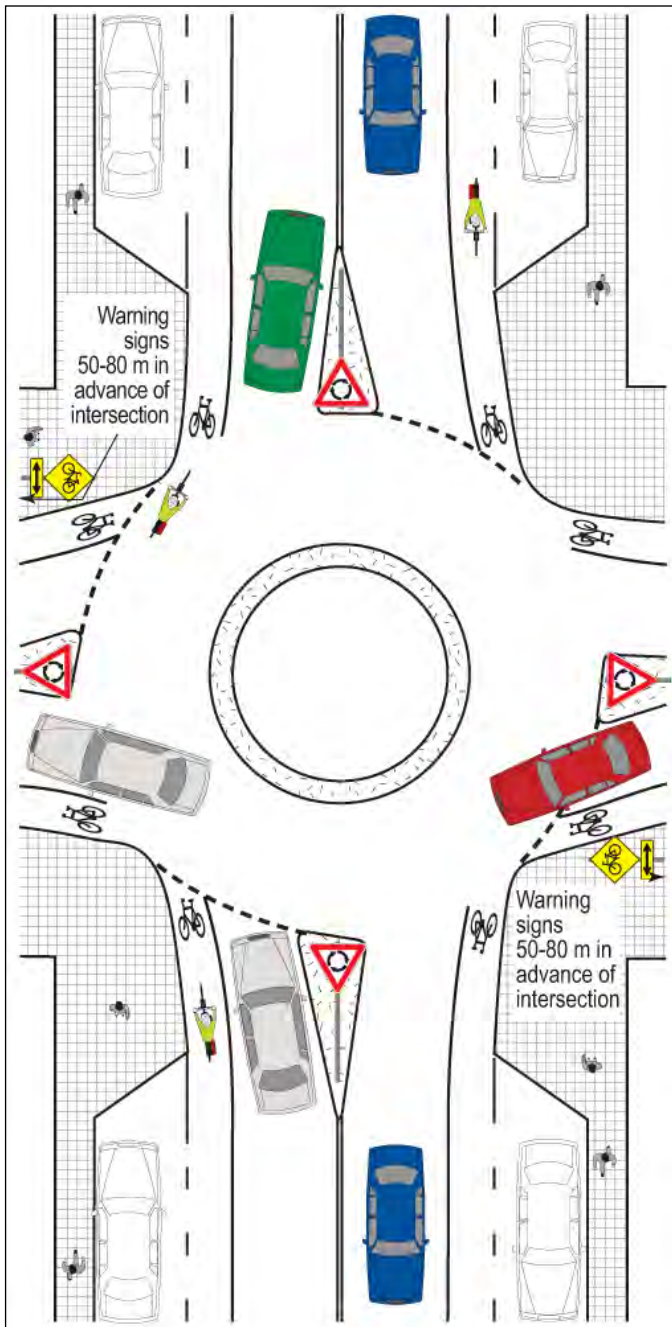

Source: Austroads (2011b) Figure 5.2, based on Roads and Traffic Authority NSW (2005).

Collector road or arterial road with physical separation of bicycle lanes

Where bicycle routes pass through single-lane roundabouts that have relatively high traffic volumes and moderate speeds, a marked bicycle lane may be provided within the roundabout as shown in Figure 5.22. The circulating bicycle lane should have a contrasting surface that provides cyclists with separate space and comfort but no special priority. However, advance warning signs, a contrasting surface and bicycle pavement logos should be provided to ensure that the facility is highly visible and warns motorists of the likely presence of cyclists. Cyclists passing straight through the roundabout or turning left will remain in the bicycle lane. Cyclists may turn right with general traffic or undertake a hook turn from the left side of the exit. As the islands separating cyclists from motor vehicles are narrow, it is most important that they are provided with a high standard of delineation (e.g. narrow retro-reflective signs on all noses facing traffic approaching the roundabout and departing from the roundabout).

Figure 5.22: Two bicycle routes crossing at a single-lane roundabout with physically separated bicycle lanes (some jurisdictions may not favour this treatment – see Section 5.5.1)

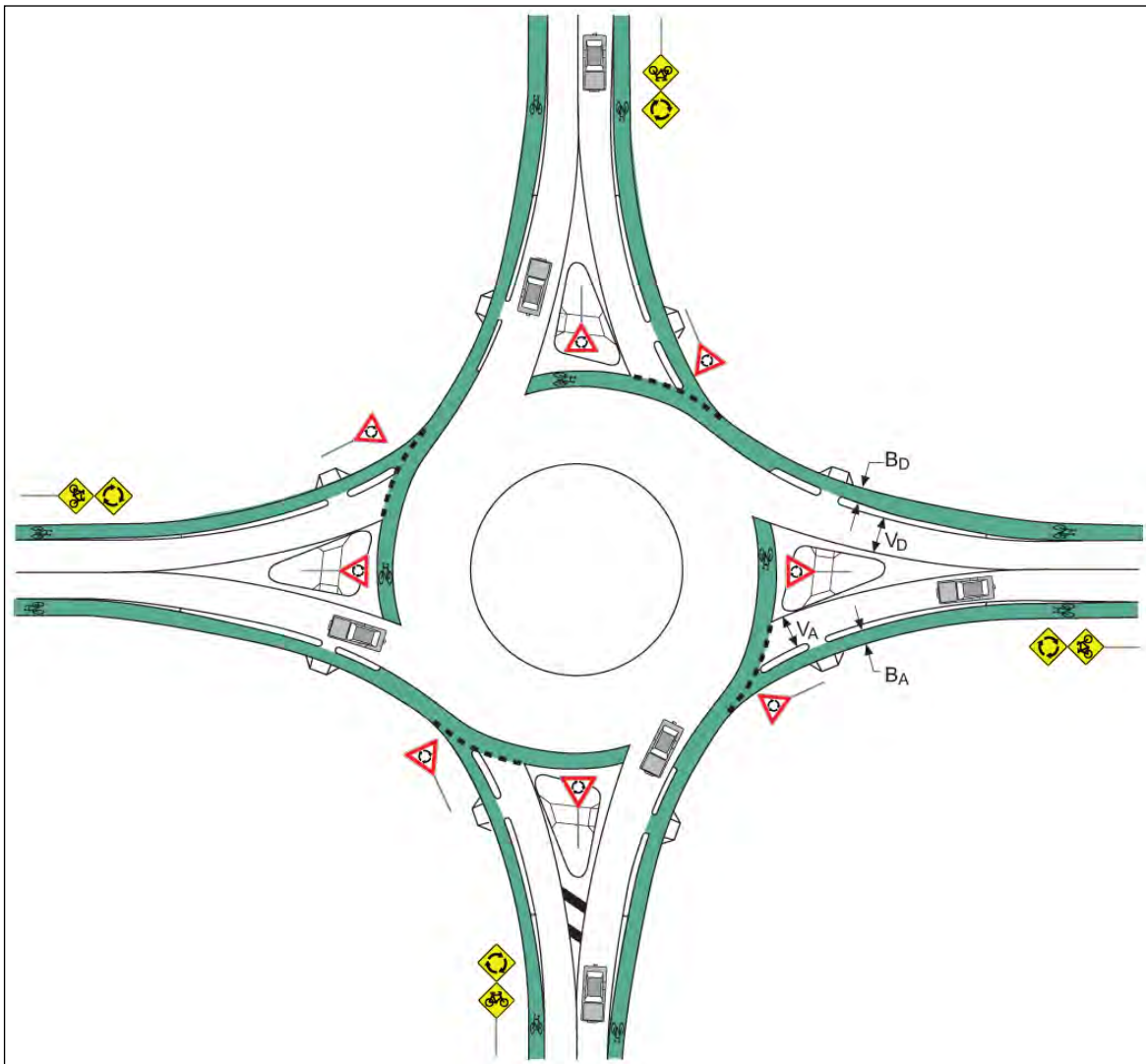

Notes:

- $BD = 1.5\text{ m}$; $BA = 1.25\text{ m}$; VA = entry width to suit design vehicle; VD = exit width to suit design vehicle.
- Holding line to extend across entire entry including bicycle lane.

Source: Based on Roads and Traffic Authority NSW (2005).

Collector road or arterial road with no physical separation of bicycle lanes

The treatment shown in Figure 5.23 has been adopted and implemented by some road authorities. It provides a bicycle lane on the roundabout approaches and departures without any physical separation. It is known that many motorists will cut across the bicycle lane on the entry and exit curves when no cyclists are present. For this reason, the maximum entry path radius criteria should be applied by assuming drivers will cut across the bicycle lane.

There is some concern that this treatment may lead to conflict between heavy vehicles and bicycles where the route carries a relatively high volume of both freight vehicles and cyclists. It is therefore suggested that the entries of these treatments should be designed so that the swept paths of entering design vehicles do not have to encroach into the bicycle lane. However, where a site has low volumes of both trucks and bicycles, encroachment may be allowed if necessary to achieve the maximum entry radius criteria.

Figure 5.23: Two bicycle routes crossing at a single-lane roundabout with no physical separation of bicycle lanes (some jurisdictions may not favour this treatment – see Section 5.5.1)

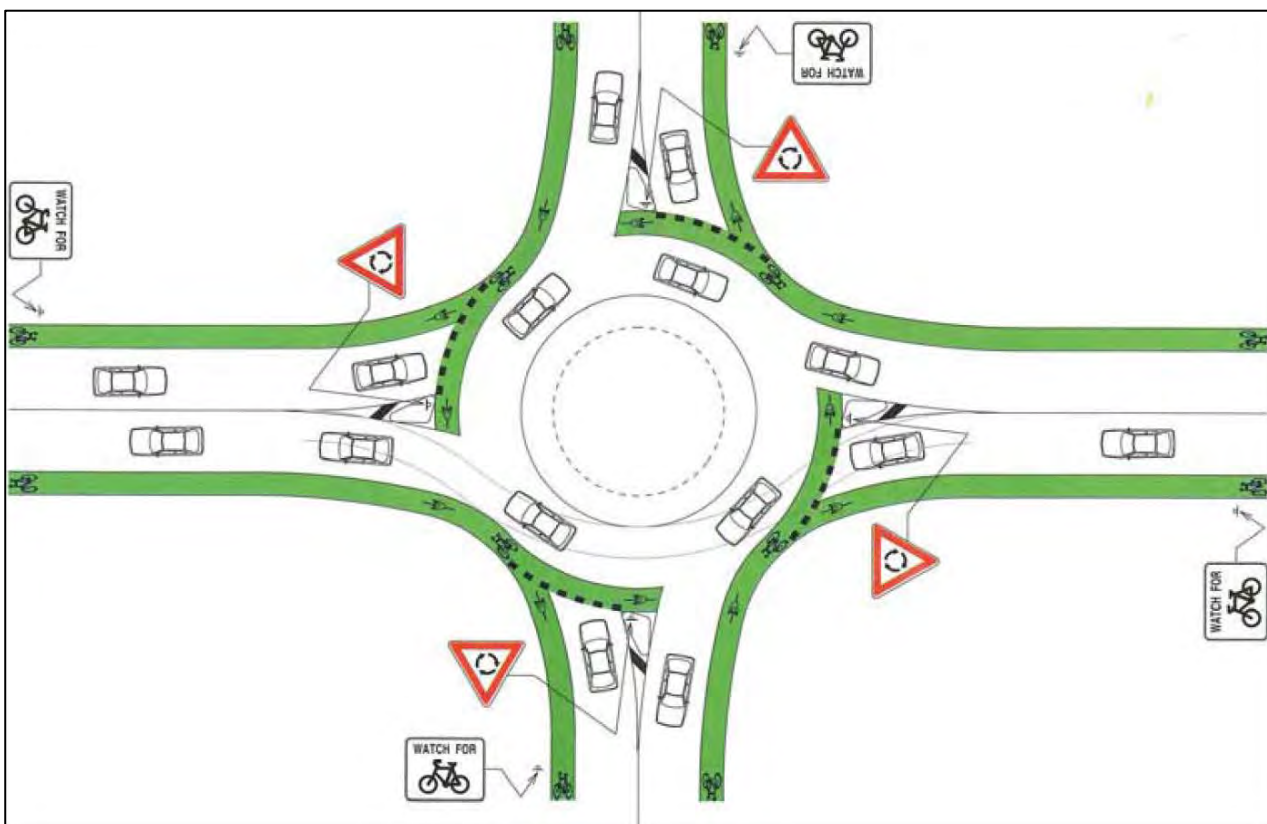

Source: Austroads (2011b) Figure 5.4, based on VicRoads (2005).

5.5.4 Multi-lane Roundabouts on Arterial Roads

Multi-lane roundabouts usually carry high traffic volumes and have higher entry speeds than local street roundabouts and therefore create safety problems for cyclists. It is anticipated that only experienced cyclists will use this type of roundabout and whilst they may feel reasonably comfortable in selecting a gap and turning left and travelling straight through a multi-lane roundabout in the bicycle lane, they will generally find the right-turning manoeuvre challenging. Some cyclists will therefore bypass the right turn by using local streets, shared paths at the roundabout (where provided) or by undertaking a hook turn at the exit.

There is currently no treatment that would assist cyclists to turn right safely through a multi-lane roundabout. However, the provision of bicycle lanes within multi-lane arterial road roundabouts is considered to offer some advantages to cyclists in that these lanes:

- heighten the awareness of motorists approaching the roundabout that cyclists may be present
- provide designated space on the circulating carriageway and thereby assist experienced cyclists to negotiate the through movement
- assist cyclists to undertake a hook turn (right turn) as described in the *Australian Road Rules*.

Some jurisdictions may prefer not to provide the islands between the bicycle lane and the adjacent traffic lanes at multi-lane roundabouts. Where a multi-lane roundabout carries high volumes of both heavy vehicles and bicycles it is recommended that the bicycle lane should be physically separated from the general traffic lanes on the approaches as illustrated in Figure 5.24. Designers should design the island in accordance with the normal design principles for traffic islands (Section 10, GRD 4). Figure 5.25 and Figure 5.26 show suggested details of the separation islands which are similar in principle to a pedestrian and cyclist refuge island.

Figure 5.24: Bicycle lanes at a two-lane roundabout with physical separation for cyclists (some jurisdictions may not favour this treatment – see Section 5.5.1)

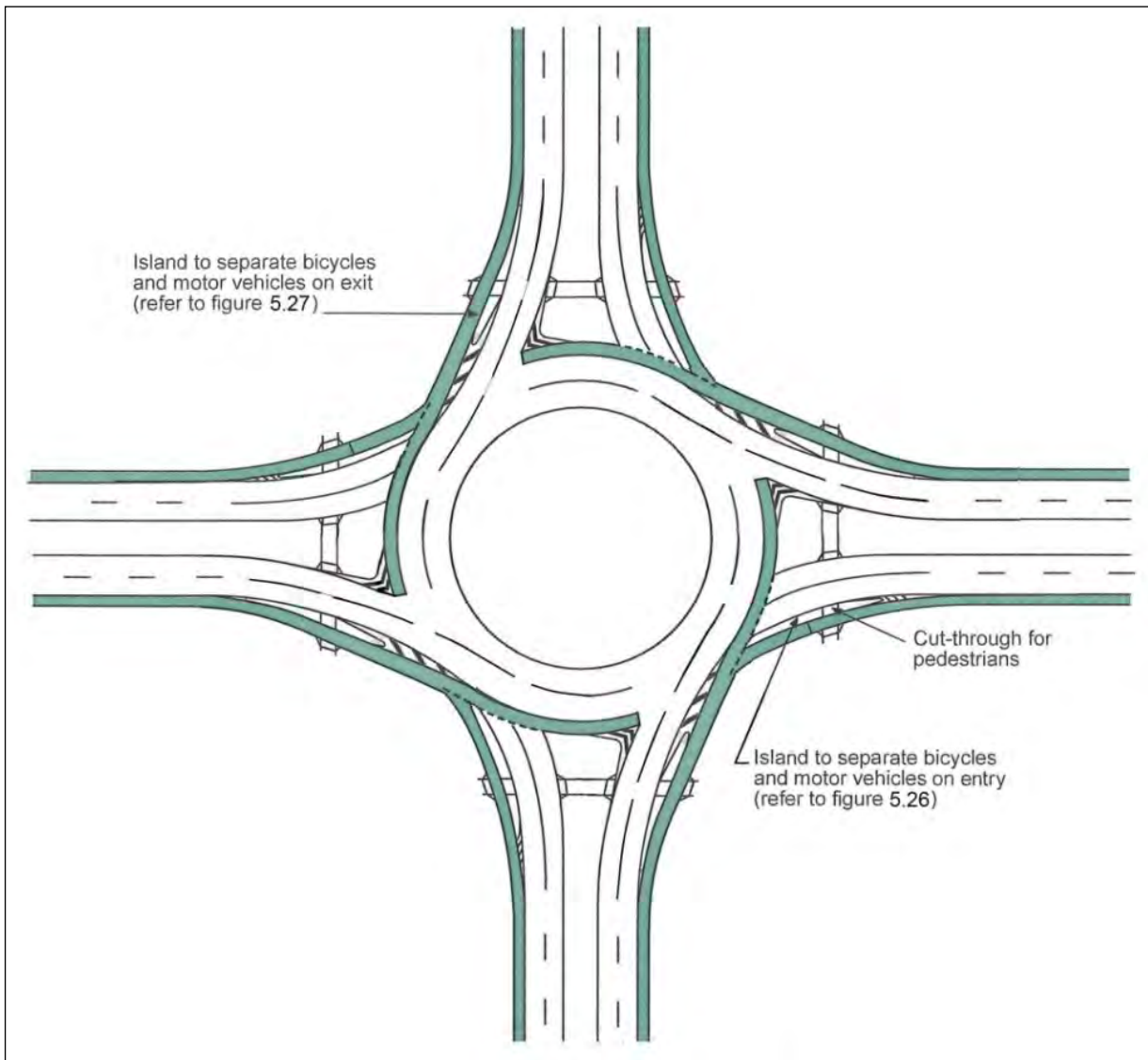

Source: Austroads (2011b) Figure 5.5.

Figure 5.25: Details of an island on a multi-lane roundabout entry to separate cyclists and motorists (some jurisdictions may not favour this treatment – see Section 5.5.1)

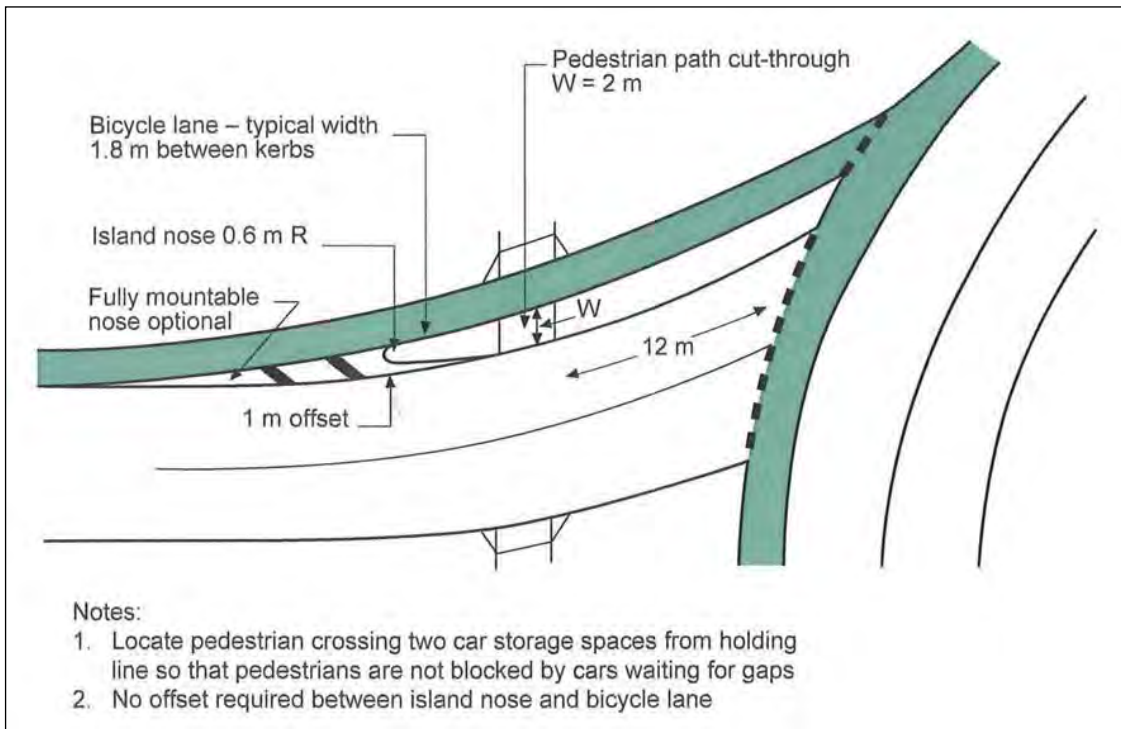

Source: Austroads (2011b) Figure 5.6.

Figure 5.26: Details of an island on a multi-lane roundabout exit to separate cyclists and motorists (some jurisdictions may not favour this treatment – see Section 5.5.1)

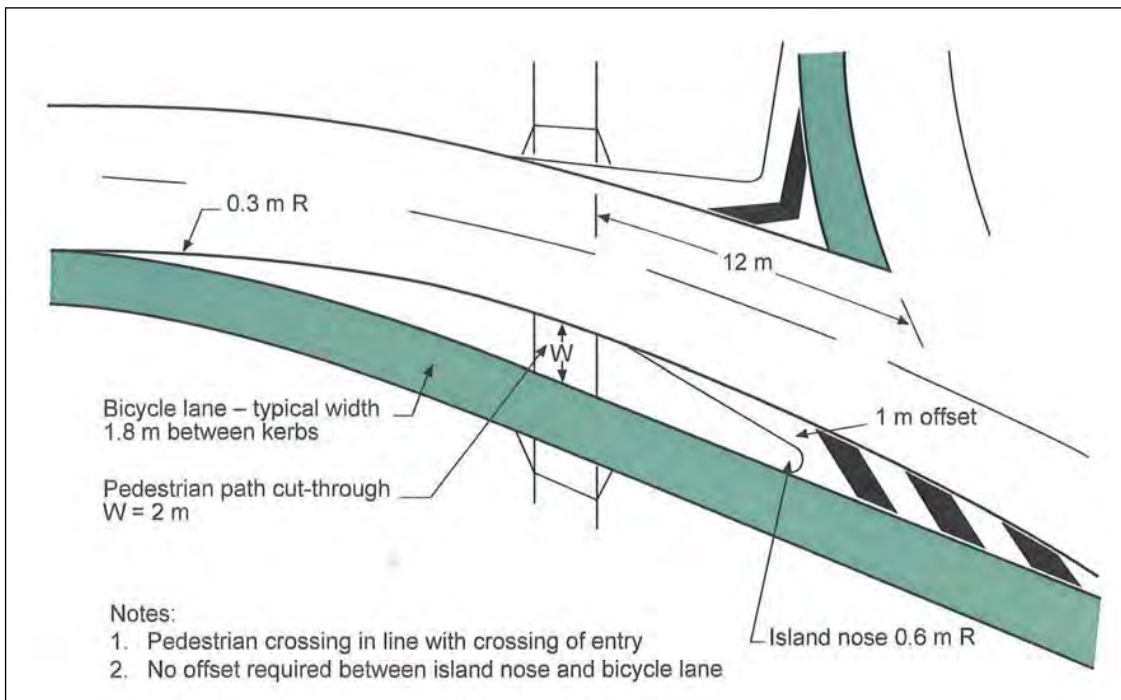

Source: Austroads (2011b) Figure 5.7.

5.5.5 Bicycle Paths and Shared Paths at Roundabouts

Bicycle paths or shared paths may be provided adjacent to roundabouts to provide safer passage for inexperienced cyclists and pedestrians. At sites where there is a relatively small volume of pedestrians and cyclists the treatment in Figure 5.27 with normal kerb ramps will suffice.

Figure 5.27: Path at a roundabout where cyclist and pedestrian volumes are low to moderate

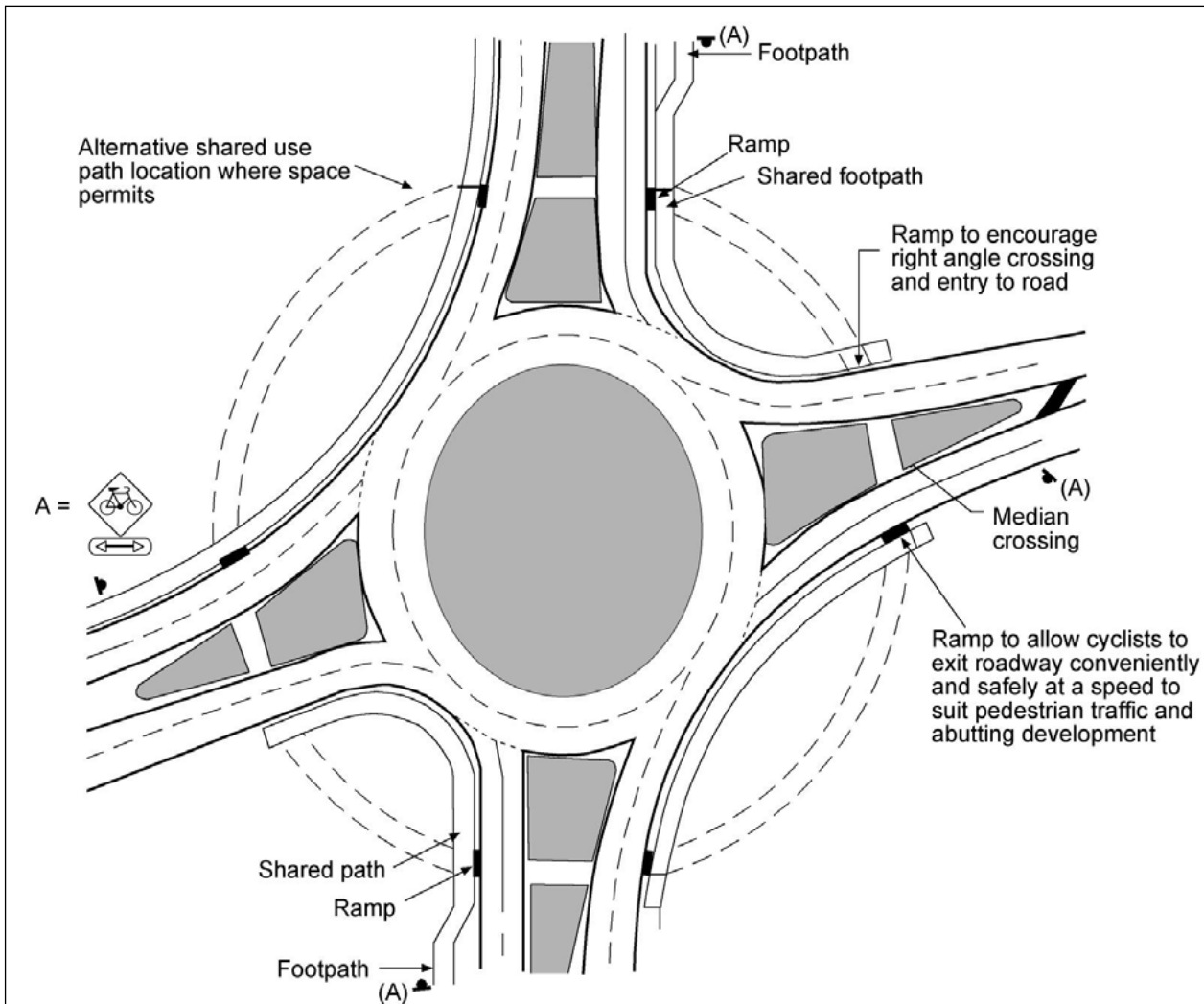

Source: Austroads (2011b) Figure 4.6.

Where a shared path is provided at a multi-lane roundabout and bicycle lanes exist on the approach, the crossing treatment shown in Figure 5.28 may be used. This treatment provides a crossing at road level as well as convenient connections between the bicycle lanes and the paths to encourage cyclists to use the shared path to negotiate the roundabout. It is also possible to modify this treatment so that the bicycle lane passes through the roundabout, thereby providing an option for cyclists to remain on the road or to utilise the shared path and road crossings. The treatment in Figure 5.28 also suggests that cyclists using the shared path crossings should be controlled by give-way signs.

Figure 5.28: Crossing detail for a shared path adjacent to a multi-lane roundabout

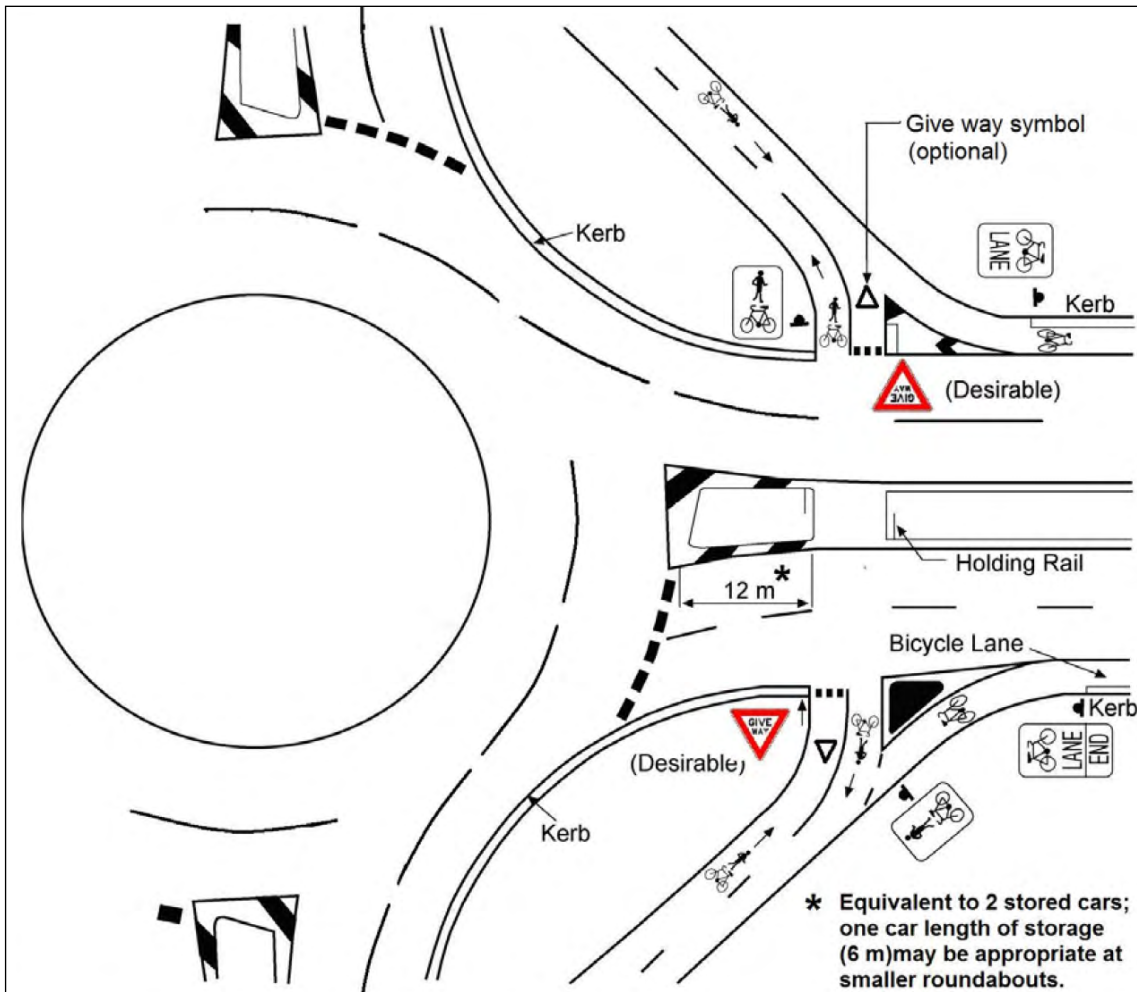

Source: Austroads (2011b) Figure 4.8, based on VicRoads (2005).

5.6 Road Interchanges

5.6.1 General

Issues and the general provisions for cyclists on freeways are covered in Section 4.8. This section provides some further information on options for dealing with cyclist movements at road interchanges (GTM 6).

Where cyclists are permitted to travel on roads that have interchanges (freeways, motorways or arterial roads), they should be provided with safer and convenient facilities, such as wide shoulders that have smooth, clean surfaces suitable for cycling.

Cyclist access may be denied to freeways or motorways due to:

- the difficulties and safety risks associated with high-speed and high-volume traffic environments
- geometric features that are not conducive to safer cycling (e.g. narrow shoulders)
- use of shoulders for other purposes (e.g. public transport).

There is inherent danger associated with cyclists attempting to cross high-volume ramps at the nose (even if directed to use other routes), particularly two-lane exits.

It is important that the interchange design provides continuity of the bicycle route through the interchange and for safer and convenient movement of cyclists across ramps and the intersecting arterial road.

5.6.2 At-grade Treatment at Interchanges

At interchanges, the route to be provided for cyclists should be established and clearly signed. Cyclists should only be permitted to pass through interchanges via at-grade crossings of ramps where sufficient gaps exist in traffic flows to enable cyclists to cross the ramps. For additional guidance refer to Section 14 of GRD 4C.

Where cyclists are permitted to pass through an interchange using at-grade crossings of ramps the desirable route should be clearly marked and signed as shown in Figure 5.29.

In order for cyclists to be able to cross a ramp at the nose, the volume and approach pattern of motor vehicles using the ramp must be such that adequate gaps occur in the traffic stream to enable a safer and convenient crossing of the ramp to be made by cyclists. This method requires a cyclist to turn from the shoulder/breakdown lane and cross the ramp at right-angles.

It is estimated that a cyclist requires a gap of seven seconds in order to cross the ramp (Ove Arup & Partners 1989). This gap was determined using the assumption that both the bicycle length and the car width are 2.0 metres. Assuming that the speed of the bicycle is 5 km/h (1.4 metres per second), at the crossing it will take almost three seconds for the bicycle to pass in front of the motor vehicle. If it is further assumed that at least two seconds clearance is required after the passage of the first vehicle and also before passage of the second vehicle it follows that a minimum gap of seven seconds is required.

If the ramp is an off-ramp or the on-ramp is not controlled by traffic signals it may be reasonable to assume that vehicles using the ramp arrive at random and gap acceptance theory should be used to estimate the delay likely to be suffered by cyclists in crossing these ramps. If analysis indicates that the average delay to a cyclist is greater than 15 seconds (beyond which they are assumed to accept gaps of greater risk, i.e. less than seven seconds), then cyclists should be directed to use the exit ramp, cross the intersecting road at-grade, and re-enter the freeway via the on-ramp, or a grade separation of the ramp for cyclists should be evaluated. If an on-ramp is controlled by traffic signals then the ability of cyclists to cross the ramp must be evaluated in relation to the signal cycle and phasing and other traffic movements which may not be controlled by signals.

Figure 5.29: Typical at-grade treatment for cyclists at exit and entry ramps

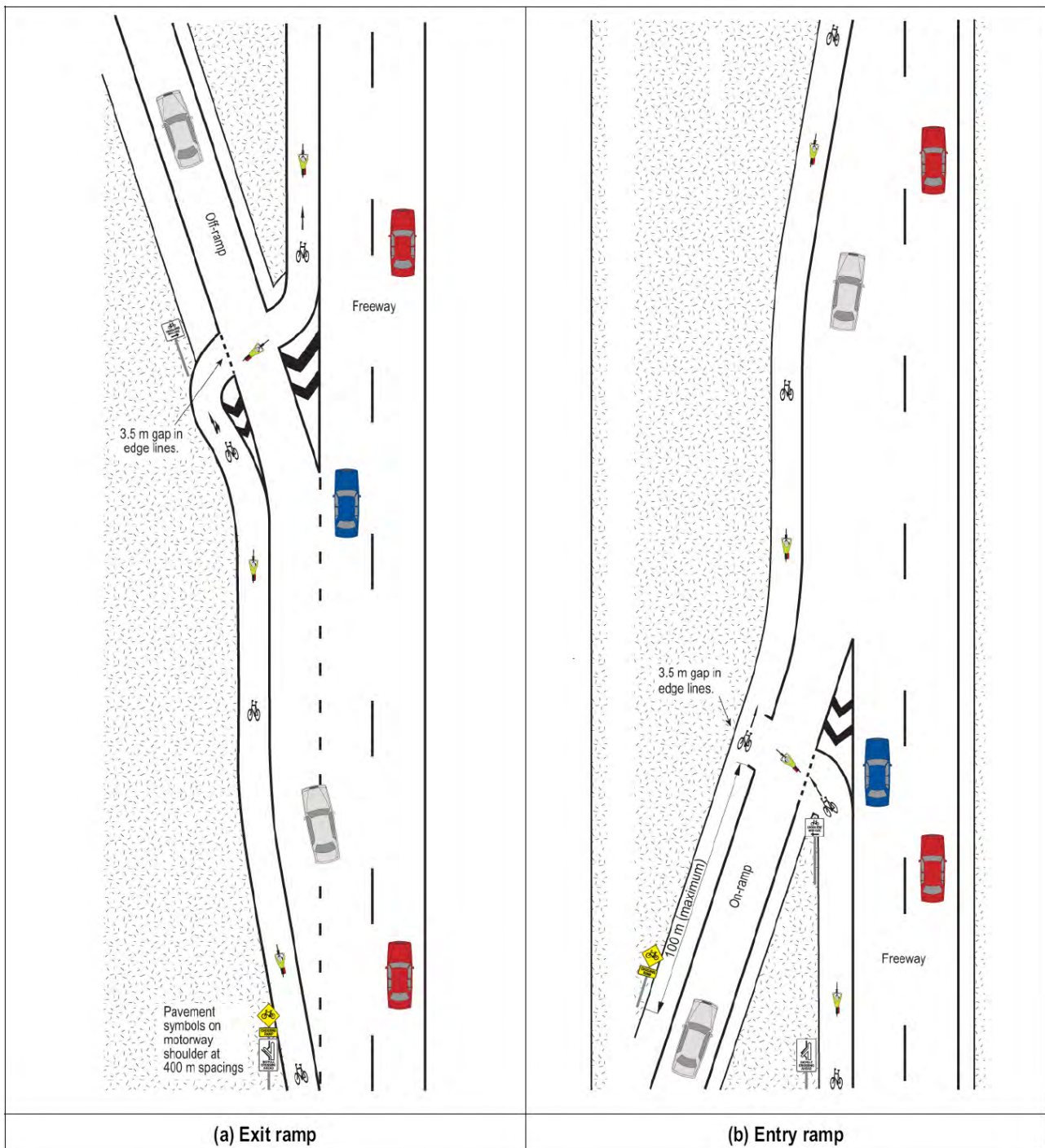

Source: Austroads (2009e) Figure 14.2, based on Roads and Traffic Authority NSW (2005).

5.6.3 Grade Separation of Ramps for Cyclists

Grade separation of cyclist movements across exit and entry ramps should be considered where large flows of cyclists use a freeway or a major path associated with a freeway. At such levels of flow it may be more appropriate to provide a high-speed exclusive bicycle path within the freeway reservation with grade separations at the minor roads. Even if cyclists continued to use the freeway shoulders it may be more viable and practical to require them to use the freeway ramps, and provide an underpass of the minor road, for example.

5.6.4 Alternative Routes

Where there are unacceptable risks for cyclists to use a freeway and there is insufficient space for a cycling facility, alternative routes providing a similar level of service should be defined and developed off the freeway. These routes may comprise:

- routes on the surface arterial road network or local street network
- a bicycle path or shared path within the freeway reservation with either at-grade crossings of the minor road at ramp terminals, or grade separation of the minor road (refer to GRD 6A).





Alternative routes should provide the highest practicable level of service for cyclists (e.g. minimise stops, most direct route, separation from motor vehicles etc.).

6. Provision for Cycling at Rail Crossings

6.1 General

Traffic management aspects and layout arrangements for pedestrian and bicycle crossings of railways are covered in GTM 6, AS 1742.7-2007 and the *Manual of traffic signs and markings* (MOTSAM, NZ Transport Agency 2010a and 2010b). Cross-references to the sections of Austroads Guides related to cyclists at rail crossings are shown in Table 6.1.

Table 6.1: Key cross-references related to cyclists at rail crossings

Section of <i>Cycling Aspects of Austroads Guides</i>					
Guide	Section	Reference source	Guide	Section	Reference source
Section 6.2: Types of Rail Crossings					
	Section 7.2	Austroads (2013c)		Section 10	Austroads (2009d)
Section 6.3: Key Requirements and Considerations					
	Sections 7.2	Austroads (2013c)			
Section 6.4: Path Crossings					
	Section 7.6	Austroads (2013c)			

Notes:



Guide to Road Design (GRD)



Guide to Traffic Management (GTM)

6.2 Types of Rail Crossings

Traffic control of at-grade rail crossings may be achieved through the use of passive or active traffic control devices. Paths may utilise at-grade level crossings or be grade separated.

Active protection (or active control) is the control of the movement of vehicular or pedestrian traffic across a railway crossing by devices such as flashing lights, gates or barriers (also half-arm barriers in NZ), or a combination of these, where the device is activated prior to and during the passage of a train through the crossing.

Passive protection (or passive control) is the control of the movement of vehicular or pedestrian traffic across a railway crossing by signs and devices, none of which are activated during the approach or passage of a train, and which relies on the road user, including pedestrians, detecting the approach or presence of a train by direct observation.

6.3 Key Requirements and Considerations

Key requirements are that the crossing should have a smooth and straight alignment, preferably at right angles to the rails, with a well-maintained interface between the path and rails, and the appropriate traffic control devices to warn, regulate, advise and control pedestrians (including people who have impairments) and cyclists.

6.3.1 On-road Railway Level Crossings

Key considerations for different types of railway crossings are shown in Table 6.2.

Table 6.2: Considerations for pedestrians and cyclists at railway crossings

Type of railway crossing	Considerations for pedestrians and cyclists
Passive controlled at-grade crossings	<ul style="list-style-type: none"> ▪ Provide signs to warn pedestrians and cyclists to look for trains; pavement markings to define footway and safer waiting position. ▪ Where cyclists are permitted to ride over the crossing, provide a cyclist warning sign on approaches to the crossing. ▪ Where cyclists are not permitted to ride over the crossing, provide <i>cyclist must dismount signs</i> on the approaches to the crossing. ▪ Ensure surface condition is adequate including flangeway gaps (within practicable limitations). ▪ Where necessary (e.g. urban areas) provide pedestrian mazes or gated enclosures; where mazes are provided, people with visual or mobility impairments, or people pushing prams should be able to easily negotiate them. ▪ Requirements also apply to pedestrian crossings remote from vehicular crossings.
Active controlled at-grade crossing	<ul style="list-style-type: none"> ▪ Provide red symbolic standing pedestrian signals, audible alarms and signs to warn pedestrians and cyclists to look for trains. Also use pavement markings to define the footway and a safer waiting position. ▪ Where cyclists are permitted to ride over the crossing, provide a cyclist warning sign on approaches to the crossing. ▪ Where cyclists are not permitted to ride over the crossing, provide 'Cyclist must dismount' signs on the approaches to the crossing. ▪ Ensure surface condition is adequate including flangeway gaps (within practicable limitations). ▪ Where necessary (e.g. urban areas) provide pedestrian mazes or gated pedestrian enclosures; where gated enclosures and mazes are provided, people with impairments or people pushing prams should be able to easily negotiate them. ▪ Requirements also apply to pedestrian crossings remote from vehicular crossings.

Source: Austroads (2013c) Tables 7.1 and 7.2.

6.4 Path Crossings

The type of path provided on a road approach to a rail level crossing is a matter for the relevant road authority. Key requirements are that the path crossing should have a smooth and straight alignment, preferably at right angles to the rails, with a well-maintained interface between the path and rails, and the appropriate traffic control devices to warn, regulate, and to advise and control cyclists. Railway crossings should comply with AS 1742.7-2007 or MOTSAM (NZ Transport Agency 2010a and 2010b).

AS 1742.7-2007:

- States that a 'Cyclists dismount' sign shall be used at crossings that are primarily used by pedestrians i.e. that are not part of a shared path, but may be used by cyclists. This requirement is intended to emphasise to cyclists that it is safer for both pedestrians and cyclists if they dismount and consequently they must not ride on the crossing.
- Includes an informative appendix of typical examples of pedestrian facilities at rail level crossings. The treatments include a minimum treatment, mazes, and gate enclosures. Treatments with passive and active control are illustrated. The 'Cyclist dismount' sign is shown in Figure 6.1.
- Does not provide warrants or guidelines to determine whether pedestrian or cyclist facilities are to be provided and, if so, which treatment is to be used. Road and rail authorities should work together to develop warrants taking into account pedestrian and cyclist volumes, train movement patterns, whether active control is provided for vehicular traffic and any other relevant risk factors.

Figure 6.1: Examples of signs used at pedestrian and cyclist crossings of railways

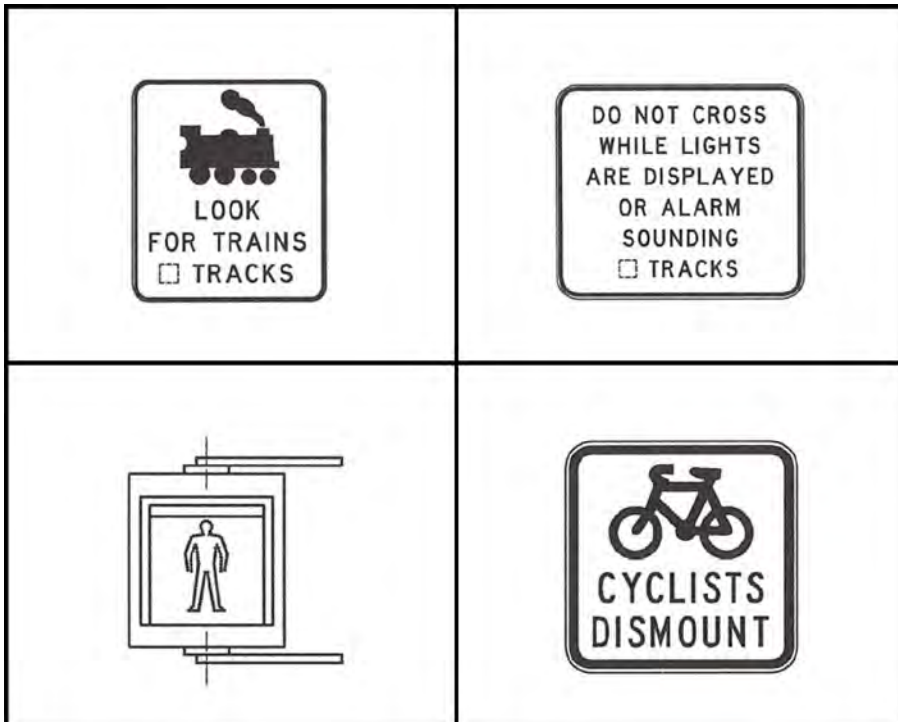

Source: Austroads (2013c) Figure 7.5 and AS 1742.7-2007.

6.4.1 Grade Separation for Paths

In situations where a grade separation of a railway crossing forms part of a shared path, the structure must be designed to a standard that is adequate for combined use by cyclists and pedestrians, including wheelchair users and people pushing prams. In particular:

- overpasses and underpasses should have an adequate width
- adequate vertical clearance is essential
- adequate sight distance must be available (particularly relevant to the entries and exits of underpasses)
- higher railings, designed not to snag bicycle pedals, are required on overpasses
- suitable gradients must be provided.

7. Paths for Cycling

7.1 General

The design of bicycle paths is comprehensively covered in GRD 6A. Designers and practitioners are therefore referred to that Guide.

Section 2 of GRD 6A summarises the key objectives of the Australian and New Zealand cycling strategies and emphasises the important contribution cycling can make to the well-being and transportation of people.

From a traffic management perspective (refer to GTM 5) off-road bicycle facilities may be provided for the:

- safety of inexperienced, young and aged cyclists
- health and enjoyment of recreational cyclists
- convenience of commuter cyclists (e.g. high-speed exclusive bicycle path, shared path immediately adjacent to an arterial road to bypass a difficult section for cyclists).

Consequently paths may be provided for utility and commuter use, recreational use or a combination of these uses.





Cross-references to the guidance referred to in this section are summarised in Table 7.1.

7.2 Types of Path

The types of path commonly used (GTM 5, Table 3.2,) are:

- Shared paths that may be appropriate where:
 - demand exists for both a pedestrian path and a bicycle path but where the intensity of use is not expected to be sufficiently great to provide separate facilities
 - an existing low-use path can be satisfactorily modified (e.g. by appropriate width and signage) to provide for cyclists.
- Exclusive bicycle paths that are set aside for cyclists and may be appropriate where:
 - there is a significant cycling demand and very few pedestrians desire to use the path or a separate pedestrian path is provided
 - there is very limited motor vehicle access across the path
 - it is possible to achieve an alignment that allows cyclists uninterrupted and safe travel at a relatively high constant speed (say 30 km/h)
 - there is significant cycling demand and the path width is too narrow for shared use.
- Separated paths on which cyclists and pedestrians are required to use designated areas; separated paths:
 - are not common because they are justified only where there are large numbers of both pedestrians and cyclists desiring to use the path
 - should not be used in busy shopping centres where large numbers of pedestrians are expected to cross the path
 - may be one-way or two-way.

Table 7.1: Key cross-references related to paths for cycling

Section of <i>Cycling Aspects of Austroads Guides</i>					
Guide	Section	Reference source	Guide	Section	Reference source
Section 7.1: General					
	Section 2	Austroads (2009f)		Section 3.4	Austroads (2014b)
Section 7.2: Types of Path					
	Section 3	Austroads (2009f)			
Section 7.3: Choice of Appropriate Type of Path					
	Section 2.2	Austroads (2009f)			
Section 7.4: Location of Paths for Cycling					
	Section 5	Austroads (2009f)			
Section 7.5: Path Design Criteria for Bicycles					
	Section 7	Austroads (2009f)			
Section 7.6: Path Crossings of Roads (also Sections 5.3.10 and 9.5)					
	Section 8	Austroads (2009f)			
Section 7.7: Intersection of Paths with Paths					
	Section 9.3	Austroads (2009f)		Section 8.3	Austroads (2013c)
Section 7.8: Path Terminal Treatments					
	Section 10	Austroads (2009f)		Section 8.2.2	Austroads (2013c)
Section 7.9: Fences and Road Safety Barriers (also Section 7.5.7)					
	Section 6.5.2	Austroads (2010c)		Section 7.7	Austroads (2009f)
	Section 4.1.6	Austroads (2009g)			
Section 7.10: Road and Path Lighting					
	Section 7.9	Austroads (2009f)		Section 4.2	Austroads (2009g)

Notes:



Guide to Traffic Management (GTM)



Guide to Road Design (GRD)

7.3 Choice of Appropriate Type of Path

Types of path are shown in the flow chart in Figure 7.1 which is a basic guide to assist designers to choose an appropriate type of path. The flow chart only considers the primary factors needed to determine the type of treatment required. Prior to this chart being applied a decision will have been taken as to whether an on-road lane or an off-road path, or both, are required. Also, there may be other issues, constraints and practices that will have a bearing on the decision-making process.

The types of bicycle paths and their appropriate uses are discussed in Section 3 of GRD 6A.

Figure 7.1: Guide to the choice of path treatment for cyclists

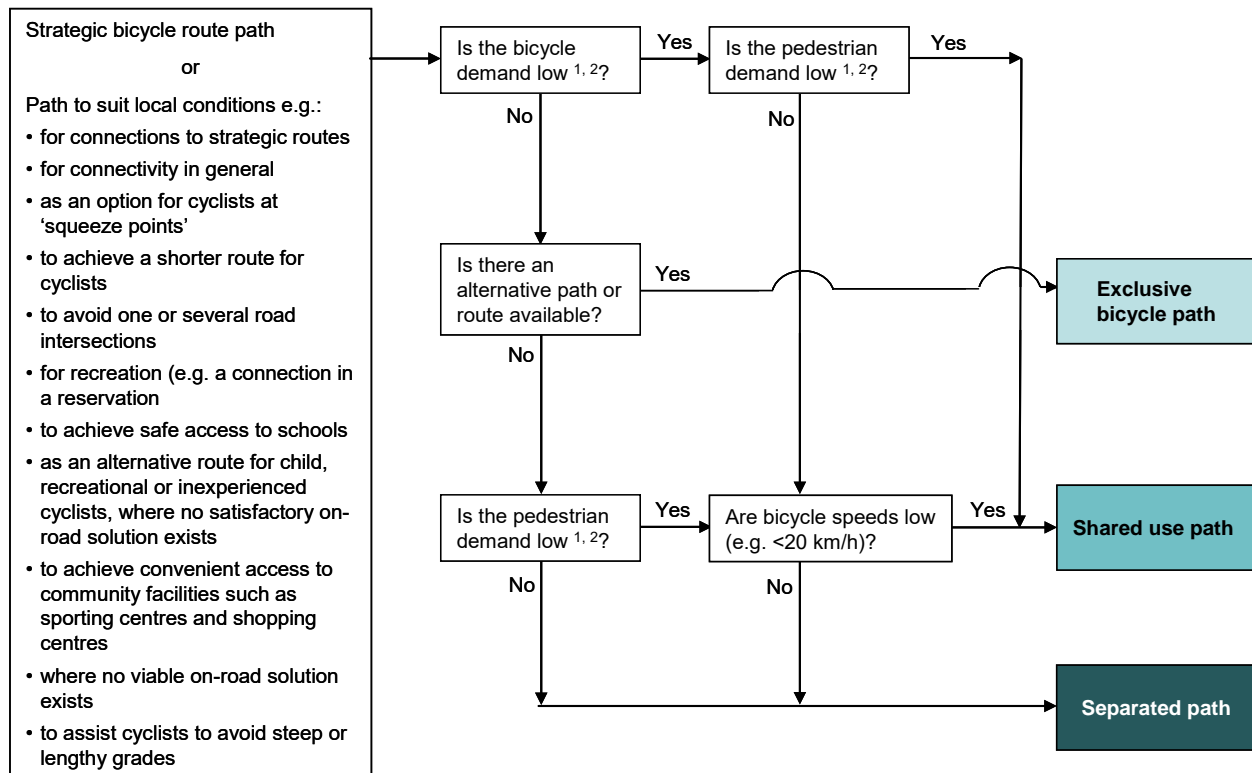

1 The level of demand can be assessed generally on the basis of the peak periods of a typical day as follows:

- Low demand: Infrequent use of path (say less than 10 users per hour)
- High demand: Regular use in both directions of travel (say more than 50 users per hour).

2 These path volumes are suggested in order to limit the incidence of conflict between users, and are significantly lower than the capacity of the principal path types.

Source: Austroads (2009f) Figure 2.1.

7.4 Location of Paths for Cycling

Paths may be located:

- in the reservations of major new or existing access-controlled arterial roads or freeways
- along river frontages
- on foreshores
- through parkland
- along railway reservations
- abutting bridges or across exclusive bridge facilities
- within the reservations of streets which have direct access to abutting property.

Commuter cyclists are likely to use paths only if the path offers a reasonably direct route or a useful connection between other links in the cycling network whereas recreational cyclists will generally accept indirect routes that provide an appropriate riding experience.

Guidance on factors that influence the detailed location of bicycle paths is provided in Section 5 of GRD 6A.

7.5 Path Design Criteria for Bicycles

7.5.1 General

Key design criteria and features for paths are provided in Section 7 of GRD 6A. Table 7.2 lists design elements and features of paths along with reference to the relevant section in GRD 6A.

Table 7.2: Cross-references for path key design criteria

Element or feature	Relevant section of GRD 6A
Bicycle operating speed	Section 7.2
Horizontal alignment	Section 7.3
Width	Section 7.5.1 General Section 7.5.2 Bicycle paths Section 7.5.3 Shared paths Section 7.5.3 Separated paths
Vertical alignment	Section 7.4 Gradient Figure 7.9 Crest curves
Crossfall and drainage	Section 7.6
Clearances, batters and fences	Section 7.7
Sight distance	Section 7.8; Figure 7.7

The following sections provide a summary of the key design criteria shown in Table 7.2.

7.5.2 Bicycle Operating Speed

Bicycle operating speeds on paths are influenced by a combination of human and other factors. It is important to recognise that under appropriate conditions many fit cyclists can maintain relatively high speeds. Speeds in excess of 35 km/h can be maintained on the flat whilst speeds of over 50 km/h can be attained on moderate gradients.

It is recommended that paths be designed for a speed of at least 30 km/h wherever possible and desirable given the purpose of the path, and in other cases for the anticipated operating speeds. However, it should be recognised that it may be necessary to adopt higher or lower design speeds in specific circumstances.

7.5.3 Horizontal Alignment

Where a path location or alignment is not constrained by topography or other physical features, a generous alignment consisting of straights and large radius curves is desirable. Such an alignment will provide good sight lines that are essential for safety as well as a pleasant riding experience for cyclists.

The minimum horizontal radii shown in Table 7.3 should be used where a flat surface is used and it is not possible or desirable to provide superelevation. Table 7.4 shows the minimum radii that should be used in combination with superelevation.

When using Table 7.4 designers and practitioners should be aware that:

- the minimum radii used on shared paths should be no less than those shown in Table 7.4, corresponding to a superelevation of 2.5%
- the values from Table 7.4 for a superelevation greater than or equal to 3% should only be used on exclusive bicycle paths
- curves should generally have positive superelevation so that they can be comfortably negotiated
- where practicable the minimum radius should not be used as tight curves can result in sight distance restrictions, a poor level of service and some cyclists choosing an informal alternative path to avoid the restriction.

Table 7.3: Minimum radii of horizontal curves without superelevation

Design speed (km/h)	Minimum radius (metres)
20	10
30	25
40	50
50	94

Note: Based on zero superelevation and friction factors of 0.31, 0.28, 0.25 and 0.21 for speeds of 20, 30, 40 and 50 km/h respectively.

Source: Austroads (2009f) Table 7.1.

Table 7.4: Minimum radius of horizontal curves that have superelevation

Speed (km/h)	Superelevation (%)				
	2	3	4	5	6
Minimum radius (m)					
20	10	9	9	9	9
30	24	23	22	21	21
40	47	45	43	42	41
50	86	82	79	76	73

Source: Austroads (2009f) Table 7.2 and California Department of Transportation (2006).

7.5.4 Width

The width of paths is an important factor given construction costs and operational considerations. It can also have a significant bearing on the level of convenience and conflict between users and potentially on path safety as well.

The path width required depends on the envelope (i.e. space) occupied by pedestrians and/or cyclists using the path together with appropriate clearances. The clearances are required between path users travelling in the same direction or opposite directions, and also between path users and the edge of the path. Some allowance for the ability of cyclists to ride in a consistent wheel path (i.e. tracking of the bicycle within the envelope) is provided.

Bicycle paths

Table 7.5 shows desirable widths and acceptable ranges of width for bicycle paths (i.e. exclusive use). The upper limit of the acceptable range in the table should not discourage designers from providing a greater width where it is needed (e.g. very high demand that may also result in overtaking in both directions).

Table 7.5: Bicycle path widths

	Path width (m)	
	Local access path	Major path
Desirable minimum width	2.5	3.0
Minimum width – typical maximum	2.5 ⁽¹⁾ –3.0 ⁽²⁾	2.5 ⁽¹⁾ –4.0 ⁽²⁾

1 A lesser width should only to be adopted where cyclist volumes and operational speeds will remain low.

2 A greater width may be required where the number of cyclists is very high.

Source: Austroads (2009f) Figure 7.3.

Shared paths

Table 7.6 shows desirable widths and acceptable ranges of width for shared use paths. As for bicycle paths, the upper limit of the acceptable range in the table should not discourage designers from providing a greater width where it is needed (e.g. very high demand that may also result in overtaking in both directions).

Table 7.6: Shared path widths

	Path width (m)		
	Local access path	Commuter path	Recreational path
Desirable minimum width	2.5	3.0	3.5
Minimum width – typical maximum	2.5 ⁽¹⁾ –3.0 ⁽²⁾	2.5 ⁽¹⁾ –4.0 ⁽²⁾	3.0 ⁽¹⁾ –4.0 ⁽²⁾

1 A lesser width should only to be adopted where cyclist volumes and operational speeds will remain low.

2 A greater width may be required where the numbers of cyclists and pedestrians are very high or there is a high probability of conflict between users (e.g. people walking dogs, roller bladers and skaters etc.).

Source: Austroads (2009f) Figure 7.4.

Separated paths

Table 7.7 and Table 7.8 show desirable widths and acceptable ranges of width for two-way and one-way separated paths respectively. However, where it is appropriate (e.g. high traffic demand) designers may provide a greater width than the typical maximum shown in the tables.

Table 7.7: Separated two-way path widths

	Path width (m)		
	Bicycle path	Footpath	Total
Desirable minimum width	2.5	2.0	4.5
Minimum width – typical maximum	2.0–3.0	≥ 1.5	≥ 4.5

Source: Austroads (2009f) Table 7.5.

Table 7.8: Separated one-way path widths

	Path width (m)		
	Bicycle path	Footpath	Total
Desirable minimum width	1.5	1.5	3.0
Minimum width – typical maximum	1.2–2.0	≥ 1.2	≥ 3.4

Source: Austroads (2009f) Table 7.6.

7.5.5 Vertical Alignment

As a general principle longitudinal gradients on paths for cycling should be as flat as possible. The potential hazard for cyclists due to high speeds on steep downgrades is as important as the difficulty of riding up the grade when determining maximum gradients on two-way paths (Section 7.4, GRD 6A).

Ease of uphill travel

Figure 7.2 shows the maximum lengths of uphill gradient acceptable to cyclists. The figure is based on a review of the ease of uphill travel (Andrew O'Brien & Associates, as cited in GRD 6A, Austroads 2009f).

In using the figure designers should understand that:

- Above 3% the acceptable length reduces rapidly and it is considered this is the desirable maximum gradient for use on paths. However, in practice there are cases where it is not feasible to achieve a 3% maximum and the designer has no choice but to adopt a steeper gradient
- In cases where 3% cannot be achieved consideration should be given to limiting gradient to a maximum of about 5% and providing short flatter sections (say 20 m long) at regular intervals to give cyclists travelling both uphill and downhill some relief from the gradient.

Safety and downhill travel on paths

Gradients steeper than 5% should not be provided unless it is unavoidable. It is most important that sharp horizontal curves or fixed objects do not exist near the bottom of hills, particularly where the approach gradient is steep (greater than 5%) and relatively straight. If a curve must be provided at the bottom of a steep grade then consideration should be given to providing additional path width, and a clear escape route or recovery area adjacent to the outside of the curve.

Many cases where gradients are in excess of 5% occur on the approaches to grade-separated facilities (e.g. underpasses) and in these situations the provision of widened paths or clear escape routes is not practicable. In these cases adequate sight distance should be provided together with appropriate delineation and warning signs.

Figure 7.2: Desirable uphill gradients for ease of cycling

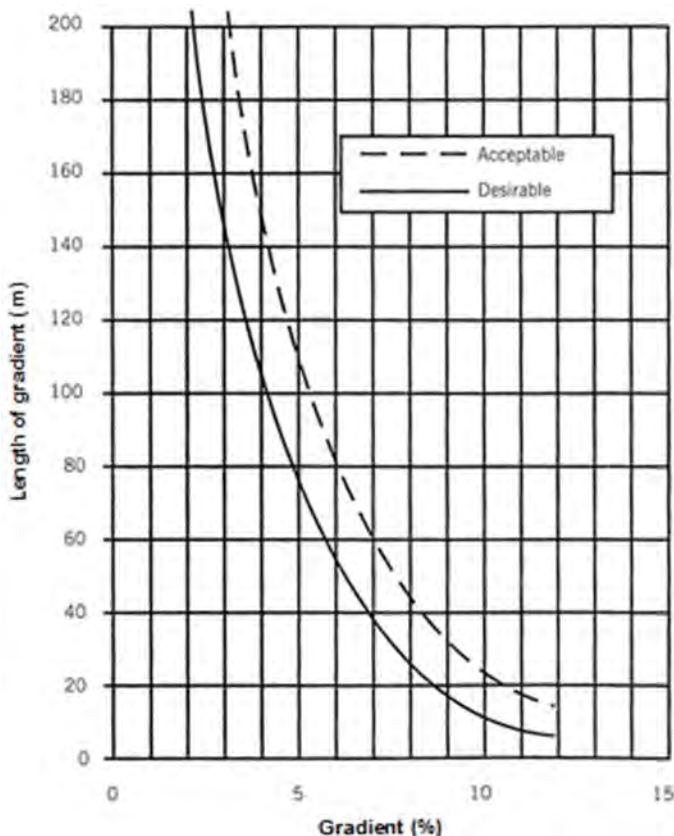

Notes:

Gradients and the associated length would normally be based on the distance between the tangent points for an isolated steep section. However, where there are consecutive grades of varying steepness (all uphill) or large radius vertical curves, these should be calculated based on the intersection points of the respective vertical curves.

In general, the 'acceptable' line in the figure would be satisfactory for paths with a high proportion of regular or physically fit cyclists, which in most instances would include commuter and sporting cyclists. Otherwise, the 'desirable' line in the figure is recommended.

Source: Austroads (2009f) Figure 7.1, based on a review by Andrew O'Brien & Associates (cited in GRD 6A, Austroads 2009f).

7.5.6 Crossfall and Drainage

Crossfall

Water ponding on paths has a significant impact on the level of service provided to cyclists as spray leads to grit on both bicycle and rider. On straight sections crowning of the pavement is preferable as it results in less accumulation of debris. On sealed surfaces a crossfall of 2-4% should be adequate to effectively dispose of surface water whereas unsealed surfaces may require 5% to prevent puddles of water from developing.

Where paths are for shared use, the needs of other path users (e.g. impaired pedestrians) should be considered. In particular, AS/NZS 1428.4.1-2009 specifies that a path crossfall should not exceed 2.5% (1 in 40) to cater for people who have a disability.

Drainage

Paths for cycling should be constructed so that water does not pond on the surface and debris does not wash onto the path during heavy rain. The path should therefore have adequate crossfall and catch drains to collect water and prevent water and litter from flowing onto the path. Typical path cross-sections are illustrated in Figure 7.3 of GRD 6A.

Major commuting and recreational paths should be designed for an equivalent flood immunity as that adopted for local roads unless suitable alternative routes can be easily accessed from the path. Major recreational paths that follow watercourses will have to satisfy the requirements of the responsible authority.

Guidance on crossfall and drainage for paths is provided in Section 7.6 of GRD 6A. For further guidance, refer to GRD 5 and GRD 5A.

7.5.7 Clearances, Batters and Fences

Clearances

It is important for safer operation that adequate clearance is provided between bicycle operating spaces for cyclists traveling in opposite directions and between the cyclist operating spaces and potential hazards beside paths (e.g. fixed objects, vertical drops, steep batters).

The clearance between cyclist operating spaces varies according to the type of use and operating speeds as follows:

- On paths designed for commuting and major recreational activity a minimum lateral clearance of 1.0 m is required between opposing bicycle operating spaces because of the high relative speed which exists when cyclists approach one another from opposite directions at speeds of 30 km/h or more (i.e. closing speed of 60 km/h).
- On recreational paths where the speeds of cyclists are not likely to exceed 20 km/h a minimum lateral clearance of 0.4 m is necessary between opposing bicycle operating spaces.

The following guidelines should be applied for clearances between the cyclist operating spaces and potential hazards beside paths:

- Where both the areas beside the path and the path alignment are both relatively flat a lateral clearance of at least 1.0 m (0.5 m absolute minimum) should be provided between the edge of any path for cycling and any obstacle, which if struck may result in cyclists losing control or being injured. However, on high-speed paths it is most desirable to have a clearance considerably greater than 1.0 m.
- Where it is considered that a hazard beside the path has attributes that could cause serious injury to cyclists (e.g. sharp surfaces such as the rear side of the posts and rails of steel W-beam road safety barrier), designers should assess the risk of cyclists losing control on the particular section of path, and consider either increasing the lateral clearance or shielding cyclists from the hazard. Depending on the situation a rub rail behind the posts or a cyclist fence near the edge of the path could be provided.
- Where a vertical drop or a steep batter exists or must be provided adjacent to the path the guidance under *Batters and fences* (below) should be applied.

Batters and fences

The installation of a fence at the side of a path used by cyclists is desirable where:

- there is a steep batter or large vertical drop located in close proximity to the path
- the path is adjacent to an arterial road and it is necessary to restrict cyclist access to the road
- a bridge or culvert exists on a path
- a hazard exists adjacent to a particular bicycle facility
- cyclists are likely to be 'blazing a separate trail' at an intersection between paths or around a path terminal.

Figure 7.3 provides specific recommendations for the provision of a fence on a path in close proximity to a steep batter or vertical drop. Reference should be made Section 7.3.6 of GRD 6A for further guidance and examples of fences. Further guidance on clearances, batters and fences is provided in Section 7.7 of GRD 6A.

Figure 7.3: Requirement for fence barriers at batters and vertical drops

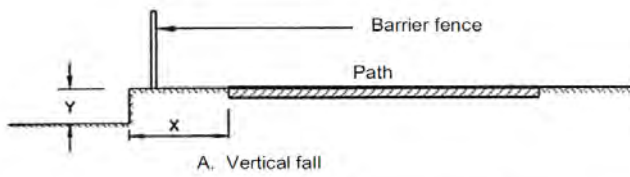

	X (metres)	Y (metres)
Fence not required*	<2	<0.25
Partial barrier fence required	<5	0.25 to 2
Full barrier fence required	<5	>2

* Batter off the surface where fall is within 1 m of path.

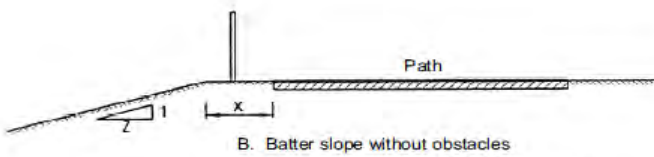

	X (metres)	Z (metres)
Fence not required	<1 1 to 5	>8 >3
Partial barrier fence required	<5	1 to 3
Full barrier fence required	<5	<1

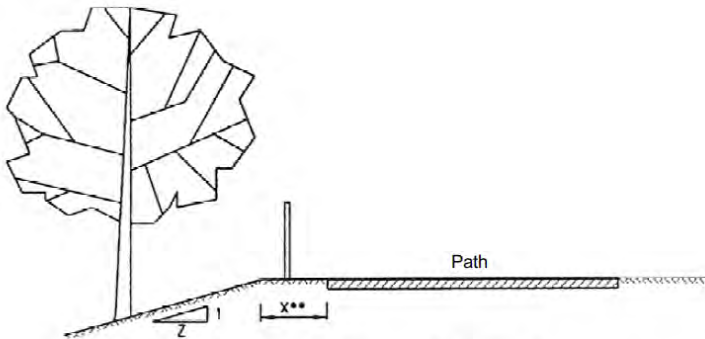

	X (metres)	Z (metres)
Fence not required	<1 1 to 5	>8 >4
Partial barrier fence required	<5	3 to 4
Full barrier fence required	<5	<3

** Barrier fence required if obstacle within 1 m of path.

Source: Austroads (2009f) Figure 7.4.

7.5.8 Sight Distance

Sight distance is covered in Section 7.8 of GRD 6A. For safer travel cyclists must be able to see across the inside of horizontal curves, under overhead obstructions in sag curves (e.g. where a path passes under a road) and over vertical crest curve a sufficient distance to enable them to stop or take evasive action if necessary in order to avoid another cyclist, a pedestrian or an obstacle in their path.

Figure 7.4 shows the stopping sight distances that should be provided to enable a cyclist to stop for various combinations of bicycle operating speeds and gradients.

It is essential that all two-way bicycle paths should be designed to provide a sight distance between opposing cyclists (i.e. as shown across a horizontal curve in Figure 7.5) at least equivalent to twice the stopping sight distance given by Figure 7.4. This is to ensure that cyclists who are overtaking can avoid a head-on collision.

Figure 7.4: Minimum stopping sight distance for cyclists

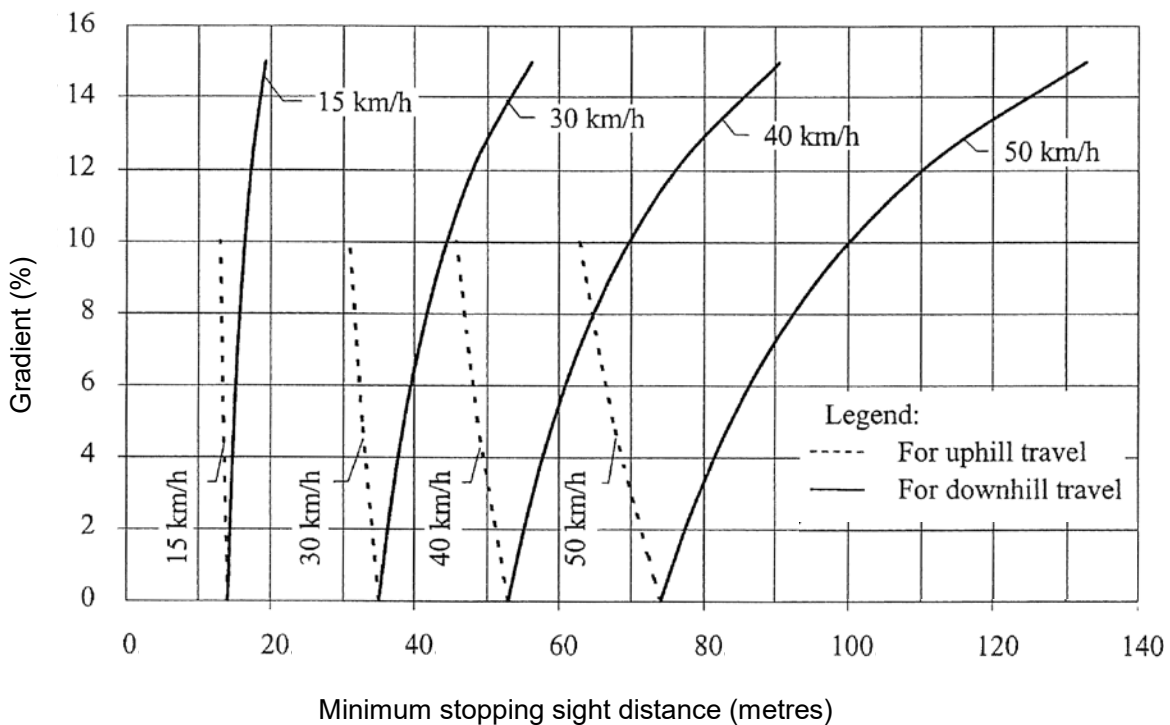

Source: Austroads (2009f) Figure 7.7 and AASHTO (1991).

Path sight distances can be drastically reduced by the growth of vegetation and hence the location and maintenance of vegetation are critical to safer path operation. Figure 7.5 illustrates the relationship between stopping sight distance, radius of the curve and the lateral clearance to significant visibility obstructions such as extensive vegetation or an earth embankment. Isolated features including trees do not necessarily constitute a significant obstruction if cyclists can see most of the curve beyond them.

Figure 7.5: Lateral clearances on horizontal curves

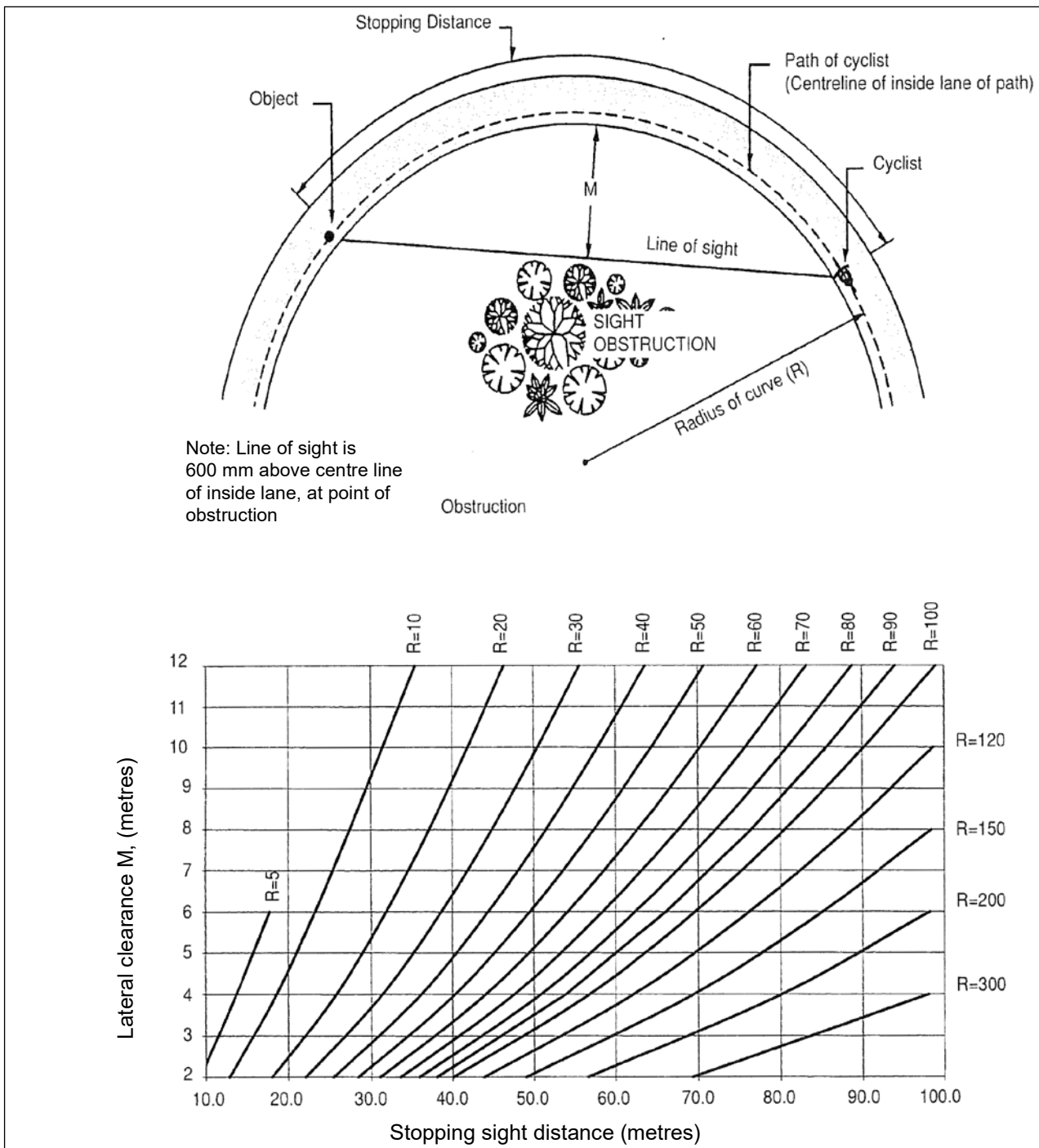

Source: Austroads (2009f) Figure 7.8 and California Department of Transportation (2006).

A vertical curve should join all changes of grade. Crest vertical curves must be of sufficient length to give the cyclist the stopping sight distance shown in Figure 7.4. Where practicable, sag curves should be the same length as equivalent crest curves to ensure comfort and an aesthetically pleasing path alignment.

Figure 7.6 shows the minimum length of vertical curves for various changes of gradient and design speeds.

Figure 7.6: Minimum length of crest vertical curves

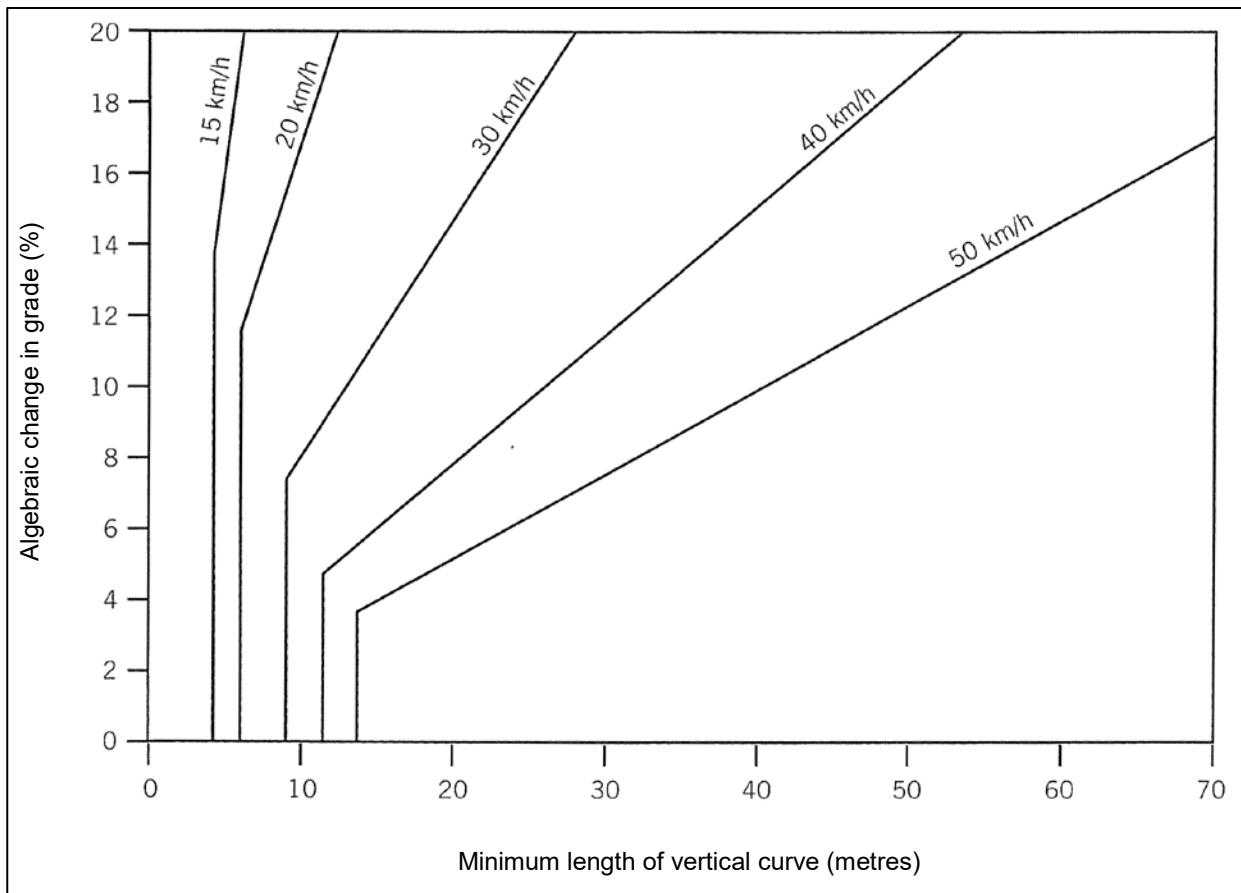

Source: Austroads (2009f) Figure 7.8 and California Department of Transportation (2006).

7.6 Path Crossings of Roads

7.6.1 General

This section discusses cyclist crossing treatments of roads for situations where cyclists either have to yield to motor vehicles or have priority over motor vehicles.

One or more of the following facilities can assist cyclists in crossing roads:

- grade separation
- a signalised crossing with bicycle detection and lights
- median refuge
- road narrowing of excessively wide roads whilst also providing for cyclist needs along the road
- on-road lanes or off-road path connections to nearby traffic signals, to be supplemented with bicycle detection and lanterns
- a crossing that gives priority for cyclists in accordance with road rules.

7.6.2 Grade Separated Bicycle Path Crossing

General

Grade separated crossings such as bicycle bridges, underpasses and overpasses may be provided to achieve a safer crossing of roads, rivers or railways. General guidance on the use of grade separations for use by pedestrians and cyclists is provided in Table 7.9.

Table 7.9: Benefits of treatments – grade separated facilities

Objectives and priority	Application	Treatment	Benefits and considerations ⁽¹⁾
To increase the safety of pedestrians and cyclists by eliminating physical conflict between them, and motorised traffic. Removes priority considerations.	Applicable at locations with: <ul style="list-style-type: none"> high posted speed high-volumes of motorised and crossing traffic multiple lanes cycle path continuity. 	Overpass, underpass	<ul style="list-style-type: none"> May require high capital cost. Grade difference of an overpass is less preferred for impaired and aged persons, and cyclists. Underpass has problems with security, lighting and vandalism. Infrequent location may not cover desire lines causing increased journey distance, fencing may be required.

¹ See Section 5 of GTM 8, GRD 4, AS 1742.9, AS 1742.10, Land Transport New Zealand (2007) and Transit New Zealand (2008).

Source: Austroads (2013c) Table 8.3.

Although often provided as part of a shared path network grade separations may be provided as a safer alternative adjacent to narrow road bridges or through the fill behind a bridge abutment. In difficult terrain a structure may be used to continue a shared path along the bank of a river.

Use of existing culverts

The desirable vertical clearance within an underpass is 2.5 m. However, this height is problematic in that a standard height of 2.4 m has been used in many existing drainage culverts constructed with crown units and is adequate. In relation to severely constrained sites, culverts with a vertical clearance of only 2.0 m have been successfully utilised to accommodate paths for cycling under roads and this is considered to be acceptable when utilising existing structures.

The relative advantages and disadvantages of using a culvert with limited clearance rather than an at-grade crossing should be evaluated. If it is decided to use a culvert of limited height, signs should be erected to warn cyclists of the reduced headroom. Other steps should also be considered including some form of external (to the culvert) roof transition (from a height of 2.5 m to the height of the culvert roof) to negate the chance of a cyclist colliding with the abrupt low roof face of a culvert. Where a square corner cannot be avoided on the culvert ceiling at the entrance to the culvert some form of cushioning should be provided on the headwall to minimise injury to cyclists who may impact their head against it.

A drainage culvert should not cater for cyclist/pedestrian use unless it satisfies the recommendations in Section 7.6.2 of GRD 6 for drainage, whilst providing adequate vertical clearance. Appropriate warning signs should be installed advising of alternative crossing points for use during higher water flows. A connecting path between the recreational path and the road is always provided to facilitate access to the path and is generally suitable for use as a bypass during high water flows. It is essential that good sight distance is provided to the culvert entrances so that cyclists have adequate warning and can see any debris, silt, etc. that may have built up around and in the culvert during and after these conditions.

If an underpass is used the alignment of the path on the approach should be designed such that users can see through the culvert. Vandal-proof lighting should also be provided in underpasses for shared paths.

Underpasses of roads should be constructed with minimal cover between the top of the underpass and the road. Whilst this may necessitate the relocation of services it has the advantage that shorter approach ramps can be used requiring less overall space. Also better opportunities for the provision of adequate sight lines may be possible in order to enhance personal security.

The gradients on approach ramps to shared path overpasses and underpasses should be in accordance with the requirements of AS 1428.1, which are summarised in Section 7.5.5 of this document. Where the facility is an exclusive bicycle path a steeper gradient is permissible in accordance with Figure 7.2.

On existing structures that incorporate right angle landings in the alignment of the approach ramps, or where adequate sight distance cannot be provided, warning signs advising cyclists and other users of the hazards should be erected.

7.6.3 Signalised Bicycle Path Crossing

It is often necessary to integrate off-road bicycle facilities with other road user requirements at signalised intersections. The design should ensure that the movements of cyclists are managed and regulated to provide adequate interaction of cyclists with pedestrians and motor vehicles.

The facility to be integrated may be a shared path, an exclusive bicycle path, or a separated path. Where a shared path passes through an intersection cyclists are expected to share the marked foot crossing with pedestrians. Where a bicycle path or a separated path is to be accommodated the cyclists and pedestrians will usually be separated on the crossing.

Signalised bicycle path crossings are further discussed in Section 5.3.10 of this document and Section 9.4 of GRD 4.

7.6.4 Unsignalised Bicycle Path Crossing

Unsignalised crossings of two-lane two-way local streets or collector roads may require cyclists to give way to road traffic, and in low volume streets (< 3000 vpd) need not provide a refuge for cyclists in the middle of the road. In such situations the treatment provides for a straight crossing of the road using kerb ramps on both sides of the road with a suitable terminal treatment. A refuge in the centre of the road is desirable on busy roads (e.g. > 3000 vpd) so that cyclists can stage their crossing. Where important cycling routes intersect with low volume local roads it may be desirable for cyclists to have priority over motor traffic.

Median refuge

Figure 7.7 shows a treatment of a bicycle path where it intersects a low-volume street. This example includes separated paths in the verges of the street. Whilst separated paths are shown the treatment can be applied where footpaths or shared paths are provided within the street. Space is often not available to provide separated paths for pedestrians and cyclists within the verge of a road. However, the arrangement illustrates that it is particularly important to clearly define the priority that applies in order to reduce the likelihood of conflict between cyclists and pedestrians at the intersection between paths.

Figure 7.7: Bicycle path crossing of a two-way two-lane road and separated paths

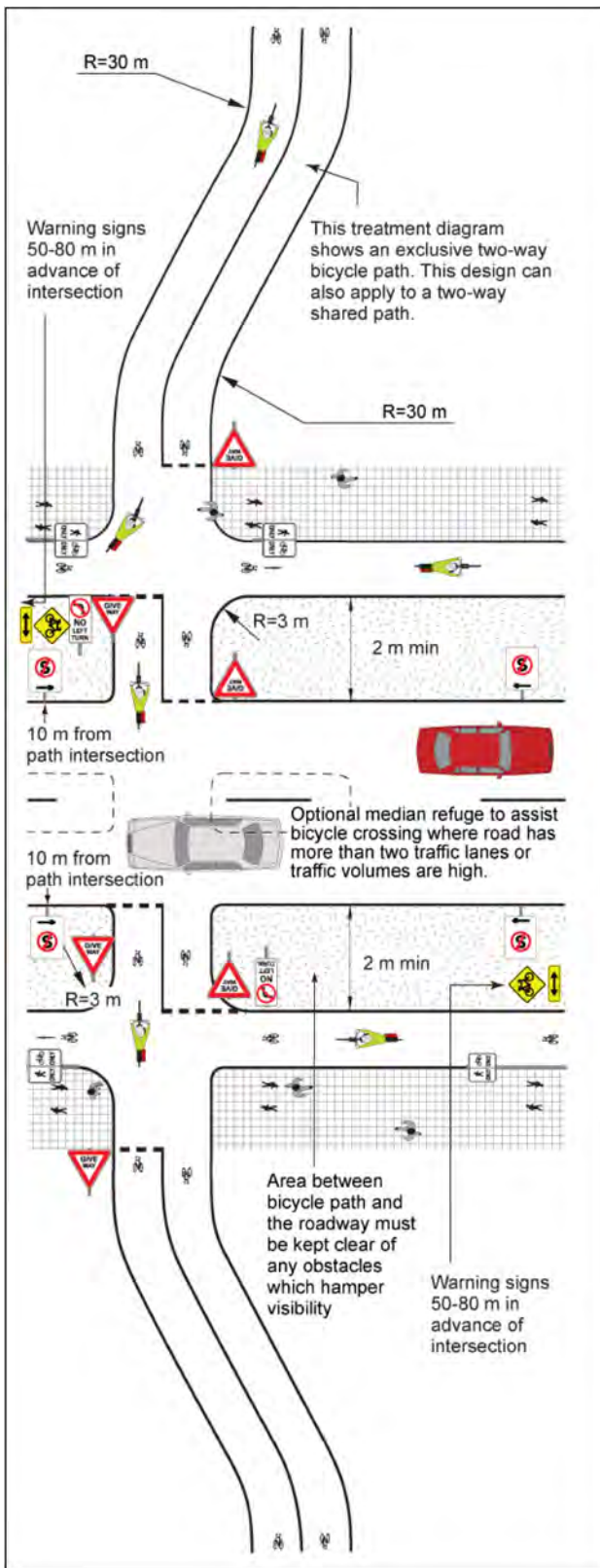

Source: Austroads (2009d) Figure 9.1, based on Roads and Traffic Authority NSW (2005).

Refuges for path crossings away from intersections

Where an off-road path crosses a busy local street or an arterial road away from an intersection it may be necessary to provide facilities to aid the cyclists to make a safer crossing. These facilities may be in the form of controlled crossings as discussed previously, or physical refuges. Physical refuges in the centre of the road are recommended to enable a staged crossing where volumes are greater than 3000 vpd. A typical refuge is shown in Figure 7.8 for a path crossing a two-way, four-lane road. Separate areas may be provided within the refuge for cyclists and pedestrians if sufficient space can be made available. Whilst the figure shows a shared path the treatment can be used for bicycle-only crossings.

Figure 7.8: Example of a cyclist and pedestrian refuge at a mid-block location

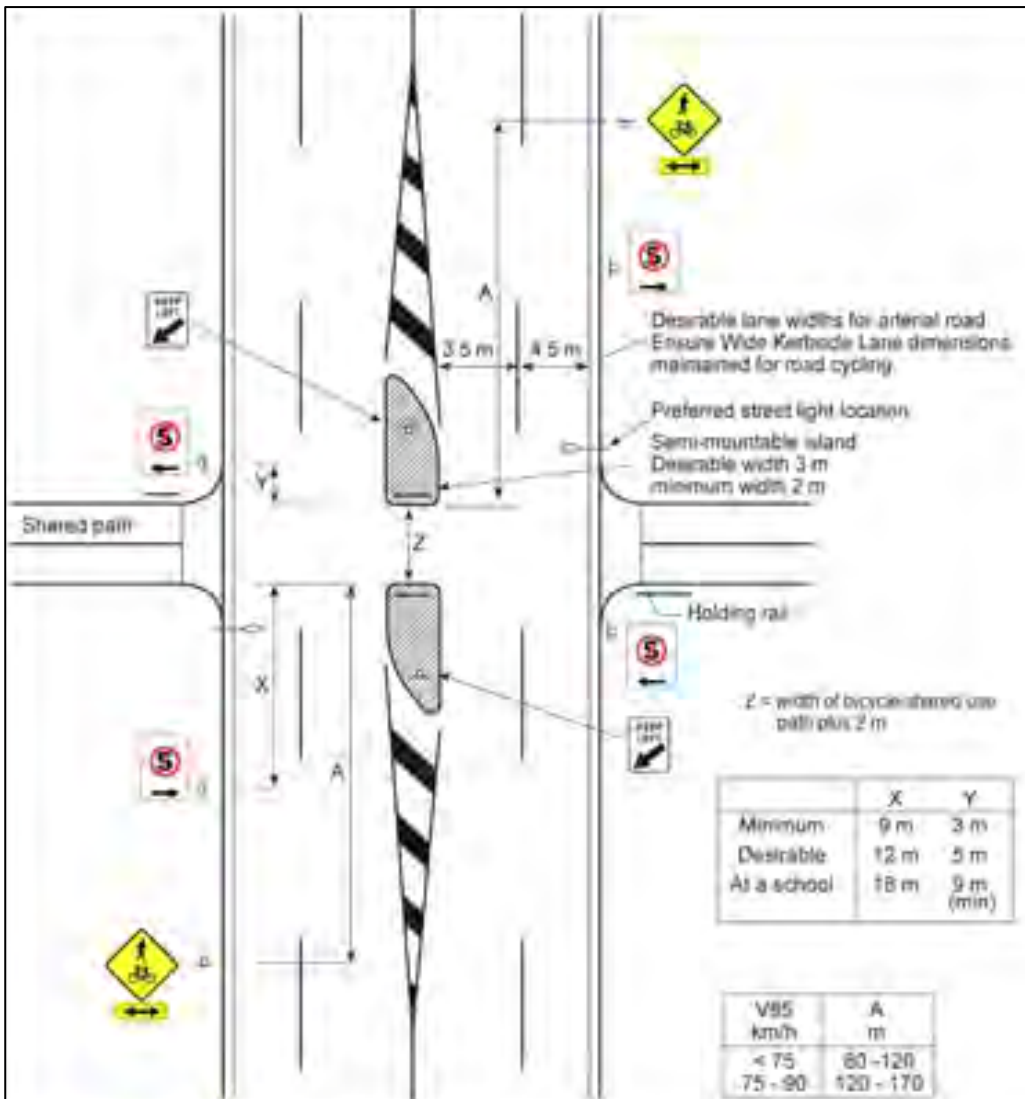

Notes:

Where required, tactile ground surface indicators should be provided on paths and ramps in accordance with AS/NZS 1428.4.1-2009 and jurisdictional guidelines.

This figure is identical to Figure 9.2 of GRD 4 except that an error has been corrected in the definition of dimension 'Z'.

Source: Based on AS 1742.10-2009.

In order to accommodate a bicycle which is typically 1.75 m long, it is desirable that a refuge be at least 2.0 m wide. However, 1.8 m may suffice in tight situations. Where there are concentrated cyclist demands at certain periods of the day (e.g. secondary schools) a wider and longer storage area may be required within the refuge to provide additional space and separate areas for cyclists and pedestrians.

Refuges can be furnished with a holding rail to allow a stationary cyclist to remain mounted within the refuge area. Rails should be located clear of the gap although where the gap is wide (i.e. greater than 2.0 m) the rails can be located within the gap, on the left-hand side. Refuges should also be provided with adequate street lighting to enhance visibility of the island and cyclists using it at night.

Cyclist priority treatment at bicycle path crossings of low-volume streets

The occurrence of low-volume local streets frequently intersecting with paths that have a significant network role can result in a poor level of service for commuter cyclists, or an inferior riding experience for recreational cyclists.

Many local authorities invest considerable resources into local area traffic management schemes and into bicycle and pedestrian path networks. An opportunity often exists to improve the continuity of paths for cyclists and pedestrians while simultaneously providing a 'device' to control speeds in local streets. The preferred treatment is a path crossing that is raised with appropriate give-way sign or stop sign controls erected to regulate road traffic. A suggested treatment for a bicycle path is shown in Figure 7.9. The treatment could be adapted to suit a shared path by providing a separated path at the crossing incorporating a marked pedestrian crossing and separately controlled space for cyclists (refer to Figure 7.11 for a similar example).

Figure 7.9: Cyclist priority treatment for use at low-volume street crossing

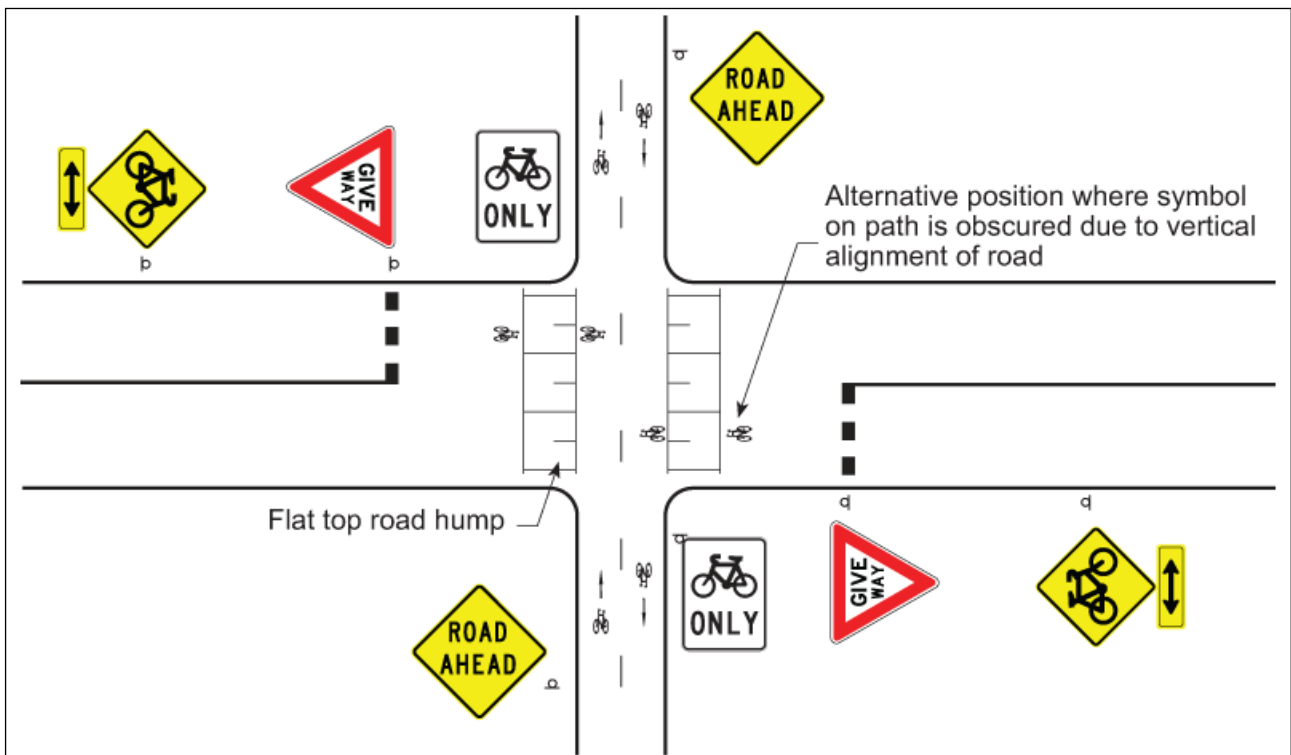

Note: Pavement marking on flat top hump to be in accordance with AS 1742 .9, Figure 3.7.

Source: Austroads (2009d) Figure 9.4.

There are legislative constraints to the use of the treatment in several jurisdictions and therefore some care needs to be taken before implementation to ensure any proposed treatment would conform to relevant requirements.

This treatment is generally appropriate where:

- it conforms to the details in Figure 7.9
- the speed environment is below the general urban speed limit, or where a local area traffic management scheme is proposed that would achieve suitable crossing conditions
- it is located in urban areas
- good visibility at the crossing point exists for both road and path users
- it is located away from intersections of roads
- the priority that would be assigned to the road is consistent with that elsewhere along the road, in the vicinity of the crossing
- not more than two lanes of traffic exist (both directions)
- the proportion of commercial traffic is low
- a warrant for a higher form of road crossing is not satisfied, such as a pedestrian actuated signal crossing, which should then be used as an alternative (AS 1742.10-1990 or relevant state regulations).
- a higher form of road crossing is not merited, such as a pedestrian actuated signal crossing, which should then be used as an alternative (AS 1742.10-2009 or relevant jurisdictional regulations).

Path crossings of side roads

Paths which run parallel to busy roads often have to cross side roads which may be minor or important traffic routes and the intersection may be signalised or unsignalised. These crossings are covered in Section 9.6 of GRD 4.

Where a bicycle path or shared path is provided in the verge of a road, cyclists using the path will often have to cross intersecting side streets. These side street crossings should be designed:

- to ensure that motorists are aware of the existence of the crossing and the priority that applies
- so that the location and design of the crossing, and the priority adopted, does not put motorists at risk when turning from the major road
- to encourage safer and correct use by cyclists.

Where the path is located on one side of a road, kerb ramps should be provided opposite every side street to enable access for local users.

7.6.5 Path Approach Design Criteria

The key requirements for the intersection between a path in a road reservation and a side road (Section 9.6.2, GRD 4) are:

- approach sight distance should be provided for drivers approaching the intersection from the side road
- drivers turning from the major road into the side street should have clear sight lines to cyclists using the path in both directions
- the speeds of cyclists using the path should be controlled on the path approaches to the intersection.

Sharp downgrades on path approaches to road crossings should be avoided where possible. Where the path alignment is straight on the approach to a road then the path should be as flat as possible. It is desirable that the longitudinal downgrade should be limited to 3% and should not exceed 5%.

Paths for cycling should be aligned to intersect roads at approximately 90°. Where the approach sight distance for cyclists is restricted, appropriate warning signs should be provided or measures taken to reduce the approach speed of cyclists.

7.6.6 Types of Crossings of Side Roads

There are three types of treatment available for the design of path crossings of side streets, a design where the path approach is bent-out (i.e. is deviated away from the major road), a design where the approach is straight, and a treatment where a one-way bicycle path is deviated to become an on-road bicycle lane. These crossings are also covered in Section 9.6.3 of GRD 4. The first two types of treatment may be applied to bicycle paths or separated paths.

For cases involving two-way paths the priority can be allocated to the path or to drivers on the side road. Give-way signs and holding lines should be used to clearly define priority and regulate the movement of cyclists and motorists.

Bent-out treatment

Where there is sufficient space in the road reservation exclusive bicycle paths or separated paths can be bent away from the parallel road at its intersection with the side road. The principal reason for bending-out is to allow storage space for vehicles turning into the side road. Therefore, bending-out is only necessary where it is desired to give path users priority.

Figure 7.10 shows a bent-out treatment on a bicycle path which allows storage space for vehicles entering and leaving the side road. The minimum distance between the path and the parallel road is 7 m to allow for a car length and clearance. The desirable minimum distance is 15 m which allows for a single-unit bus/truck and clearance.

It is essential that the area between the bicycle path and parallel road be kept clear of obstructions to visibility as motorists will otherwise lose sight of cyclists and cyclists may perceive the bending-out as a major detour and look for short cuts.

The treatment may be suitable where:

- few large, heavy vehicles (e.g. semitrailers) use the side road
- volumes on the side road are low
- speed on the major road and side road is ≤ 60 km/h.

It is also desirable that:

- an auxiliary left-turn lane is provided on the major road to minimise the likelihood of turning vehicles queuing onto the major road
- the bicycle path or the bicycle section of a separated path is delineated by a contrasting surface across the side road
- where the treatment is applied to a separated path the pedestrian priority across the side road should be achieved by installing a pedestrian crossing that complies with jurisdictional road rules and guidelines.

A bent-out treatment is not suitable for shared paths as there is currently no legal facility that would provide priority for an unsignalised shared crossing of a road (i.e. cyclists are not permitted to ride on pedestrian crossings under current road rules).

Bending-out should be achieved with smooth curves (e.g. 30 m) as the use of tight curves can introduce manoeuvres that require the cyclist's attention at a point where their attention should be focused on the crossing and approaching vehicles.

In the past there has been a common misconception among practitioners that the purpose of bending-out is to reduce the speeds of approaching cyclists. The use of tight curves, rails and bollards should not be used as speed reduction devices at these locations and normal traffic management devices such as warning signs and regulatory signs should be used to control approach speeds and crossing priority.

Figure 7.10: Bicycle path crossing bent-out at side road

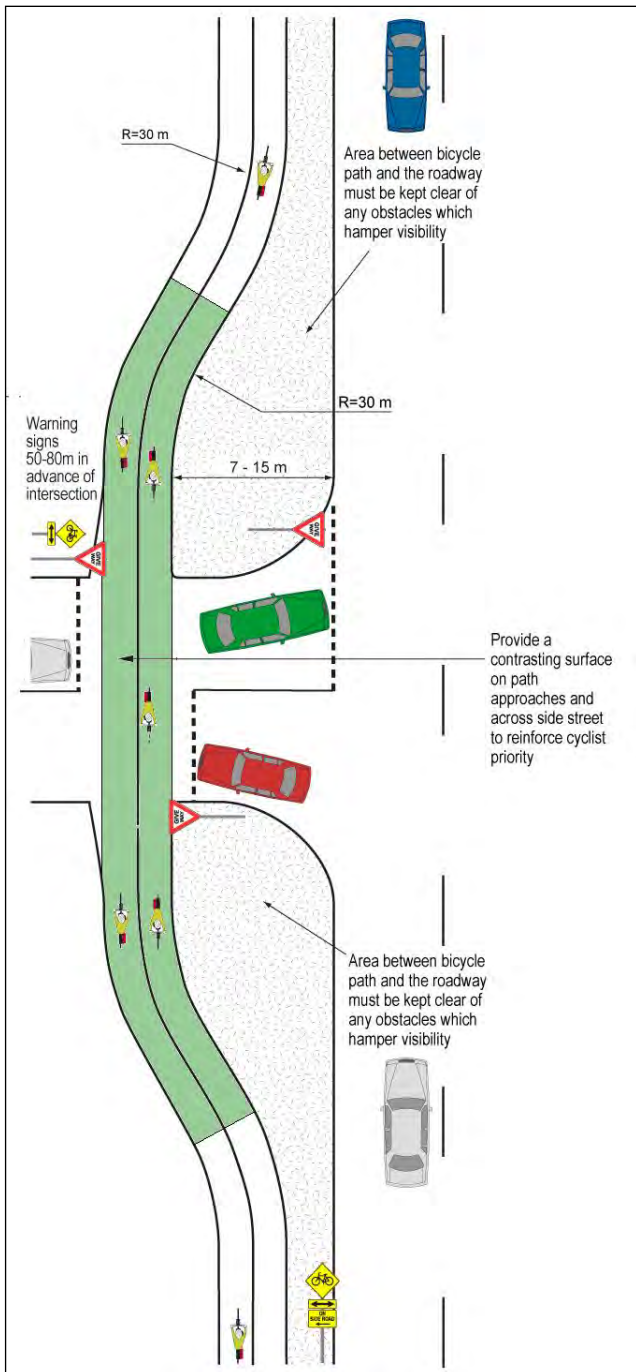

Source: Austroads (2009d) Figure 9.9, based on Roads and Traffic Authority NSW (2005).

Straight crossings (not bent-out)

Figure 7.11 shows an option for a straight crossing on a separated two-way bicycle path. The treatment provides for both cyclists and pedestrians to have formal crossings of the side street controlled by pedestrian crossing signs and give-way signs respectively. To maintain better route continuity and rider comfort this treatment may be placed on a platform as shown in the figure.

The treatment is suitable where traffic volumes in side streets are low (e.g. residential streets). Where side streets have higher volumes a bent-in treatment may be appropriate. In instances where pedestrian and cyclist volumes are relatively low, priority will often be given to motor vehicles.

The main benefit of a straight crossing relatively close to the major road is that the path has a higher visibility for road users where space for a bent-out crossing is not available. It is important therefore that the path is placed close enough to the edge of the major road to maintain visibility although at least 6 m should be provided between the treatment and the major road in order to store a car clear of the crossing. This separation also enables a left-turn auxiliary lane to be provided.

Figure 7.11: Bicycle path crossing (not bent-out at side road)

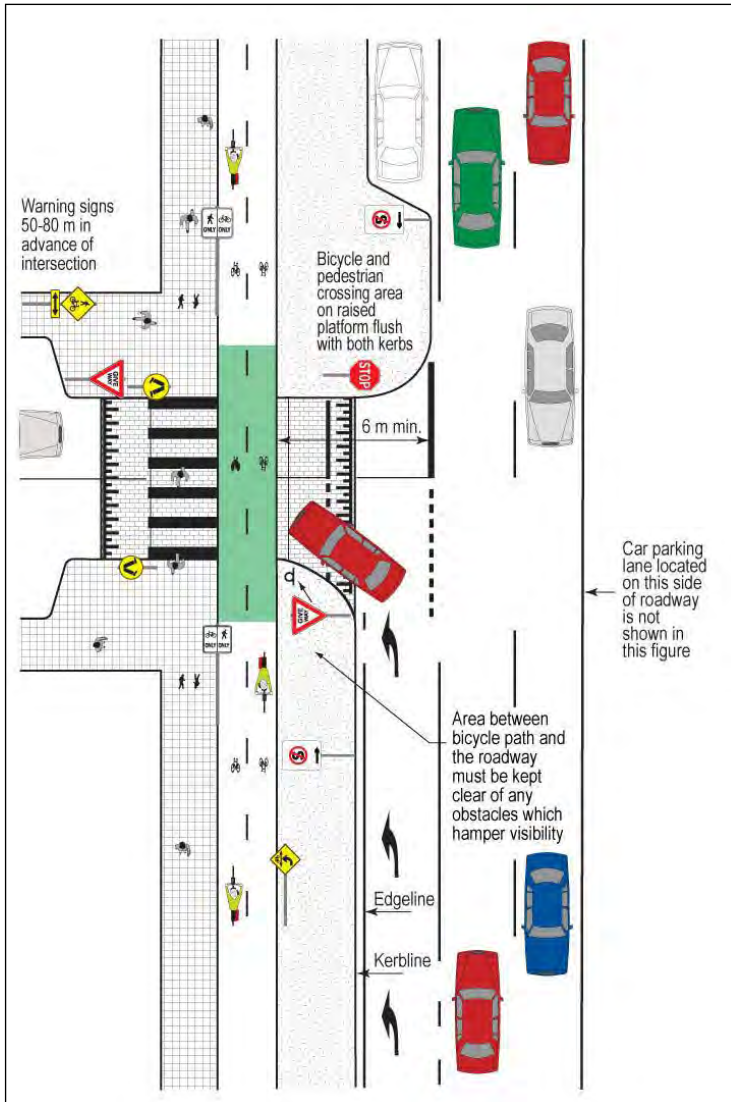

Source: Austroads (2009d) Figure 9.10, based on Roads and Traffic Authority NSW (2005).

Bent-in treatment

This treatment provides for a one-way bicycle path to transition into an on-road bicycle lane, thereby enabling cyclists to have priority across the side street. It should not be used for two-way paths because of the head-on conflict that would arise between cyclists and motor vehicles. This treatment is shown in Figure 7.12.

The bent-in treatment has the advantage of providing greater visibility of cyclists for drivers at the intersection and should enable drivers to better anticipate the movement of cyclists. It also easily provides for cyclist priority at the intersection and for the transition from path to on-road lane to be physically protected. These treatments are suitable only for experienced cyclists who have the skill and maturity to safely enter and ride in traffic. They are not suitable for paths used by children riding to schools.

If a pedestrian crossing is provided in the side street it should be located at least a vehicle storage length from the side-street holding line.

Figure 7.12: One-way bicycle path crossing (bent-in side road)

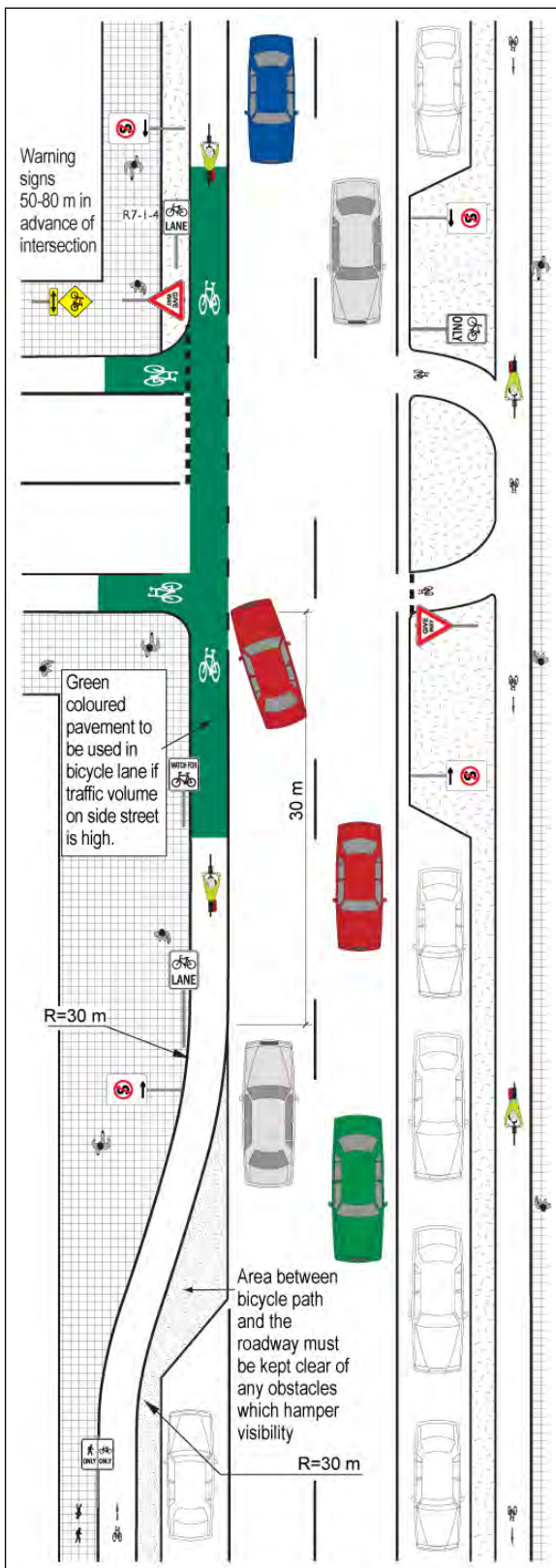

Source: Austroads, Figure 9.11 (2009d), based on Roads and Traffic Authority (2005).

7.7 Intersections of Paths with Paths

7.7.1 Considerations

Intersections between paths, bicycle paths or shared paths can be relatively basic but do require the same consideration of factors as those applied to road intersections. Some specific considerations are:

- appropriate sight distance, low gradients, adjacent areas clear of obstacles
- speed control and priority allocation where volumes are elevated
- cross-intersections which allow high-speed conflicts should not be provided
- provision of holding rails where main path volumes are high.

On shared paths and their intersections, the potential for conflict between cyclists, pedestrians and other users should be considered and, as far as possible, be minimised through traffic management and design measures.

Key conflict issues between pedestrians and cyclists on shared paths and footpaths are identified and described in the report *Pedestrian-cyclist conflict minimisation on shared paths and footpaths* (Austroads 2006b), and guidance on key conflict minimisation strategies and options are presented. Summary information on these conflicts is provided in GRD 6A.

For further guidance on intersections of paths with paths, refer to Section 9 of GRD 6A and AS1742.9.

7.7.2 Design of Intersections of Paths with Paths

Intersections between bicycle paths and shared paths are relatively simple arrangements as shown in Figure 7.13. In general, the intersections of paths should be constructed and controlled in accordance with the established principles of codes of practice for roads. For instance, at path junctions, the controls and layout should favour the predominant flow on the major through route and meet geometric requirements such as sight distance and gradients. Also, designers must ensure that the construction and controls are consistent with local regulations.

At these intersections:

- a staggered T arrangement should be adopted to prevent high crossing speeds
- the intersection angle should not be less than 70° to achieve acceptable observation angles and angles of conflict
- pavement markings should include centre lines and give-way holding lines
- pavement splays in the corners should have a minimum radius of 2.5 m.

Figure 7.13: Intersections of paths with paths

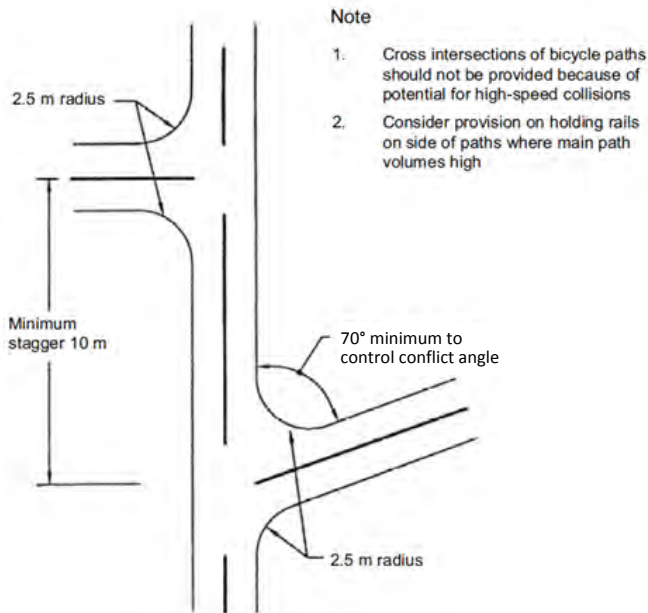

This figure is identical to Figure 9.1 of GRD 6A except that an error has been corrected in the requirements of the intersection angle.

Source: Austroads (2009f) based on Figure 9.1.

Cross-intersections should not be provided between intersecting bicycle paths or shared use paths because they allow high-speed conflicts to occur. The designer or responsible person will have to nominate which path is to have priority at intersections between paths. Priority should normally be given to the path that has the highest daily volume of cyclists and pedestrians. Where path volumes are low or similar on both paths the choice should be made on the basis of function within the network or priority should be given to the traffic stream that will be most disadvantaged through having to stop and accelerate to speed (e.g. one path may have a steep upgrade on the departure).

A similar approach can be applied to the determination of priority where a bicycle path or shared path intersects with a footpath (which cyclists are not allowed to use or infrequently use) except that a cross-intersection arrangement may be appropriate.

Considering that cycling and walking are two sustainable forms of transport the priority should depend on which mode is impacted to the greater extent by having to give way. As a general rule, where volumes are low to moderate, cyclists will be disadvantaged more than pedestrians because of the effort required to brake and accelerate up to operating speed. However, at higher volumes some pedestrians (e.g. elderly or mobility impaired) may have difficulty in crossing the shared path or bicycle paths due to the speed of cyclists in which case priority may be given to the footpath.

To ensure priority requirements are emphasised consideration should be given to the construction of additional controls at the intersections of exclusive paths or segregated paths with footpaths, where:

- paths are well used
- the footpath is used regularly by people who have a vision impairment
- sight distance constraints exist.

Figure 7.14 and Figure 7.15 show four arrangements where a bicycle path or shared path intersects with a footpath and priority is reinforced through delineation and traffic control devices. Figure 7.14 illustrates cases where cyclists have priority and respectively show how pedestrian ramps or contrasting surface material on the footpath can be used to provide an interface between the paths. Figure 7.15(a) and Figure 7.15(b) are cases where pedestrians have priority at an intersection with a shared path and a separated path respectively and show the use of give-way signs to control cyclists and contrasting surfaces to emphasise that pedestrians have priority.

Other factors that should be considered in relation to intersections of shared paths are:

- T-junctions in busy locations should be widened to allow for through cyclists to pass a turning cyclist as the extra space reduces the number and intensity of conflicts. Where hold rails are used in the side path the width should cater for turning cyclist envelopes plus additional lean allowance.
- The area around path intersections should be kept clear of hazardous obstacles, such as log barriers, to provide cyclists with a recovery zone. Any landscaping or planting should be low and 'soft'. However, landscaping is useful where cyclists may attempt to travel the shortest path between path junctions or at sharp curves, which inevitably results in maintenance problems.
- Care should also be exercised in the location of intersections on paths adjacent to watercourses so that water holes and steep embankments do not present a hazard to cyclists. The treatment at the sides of paths should provide a forgiving environment in terms of cyclist safety.

Figure 7.14: Intersection of bicycle path and footpath where cyclists have priority

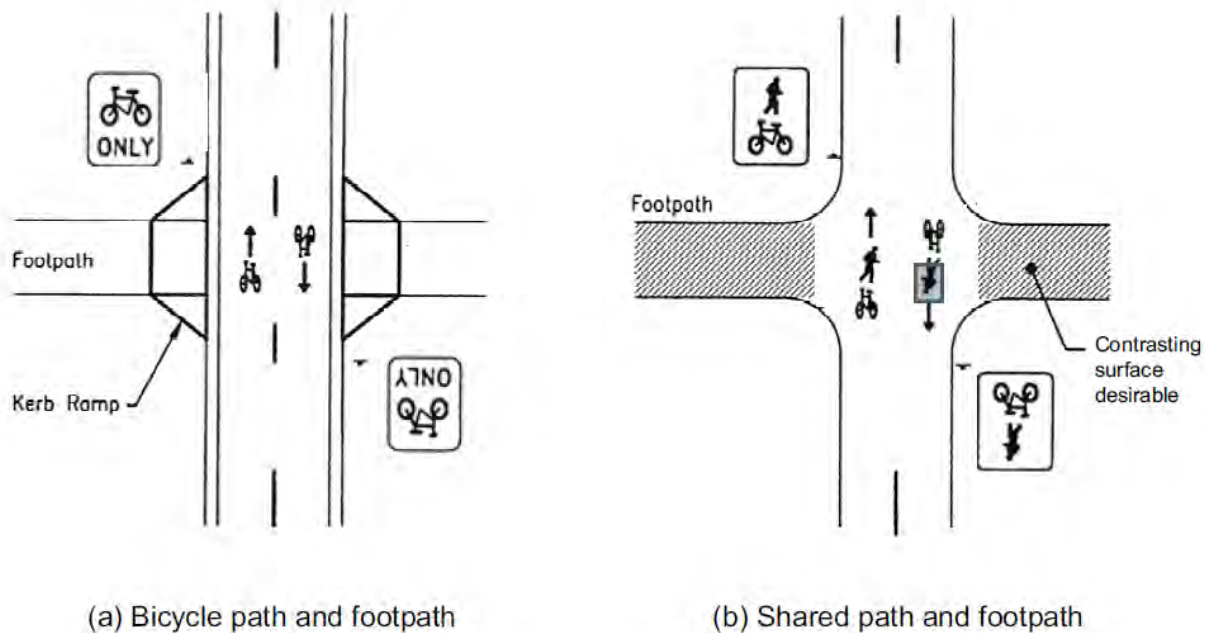

Source: Austroads (2009f) Figure 9.2.

Figure 7.15: Intersection of a separated path and footpath (cyclists give way)

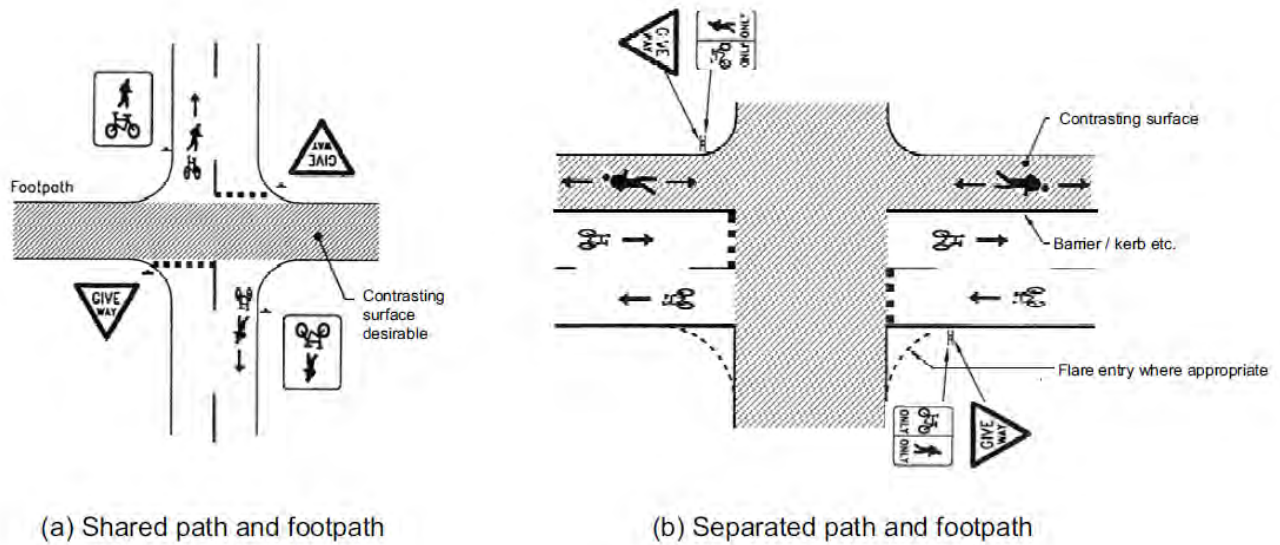

Source: Austroads (2009f) Figure 9.3.

7.8 Path Terminal Treatments

A path terminal treatment may be required where a shared path or bicycle path intersects with a road and applies to recreational and commuter paths that cross a road from a reservation, or to paths that follow a major road and cross side streets. Guidance on the use and design of path terminal treatments is provided in Section 10 of GRD 6A.

Path terminal treatments for off-road, shared paths and bicycle paths are generally provided to:

- restrict illegal access by drivers of motor vehicles to road reserves and parkland to prevent damage to paths and other assets and prevent rubbish from being dumped illegally
- advise cyclists that there is a road ahead and slow cyclists down before they cross the road.

The objective of a path terminal treatment is to prevent illegal vehicle access with a design and/or device that maintains a safer operating environment for cyclists. GRD 6A provides examples and guidelines for the design of the treatments that include separation of entry and exit, bollards or staggered fences (refer to Figure 7.16, Figure 7.17 and Figure 7.18).

Figure 7.16: Separate entry and exit terminal

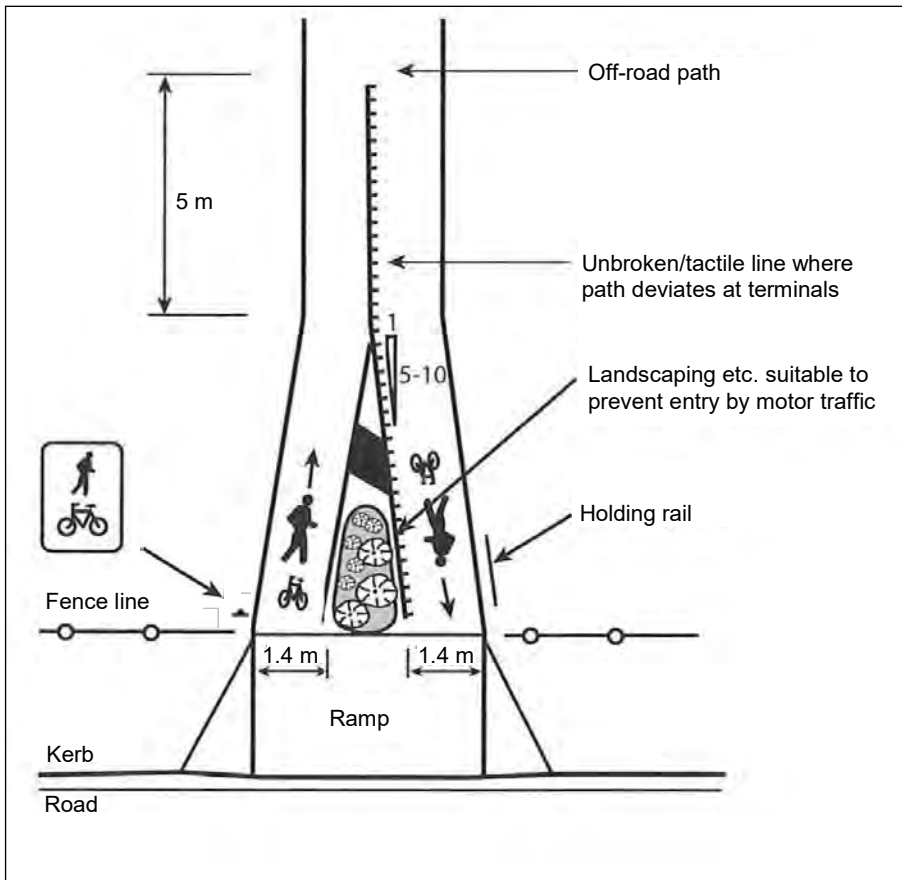

Source: Austroads (2009f) Figure 10.1, based on VicRoads (2005).

Figure 7.17: Example of a bollard treatment



Source: Austroads (2009f) Figure 10.3, and Roads and Traffic Authority NSW (2005).

Figure 7.18: Staggered fence treatment



Source: Austroads (2009f) Figure 10.6.

7.9 Fences and Road Safety Barriers

7.9.1 Fences

The need for fences in relation to batters adjacent to paths and required clearances is summarised in Section 7.5.7 of this document and discussed in Section 7.7 of GRD 6A. A fence may be required to prevent errant cyclists from running off the path into a hazardous area adjacent to the path.

7.9.2 Road Safety Barriers

Guidance on the use of road safety barriers with respect to pedestrians and cyclists using roads and paths is provided in GRD 6.

Cyclists and pedestrians may require a barrier to prevent them inadvertently running onto a traffic lane from an adjacent path. In cases where there is no need to protect path users from errant vehicles, or errant vehicles from roadside hazards, a fence of a suitable height for cyclists will be adequate.

Where there is a need to provide a safety barrier between a path and road traffic it is important that the rear of the safety barrier is not a hazard for pedestrians and cyclists. Designers should ensure that:

- Adequate clearance is provided between the rear of the safety barrier and the path (refer to GRD 6A).
- No sharp edges, burrs or other potential hazards (e.g. protruding bolts) exist.
- Where sufficient clearance cannot be provided, cyclists are protected from 'snagging' on posts by the provision of suitably designed rub rails or other appropriate means.

- Where sufficient clearance cannot be achieved, consideration is given to the need to increase the height of the barrier either to prevent errant cyclists from falling over the barrier and into a traffic lane or to discourage pedestrians from jumping over the barrier to cross the road at an unsafe location.

Where sufficient space is available a frangible pedestrian fence may be erected behind the road safety barrier at a distance that would accommodate the likely deflection of the barrier under impact by an errant vehicle. Adequate clearance is also required between pedestrian fences and bicycle paths and shared paths. In situations where space is restricted, it may be necessary to consider provision of a higher rigid barrier.

Designers should ensure that any extension to the height of a barrier would not be detrimental to its performance under vehicle impact or result in components being hazardous to motorists or path users in the event of a crash with the barrier (e.g. horizontal rails spearing vehicles).

Where pedestrian facilities are incorporated behind a road safety barrier system, the desirable minimum height of the barrier is 1200 mm above the surface of the footway. Where provision for cyclists is required, the desirable minimum height above the surface of the path should be 1400 mm.

Access through barriers

Preferred practice is to avoid providing breaks in a safety barrier. However, it may be necessary to consider breaks at locations such as intersections, points of access to property, sites where pedestrians cross the road, and access points in medians. Where breaks are necessary safe end treatments must be provided.

Bridges and overpasses

AS 5100 Set-2007 provides information on barriers for bicycle and pedestrian bridges and for some design elements for bicycle/pedestrian paths as they relate to bridges.

Temporary barriers and roadworks

During roadwork activities, consideration needs to be given to providing bike and/or pedestrian access through the works. Other times where provision of temporary barriers may be required include during special events where there is a need to control vehicle and pedestrian movements.

7.10 Road and Path Lighting

Road and path lighting is covered in GRD 6B. This Guide provides guidance for road designers and other practitioners on the types of features and facilities that may need to be accommodated within a roadside. With respect to bicycle facilities it also includes information on fences, stock grids and parking.

Bicycle path lighting is also covered in Section 7.9 of GRD 6A. Where bicycle paths or shared paths carry a substantial number of cyclists during periods of darkness (i.e. dawn, dusk and at night) consideration should be given to the provision of path lighting. The decision to provide lighting is a matter for the relevant authority. If it is decided to light a bicycle path or shared path the lighting should be designed in accordance with AS/NZS 1158.3.1-2005, (e.g. lighting level P2 or higher depending on the jurisdiction, location and the circumstances).





8. Cycling Provision at Structures

8.1 General



The design of structures is very important to cyclists. Existing road bridges are often narrower than the road on the approaches thus creating a squeeze point for cyclists. Because of the high relative cost of new bridges there is an understandable tendency for designers to be as economical as possible in the widths provided for the various users. It is important, however, that road managers look for ways to better cater for cyclists at all existing structures and that designers and planners ensure that cyclists are adequately provided for in the design of all new structures.

Guidance on the provision of facilities for cyclists at structures is covered in Section 11 of GRD 6A (Austroads 2009f).

Table 8.1: Key cross-references related to cyclist provision at structures

Section of <i>Cycling Aspects of Austroads Guides</i>					
Guide	Section	Reference source	Guide	Section	Reference source
Section 8.1: General					
	Section 11	Austroads (2009f)			
Section 8.2: Bridges and Underpasses					
	Section 11	Austroads (2009f)		General	Austroads Guides
Section 8.3: Road Tunnels					
	Section 11	Austroads (2009f)		General	Austroads Guides

Notes:

	Guide to Road Design (GRD)		Guide to Bridge Technology (GBT)		Guide to Road Tunnels (GRT)
---	----------------------------	---	----------------------------------	---	-----------------------------

The structures may cross rivers, railway lines or busy roads. They may be overpasses or underpasses that cater for motor traffic, small bridges or underpasses specifically for cyclists and pedestrians, large drainage culverts which also accommodate cyclists or a bicycle structure attached to a road bridge.

8.2 Bridges and Underpasses

The primary requirements of cyclists using bridges and underpasses are that designers should provide:

- adequate path width and/or bicycle lane width and horizontal clearances to objects (e.g. walls, safety barriers, kerbs, fences, poles, street furniture etc.)
- adequate vertical clearance, particularly in underpasses
- good sight lines into and through structures
- a smooth surface that is not slippery under any conditions including the surface of expansion joints
- adequate turning radii at changes of direction on pedestrian/cyclist overpasses and underpasses
- adequate drainage infrastructure, particularly at each end of underpasses.

For additional guidance on bridges and accommodating the needs of cyclists, practitioners are referred to the *Guide to Bridge Technology*.

8.3 Road Tunnels

Provision for cyclists in long road tunnels is problematic because of the very high cost of providing space within major tunnels, particularly treatments that provide a safer and healthy cycling environment. Nevertheless, the needs of cyclists should be considered as part of the planning and design of tunnels and if a satisfactory facility cannot be provided within the tunnel the availability or provision of a suitable alternative route should be investigated.

For further information on cyclist considerations at road tunnels, practitioners are referred to the *Guide to Road Tunnels*.







9. Traffic Control and Communication Devices

9.1 General

Traffic control and communication devices include all signs, traffic signals, pavement markings, traffic islands, or other devices installed with the approval of a road agency having the necessary jurisdiction, to regulate and guide cyclist, motor vehicle and other road user traffic. For additional guidance on the use of these devices, refer to GTM 10.

Cross-references to the guidance discussed in this section are shown in Table 9.1. Note that traffic control devices used at rail crossings are discussed separately in Section 6.

Table 9.1: Key cross-references related to traffic control and communication devices

Section of <i>Cycling Aspects of Austroads Guides</i>					
Guide	Section	Reference source	Guide	Section	Reference source
Section 9.2: Signs (also Section 2.4.5)					
	Sections 3 and 4	Austroads (2009b)			
Section 9.3: Pavement Markings					
	Section 6	Austroads (2009b)			
Section 9.4: Pavement Surface Colour					
	Section 6.6	Austroads (2009b)			
Section 9.5: Cyclists at Traffic Signals (also Sections 5.3 and 7.6.3)					
	Sections 8.1.4, 8.3.7, 8.5.5 and 8.8.2	Austroads (2009b)		Sections 7.6.11 and 7.9 Appendix H.6	Austroads (2014c)
	Section 5	Austroads (2013c)			

Note:

 Guide to Traffic Management (GTM)

9.2 Signs

Signing of bicycle facilities provides the information to assist all road users to move safely and conveniently on the road and bicycle network. The three main categories of signs and their functions are:

- regulatory signs – regulate and advise the type of facility within the context of the overall road system, e.g. whether a facility is shared with pedestrians or for the exclusive use of cyclists
- warning signs – warn users of identifiable potential hazards within the riding environment
- guide signs – guide users around the network.

9.2.1 Signing of Bicycle Routes

Bicycle routes should be signposted to indicate destinations and, if required, the distance to them. Uniformity of design and application of signs is desirable to avoid confusion and potential hazardous situations, applicable particularly for bicyclists travelling away from their local area. Guidance on signs, markings and signals for bicycles is provided in GTM 10. Practitioners should also refer to AS 1742.2-2009 which provides information on general signage and AS 1742.9-2000 as it provides details of facilities including signage specifically for bicycles.

The Australian Bicycle Council website (Appendix B, www.bicyclecouncil.com.au) provides examples of a number of bicycle signing schemes.

9.3 Pavement Markings

In addition to signs, the safety and effectiveness of bicycle facilities is dependent on the provision of appropriate and high-quality delineation including pavement markings.

Pavement markings are necessary for all on-road facilities and also for major bicycle paths, shared paths and separated paths.

9.3.1 Roads

Bicycle lanes are generally separated from general traffic by a 100 mm wide continuous white line. In areas where bicycles and motor vehicles cross or intersect, continuity lines are used to define the bicycle lane. Figure 9.1 provides an illustration of a bicycle lane treatment for a road that shows the marking treatment through an unsignalised intersection, on the approach to a signalised intersection including a 'head-start' treatment, and adjacent to angle parking.

9.3.2 Paths

Separation lines on shared paths and bicycle paths should be marked in accordance with AS 1742.9-2000.

Figure 9.1: Example of bicycle lane markings

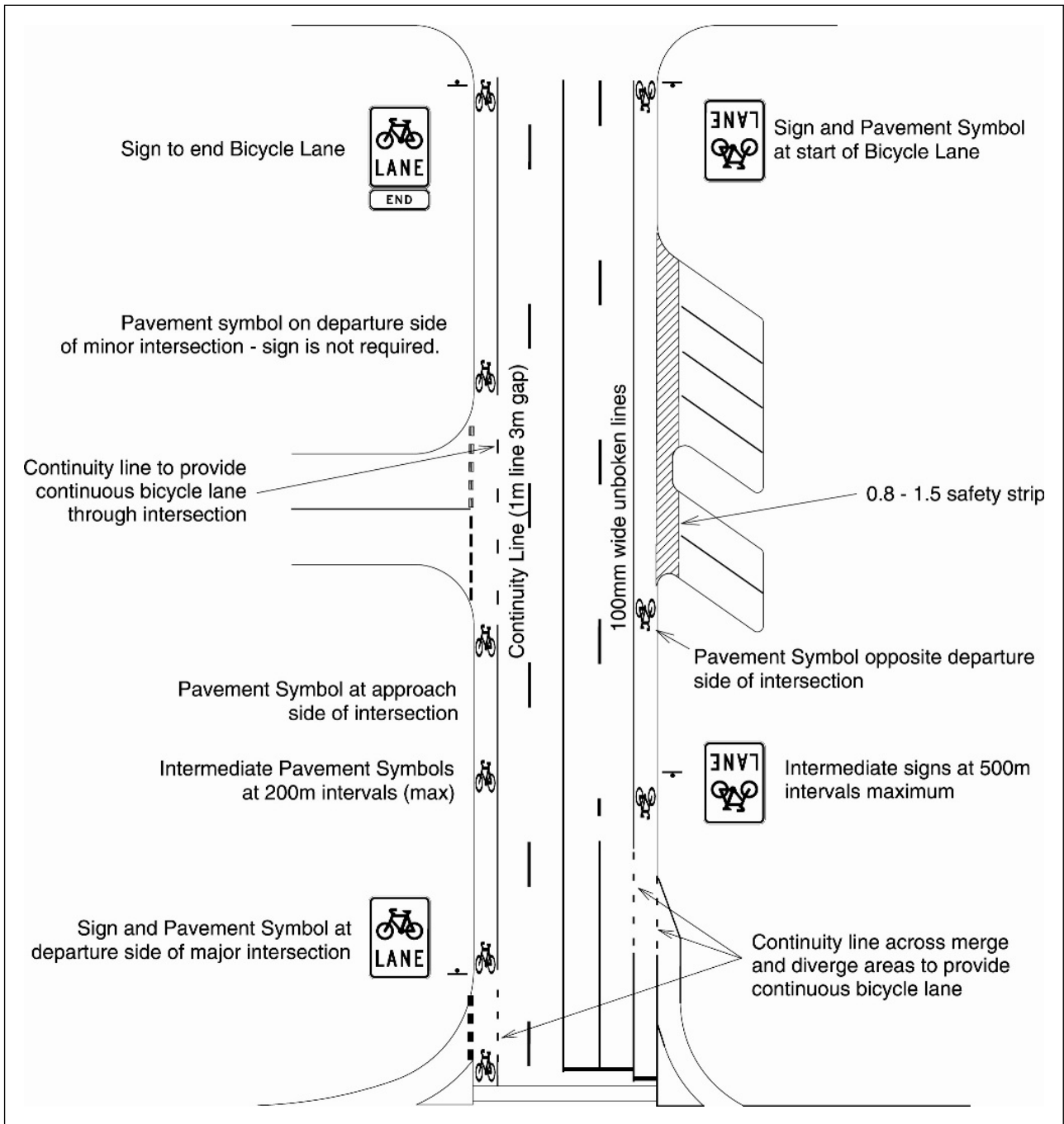

Source: Austroads (2009c) Figure 6.5 and VicRoads (2011).

9.4 Pavement Surface Colour

Green coloured pavement surfaces may be used to enhance the delineation of areas of pavement that are used for bicycle lanes. The recommended Australian Standard colour for bicycle facility surfacing is Emerald Green G13 (refer to Section 6.6, GTM 10).

An example of a bicycle lane with a green coloured surface treatment is shown in Figure 4.1 (of this document).

The surfacing is relatively expensive, and guidelines for its use vary among jurisdictions. Some road authorities are choosing to provide coloured surfacing throughout the entire area of some bicycle lanes in order to provide enhanced recognition by motorists and to improve compliance.

The use of green surfacing for bicycle lanes by some authorities may be limited to areas where cyclists experience considerable stress, such as:

- areas where the paths of motor vehicles and bicycles cross or weave, typically on the approaches and departures of intersections at the tapers to left-turn lanes and added lanes (diverge and merge areas)
- within particularly complex intersections, or very wide intersections, where enhanced delineation of the bicycle lane is essential.

Practitioners are also referred to Austroads (2011c), which found that coloured cycling facilities were of substantial benefit at signalised intersections.

9.5 Cyclists at Traffic Signals

9.5.1 Traffic Signal Displays for Cyclists

Traffic signal displays for cyclists are discussed in Section 8.1.4 of GTM 10 and Appendix H.6 of GTM 9.

Where regulations permit, bicycle aspects can be used in a similar way to pedestrian aspects to control cyclists crossing the road, or in a similar way to vehicle aspects to control on-road cyclists at an intersection. The symbol for bicycle aspects is shown in Figure 9.2.

Figure 9.2: Bicycle signal aspect

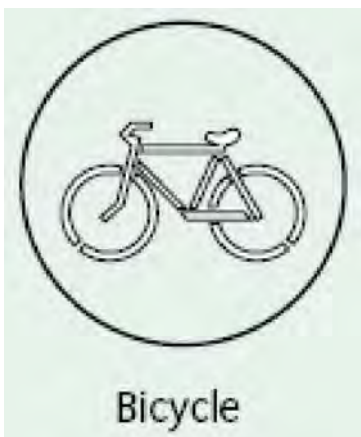

Source: Austroads (2009c) Figure 8.1.

Two aspects, red and green, are used for road crossings (except in New Zealand). Three aspects – red, yellow and green – are used at road intersections with exclusive bicycle lanes, or at intersections of a road and exclusive bicycle path. Under the *Australian Road Rules* traffic signals relating to cycling movements are called bicycle crossing lights.

Two-aspect bicycle crossing lights used at mid-block signalised crossings or intersection signalised crossings are connected to the same signal group in the controller that drives the two-aspect pedestrian signal faces. In this case, the pedestrian 'walk' and 'clearance' times apply to the bicycles as well.

Three-aspect bicycle crossing lights can also be used at signalised intersections. In this case:

- For bicycle movements parallel with a main road and crossing narrow minor roads, the bicycle crossing lights are connected to the adjacent vehicle signal group, and introduced with the green display for vehicles and terminated with the vehicle movement.
- For bicycle movements across a main road, and for those parallel with a main road and crossing wide minor roads, the bicycle crossing lights are driven by a separate signal group with green, yellow and red times that reflect a bicycle speed of 20 km/h.

The following measures can be adopted in order to allow for slower speeds of cyclists compared with vehicle speeds:

- Adjusting the yellow time for the bicycle movement to warn cyclists to stop before other traffic in the same phase, i.e. increase the intergreen time only for the cyclists (effectively providing an early cut-off). Since this reduces the bicycle green time, it should be ensured that the combined green plus intergreen time is sufficient for a cyclist accelerating from rest at the stop line to clear the controlled area.
- Allowing the cyclists to move off before the vehicle traffic (late start). This is appropriate where the bicycle lane does not continue through the intersection and bicycles have to merge with other traffic.

It is recommended that, at intersections, a stop line for bicycles is placed 2 m downstream of the normal stop line so that left-turning motor vehicle drivers, in particular bus and truck drivers, will be aware of bicycles waiting for a green signal. If vehicles cannot turn left, there is no need for this treatment.

9.5.2 Bicycle Detection

Bicycle detection at signals is covered in Section 7.6.11 of GTM 9.

When separate bicycle lanes are provided and bicycle detection is required, loop detectors with very sensitive loop arrangements spanning the whole width of the bicycle lane are necessary.

Where bicycle traffic shares lanes with other vehicles, it is not always possible to detect bicycles due to their small electromagnetic footprint. It might be appropriate in such cases to install other devices such as push buttons to assist bicycle riders to lodge a demand, or pavement markings to indicate the most bicycle-sensitive area of the detection zone or, where bicycle volumes are low, do nothing.

9.5.3 Treatments for Cyclists at Traffic Signals

A number of situations may necessitate traffic signal treatments which cater to specific road user groups such as cyclists.

Table 9.2: Signal timing and phasing treatments for cyclists

Traffic signal treatment	Comments
Late start for vehicles (early start/leading interval for cyclists)	<p>Bicycle phase is started prior to parallel vehicle phases.</p> <p>An early start positions cyclists where they are more likely to be noticed by motorists when a parallel vehicle phase begins.</p> <p>May assist where cyclists are required to merge downstream of intersection (e.g. bicycle lane does not continue through intersection).</p> <p>Most effective where cyclists are able to pass queued vehicles (e.g. locations with bike lane or wide kerb-side lane).</p> <p>May be implemented in conjunction with an early start for pedestrians depending on the specific layout, signal displays and operation of signalised intersection.</p> <p>May be considered with an early start for buses in some situations, such as where cyclists share bus priority lanes (i.e. to reduce conflict between cyclists queued in front of buses during an early start for buses).</p>
Extended clearance interval	<p>The intergreen time (e.g. yellow time) for a bicycle movement may be longer than for other traffic (i.e. early cut-off of cyclist movement).</p> <p>A cyclist may travel slower than other vehicles and may not have sufficient time to safely clear an intersection (e.g. wide intersection or rising gradient).</p> <p>Can be implemented without creating additional delays for other road users.</p> <p>As this reduces the bicycle green time, it should be ensured that the combined green plus intergreen time is sufficient for a cyclist accelerating from rest at the stop line to clear the controlled area.</p> <p>Requires bicycle display aspects at traffic signals.</p> <p>May result in poor compliance and a lack of respect for the bicycle signal aspect, as displaying a green vehicle signal aspect and red bicycle signal aspect may present a conflicting message to cyclists.</p>
Signal coordination	<p>In some situations, traffic signals coordination may be provided for the benefit of cyclists (refer to Section 7.7 of GTM 9).</p> <p>May be considered in specific situations such as on bicycle routes with high cyclist volumes, several closely spaced signals and a strong tidal flow.</p>
Scramble phase	<p>Allows all cyclist movements, including diagonal movements, to operate simultaneously within the marked limits of a crossing while eliminating vehicle conflicts.</p> <p>Should only be installed where there is demonstrated need for cyclists to cross diagonally.</p> <p>May be less appropriate for cyclists (than pedestrians) as cyclists may not easily filter without clearly defined pathways.</p> <p>Scramble crossing phases should operate full time.</p> <p>Needs to consider the delay impact for road users.</p>

Source: Austroads (2014c) Table 7.7.

10. Construction and Maintenance Considerations at Cycling Facilities





10.1 General

If bicycle paths or on-road facilities are not adequately constructed and maintained, cyclists are not likely to use them, or may swerve in order to avoid surface irregularities thus creating a hazardous situation. The importance of maintenance in relation to cyclist safety is referred to throughout GRD 6A and Section 12 and Appendix B of that Guide provide information on construction and maintenance considerations. Key Austroads guidance related to construction and maintenance considerations for cycling facilities is summarised in Table 10.1.

Table 10.1: Key cross-references related to construction and maintenance

Section of <i>Cycling Aspects of Austroads Guides</i>					
Guide	Section	Reference source	Guide	Section	Reference source
Section 10.1: General					
	Section 12 Appendix B	Austroads (2009f)			
Section 10.2: Pavements for Cycling (also Section 3.3 and Appendix E4)					
	Appendix B.4	Austroads (2009f)		General	Austroads Guides
Section 10.3: Maintaining Cycling Facilities (also Appendices E, F and G)					
	Section 7.7	Austroads (2010c)		Appendices B.1, B.2 and B.3	Austroads (2009f)
	General	Austroads (2009h)		General	Austroads Guides
	General	Austroads Guides			

Notes:

	Guide to Road Design (GRD)		Guide to Pavement Technology (GPT)		Guide to Project Delivery (GPD)
	Guide to Asset Management (GAM)		Guide to Road Safety (GRS)		

10.2 Pavements for Cycling

Smooth, debris-free surfaces are a fundamental requirement for riding bicycles in safety on paths and roads. As cyclists ride at speeds up to 50 km/h on downhill grades, a rough surface or pothole can cause a cyclist to fall, leave the path or road and crash or come into conflict with other path or road users. On uphill grades on roads, the speed differential between cyclists and motor traffic is greater and hence cyclists are exposed to potential conflict with motor traffic for a relatively long time as they manoeuvre around poor surfacing.

Most bicycles have no suspension or shock absorbers and many bicycles have relatively thin tyres inflated to high pressures. Consequently, when a cyclist hits a pothole at speed it is uncomfortable, difficult to maintain control and potentially hazardous for the cyclist.

Surface irregularities which are not noticeable in a motor vehicle can make cycling unpleasant and slow down the travel speed considerably. In order to gain an appreciation of the problems faced by cyclists with respect to maintenance it is suggested that road maintenance supervisors should ride a bicycle over sections of paths and roads used by cyclists. This enables a more detailed examination of the surface to be made including problems that are easily missed from a patrol motor vehicle. Further guidance on pavements for cycling is provided in Appendix E and the *Guide to Pavement Technology*.

10.3 Maintaining Cycling Facilities

A substantial capital investment is often made in providing cycling facilities and jurisdictions and road authorities should have an effective management regime to define responsibilities and to ensure that these facilities are adequately maintained.

Reference should be made to Appendix E of this document regarding construction and maintenance considerations for cyclists including:

- maintenance requirements
- provision for cyclists at work sites
- pavements and surfacing
- quality systems.

10.3.1 Bicycle Safety Audits

An important aspect of quality systems is bicycle safety audits. Bicycle safety audits are as important as safety audits that relate to other road users and should also comply with guidelines presented in GRS 6.

Bicycle safety audits should be applied to both on-road and off-road facilities, existing and proposed facilities, and all stages of the development of proposals from feasibility studies to pre-opening of the facility. An example of a bicycle safety checklist is provided in Appendix F of this document. Such lists should be used in conjunction with Austroads lists that relate to road design, transportation and traffic in general. An example of a bicycle safety audit is provided in Appendix G of this document.

10.3.2 Further Guidance

Asset management plays a key role in managing and maintaining cycling facilities. For further guidance on this topic, practitioners are referred to the *Guide to Asset Management*.

Practitioners are also referred to the *Guide to Project Delivery* for further guidance on project delivery in relation to the asset function and strategic planning process.







11. Bicycle Parking and End-of-trip Facilities

11.1 General

It is important that adequate facilities are provided at common destinations of bicycle trips. The facilities that are necessary include showers, lockers to store clothing and cycling equipment, and convenient and secure bicycle parking facilities.

GTM 11 is the primary cross-reference for this section. Table 11.1 summarises key Austroads guidance related to cyclist parking and end-of-trip facilities

Table 11.1: Key cross-references related to bicycle parking and end-of-trip facilities

Section of <i>Cycling Aspects of Austroads Guides</i>					
Guide	Section	Reference source	Guide	Section	Reference source
Section 11.2: Bicycle Parking (also Appendix H)					
	Sections 3.2.1 and 6.8.5 Commentary 2.2 and 9	Austroads (2008b)			
Section 11.3: On-street Bicycle Parking					
	Section 7.8.5	Austroads (2008b)			
Section 11.4: Types of Parking Devices					
	Commentary 9	Austroads (2008b)			
Section 11.5: Signs and Markings Showing Location and Purpose of Parking Facilities					
	Commentary 9	Austroads (2008b)			
Section 11.6: Showers, Lockers and Security					
	Section 4.6.9	Austroads (2014a)		Section 3.8.4	Austroads (2009a)
	Section 11.3	Austroads (2008b)			

Note:

 Guide to Traffic Management (GTM)

11.2 Bicycle Parking

11.2.1 General

Bicycle parking requirements are discussed in GTM 11 (Austroads 2008b), some of which are presented in this section.

Parking for cyclists falls into three categories:

- all-day parking at trip destinations (e.g. for employees and students)
- all-day/part-day parking at public transport stations or interchanges
- short-term parking at shopping centres, offices and other institutions.

Each category and site will have different requirements. GTM 11 provides comprehensive information on parking and includes guidance on bicycle parking facilities. However, bicycle parking facilities should also be designed in accordance with GTM 11, AS 2890.3-1993 and Transit New Zealand (2008) as appropriate.

Planning codes and policies in various jurisdictions may contain certain mandatory requirements for bicycle parking and other end-of-trip facilities such as showers and lockers in new developments. These facilities may also be installed as a result of the outcomes of local strategic bicycle plans, urban planning strategies or based on specific needs (Section 6.8.3, GTM 11, Austroads 2008b).

An indication of the levels of bicycle parking needed for various land uses is shown in Commentary 2.2 of GTM 11 and Appendix H of this document.

When considering the provision of new or modified car parking arrangements, practitioners should also consider the needs for additional facilities for cycling as well as the methods to minimise the impact of car parking on existing or future cycling use. This would normally include consideration of any strategic bicycle plan for the affected road(s) and, where practicable, ensuring good visibility for drivers including designing the layout of parking areas in such a way so as to reduce the chance of car doors being opened into the path of oncoming cyclists.

11.2.2 General Requirements of Devices

In general, every bicycle parking facility should:

- enable wheels and frame to be locked to the device without damaging the bicycle
- be placed in view of staff, customers and passers-by or covered by TV cameras
- be located outside pedestrian movement paths, segregated where possible, and possibly allowing extra footpath width in anticipation of cycles chained to poles
- be easily accessible from the road
- be arranged so that parking entries and exits will not damage adjacent vehicles
- be protected from manoeuvring motor vehicles and opening car doors
- be as close as possible to the cyclist's ultimate destination
- be well lit by appropriate new or existing lighting
- be protected from the weather
- be attractive and designed to blend in with the surrounding environment
- be appropriately signed
- be well maintained and kept free from graffiti: it should be noted that recurring maintenance costs should receive as much consideration in budgeting as the initial construction and installation costs
- have a convenient cut-down crossing (pram/kerb ramp) near the bicycle parking facilities.

Monitoring of demand/use should be carried out regularly in order to determine the effectiveness of the end-of-trip facility.

11.2.3 Location of Bicycle Parking Facilities

Bicycle parking facilities should be provided in small clusters within 100 m of common commuting and recreational destinations of bicycle trips such as schools, shopping centres, railway stations, bus terminals/interchanges, work places, sports grounds, etc.

It should be noted that if parking facilities are not conveniently located, cyclists will ignore them and continue the disorderly practice of securing bicycles to nearby railings, posts, seats, parking meters, trees etc. In particular, short-term bicycle parking needs to be convenient if it is to be effective.

11.3 On-street Bicycle Parking

Bicycle parking along a street is generally provided in the form of bicycle rails (Section 11.4). These facilities should be located parallel to the kerb or footway unless a footpath extension is provided, and on both sides of the road where demand warrants it. The minimum clearances should be as follows (Section 7.8.5, GTM 11):

- The clearance between a parked bicycle and the edge of the roadway should be at least 600 mm or 1000 mm if the speed limit on the roadway is greater than 60 km/h.
- On a footpath, the minimum clearance for passage of pedestrians between a parked bicycle and any other obstruction is 1200 mm (unless specified otherwise by legislation) with a greater clearance needed when there are high volumes of pedestrians.

When considering the provision of new or modified car parking arrangements, practitioners should also consider the needs for additional facilities for cycling as well as the methods to minimise the impact of car parking on existing or future cycling use. This would normally include consideration of any strategic bicycle plan for the affected road(s), and, where practicable, ensuring good visibility for drivers including designing the layout of parking areas in such a way so as to reduce the chance of car doors being opened into the path of oncoming cyclists.

Examples of bicycle parking facilities are shown in Figure 11.1 and Figure 11.2.

Figure 11.1: Bicycle parking in main street shopping precinct (Hamilton, NZ)



Source: Austroads (2009a) Figure 2.2 and NZ Transport Agency.

Figure 11.2: Bicycle parking, Reddacliff Place, Brisbane CBD, Qld



Source: Austroads (2009a) Figure 4.2 and Queensland TMR.

11.4 Types of Parking Devices

General

Bicycle parking facilities are classified by security level as shown in Table 11.2.

Table 11.2: Classification of bicycle parking facilities

Class	Security level	Description	Duration of parking	Main user type
1	High	Fully enclosed individual locker.	All day and night.	Bike and ride commuters at railway and bus stations.
2	Medium	Lockable enclosure, shelter or compound fitted with class 3 facilities where cyclist is responsible for locking their bicycle within the communal enclosure.	All day.	Regular employees, students, regular bike and ride commuters.
3	Low	Bicycle rails or racks to which both the bicycle frame and wheels can be locked.	Short to medium term.	Shoppers, visitors, employees of workplaces where security supervision of the facility is provided.

Source: Austroads (2008b) Table C9 2, Commentary 9

Bicycle lockers

Bicycles lockers (Figure 11.3) offer the highest level of bicycle security currently available. They also have the added advantage that helmets and other gear can be securely stored along with the bicycle. Bicycle lockers restrict access to one user and are most effective in public places where there is a high risk of theft or vandalism. They are most commonly located at railway stations and bus terminals to encourage the use of multi-modal travel, as well as at apartments, residential complexes, and university residences. They should be situated in a well-lit area, and fabricated from corrosion-resistant materials if close to the sea.

It is important that the use of lockers is managed by an appropriate authority such as the managers of a shopping centre, major building, or railway station. They can either be rented to a single user for a period of time, or casual users can obtain a lock and key from the facility manager. It is also possible to manage lockers automatically with electronic access control similar to that used by some airport luggage lockers.

Figure 11.3: Example of bicycle lockers location at a bus terminal in Canberra



Source: Austroads (2008b), Table C9 1, Commentary 9.

Bicycle enclosures

Bicycle enclosures offer a medium level of security in that while the owner can lock the bicycle within the enclosure, other users also have access to the enclosure. These are usually located at railway stations, public transport terminals, workplaces, universities/TAFE colleges, schools, apartments/residential complexes and university residences. Enclosures can be a room, a compound, or a purpose-built area containing groups of bicycle parking rails, and fitted with a roof for increased security and weather protection. Public lighting is desirable where they are located in a public place and used after dark.

Enclosures should be lockable to prevent unauthorised access. If restricted keys are used, unauthorised copying will be prevented. Electronic access control may also be suitable particularly if the building already has such a system. It is important to ensure that a nominated person is responsible for managing access issues and distributing keys or access cards to the enclosure. If a higher level of security is required, it may be possible to install a surveillance camera to monitor the door to the enclosure.

Where space is limited, an enclosure designed for vertical bicycle storage may be provided.

Bicycle parking rails

The parking rail is amongst the most versatile methods of bicycle parking currently available in that it is:

- inexpensive to install and maintain
- easily fabricated
- able to be located close to cyclist destinations
- suited to short and medium-term parking.

Parking rails are usually located at shopping centres/markets, business districts, recreational centres/swimming pools, libraries and universities/TAFE colleges. They should be located in well-lit areas in public view, where they will not impede the opening of doors on parked cars, and where they can also be easily seen by motorists. Where possible they should be situated near buildings that have on-site security or if a high level of security is required, it may be possible to install a surveillance camera to monitor the rails.

Parking rails may come in a number of shapes and sizes and can be as ornate as the site requires as long as the rail:

- supports the entire bicycle
- is of a shape that allows the cyclist to lock the front wheel and frame, top bar and back wheel and frame to the rail
- is manufactured from smooth steel tubing of a diameter that a u-lock can easily fit around (usually 50 mm) and is vandal resistant
- has base plates welded to the bottom of each leg so that they can be bolted to a concrete surface or long enough so they can be set in concrete footings.

Parking rails can be arranged to best fit the available space. Each parking rail can accommodate two bicycles, one on each side of the rail. They can also be installed in clusters or groups to meet the parking demand. Bicycle racks may also incorporate plastic coated chains which can be secured by padlock.

The traditional 'toaster rack' style bicycle stands holding only one wheel have been around for a long time. They do not, however, meet the requirements of AS 2890.3-1993 as they do not allow the frame and wheels to be locked to the rack, and can therefore damage the wheels. They should be replaced progressively giving priority to those where the security risk is greatest.

11.5 Signs and Markings Showing Location and Purpose of Parking Facilities

Information signs and pavement markings should be provided to direct cyclists to parking facilities and indicate the purpose of the facility in order to encourage their use. Lockers and other facilities must also display instructions for use.

Signs should be provided in accordance with AS 2890.3-1993, consisting of a standard bicycle pavement symbol with an additional panel below. The message on the lower panel should normally read Bicycle lockers, Parking enclosure, Parking rails or Parking. Another message may be required in special circumstances.

It is also recommended that bicycle rails have a small bicycle pavement symbol painted on the pavement beneath to clarify the purpose of the rails or have the words 'Bicycle Parking' stencilled on the rail. This is usually applicable to ornate rails that may be mistaken for street art.

11.6 Showers, Lockers and Security

In order to make bicycle trips in excess of five kilometres attractive to people it is necessary that clean, functional, secure showers and changing facilities be provided in the workplace. There is limited information on these facilities in the Austroads Guides; however, the need for them is recognised in several Guides.

Section 3.8.4 of GTM 7 provides guidance in relation to traffic management in activity centres states in relation to workplace parking that this is all-day use on a regular basis and can be expected to be combined with end-of-trip facilities such as showers, lockers etc. Demand for such parking is more likely to justify grouping of racks, often within areas where there is controlled access, such as in basement car parks, CCTV and casual monitoring by security staff. Individual bicycle lockers may be appropriate.

Section 4.6.9 of GTM 4 advises that all-day parking should provide a high level of security to prevent others from tampering with the bicycle, or stealing the bicycle or parts of it. Long-term parking therefore involves the provision of personal bicycle lockers, cages, or compounds ideally not more than 100 m from the destination. Cages and compounds should not only have a locked gate but also provide for the frame and both wheels to be locked to a rail within the enclosure.

GTM 11 provides considerable reference to lockers in combination with bicycle parking facilities that is summarised in Section 11.4.

References

- AASHTO 1991, *Guide for the development of bicycle facilities*, American Association of State Highway and Transportation Officials, Washington, DC, USA.
- Australian Bicycle Council n.d., *Australian Bicycle Council website*, ABC, Sydney, NSW, viewed 8 February 2013, <www.bicyclecouncil.com.au>.
- Australian Bicycle Council 2000, *Cycling data and indicator guidelines*, ABC, Sydney, NSW, viewed 8 February 2013, <<http://www.austroads.com.au/abc/images/pdf/guidelinesandindicators1.pdf>>.
- Australian Transport Council 2006, *National guidelines for transport system management*, 2nd edn, ATC, Canberra, ACT.
- Australian Transport Council 2011, *National road safety strategy 2011 – 2020*, ATC, Canberra, ACT.
- Austroads 2005, *The Australian national cycling strategy 2005 – 2010*, AP-C85-05, Austroads, Sydney, NSW.
- Austroads 2006a, *Guide to project evaluation: part 8: examples*, AGPE08-06, Austroads, Sydney, NSW.
- Austroads 2006b, *Pedestrian-cyclist conflict minimisation on shared paths and footpaths*, AP-R287-06, Austroads, Sydney, NSW.
- Austroads 2008a, *Guide to traffic management: part 8: local area traffic management*, AGTM08-08, Austroads, Sydney, NSW.
- Austroads 2008b, *Guide to traffic management: part 11: parking*, AGTM11-08, Austroads, Sydney, NSW.
- Austroads 2009a, *Guide to traffic management: part 7: traffic management in activity centres*, AGTM07-09, Austroads, Sydney, NSW.
- Austroads 2009b, *Guide to traffic management: part 10: traffic control and communication devices*, AGTM10-09, Austroads, Sydney, NSW.
- Austroads 2009c, *Guide to traffic management: part 12: traffic impacts of development*, AGTM12-09, Austroads, Sydney, NSW.
- Austroads 2009d, *Guide to road design: part 4: intersections and crossings: general*, AGRD04-09, Austroads, Sydney, NSW.
- Austroads 2009e, *Guide to road design: part 4C: interchanges*, AGRD04C-09, Austroads, Sydney, NSW.
- Austroads 2009f, *Guide to road design: part 6A: pedestrian and cyclist paths*, AGRD06A-09, Austroads, Sydney, NSW.
- Austroads 2009g, *Guide to road design part 6B: roadside environment*, AGRD06B-09, Austroads, Sydney, NSW.
- Austroads 2009h, *Guide to road safety: part 6: road safety audit*, 3rd edn, AGRS06-09, Austroads, Sydney, NSW.
- Austroads 2009i, *Guide to road transport planning*, AGRTP-09, Austroads, Sydney, NSW.
- Austroads 2009j, *Guide to road safety: part 4: local government and community road safety*, AGRS04-09, Austroads, Sydney, NSW.
- Austroads 2009k, *Guide to traffic management: part 13: road environment safety*, AGTM13-09, Austroads, Sydney, NSW.
- Austroads 2009l, *Guide to road safety: part 8: treatment of crash locations*, AGRS08-09, Austroads, Sydney, NSW.
- Austroads 2010a, *Guide to road design: part 4A: unsignalised and signalised intersections*, AGRD04A-10, Austroads, Sydney, NSW.
- Austroads 2010b, *Guide to road design: part 3: geometric design*, AGRD03-10, Austroads, Sydney, NSW.
- Austroads 2010c, *Guide to road design: part 6: roadside design, safety and barriers*, AGRD06-10, Austroads, Sydney, NSW.
- Austroads 2010d, *The Australian national cycling strategy, 2011-2016*, AP-C85-10, Austroads, Sydney, NSW.

- Austroads 2011a, *Australian cycling participation 2011*, AP-C91-11, Austroads, Sydney, NSW.
- Austroads 2011b, *Guide to road design: part 4B: roundabouts*, AGRD08-11, Austroads, Sydney, NSW.
- Austroads 2011c, *Effectiveness and selection of treatments for cyclists at signalised intersections*, AP-R380-11, Austroads, Sydney, NSW.
- Austroads 2013a, *Guide to road safety: part 1: road safety overview*, 3rd edn, AGRS01-13, Austroads, Sydney, NSW.
- Austroads 2013b, *Guide to traffic management: part 3: traffic studies and analysis*, 2nd edn, AGTM03-13, Austroads, Sydney, NSW.
- Austroads 2013c, *Guide to traffic management: part 6: intersections, interchanges and crossings*, 2nd edn, AGTM06-13, Austroads, Sydney, NSW.
- Austroads 2013d, *Guide to road design: part 5: drainage – general and hydrology considerations*, AGRD05-13, Austroads, Sydney, NSW.
- Austroads 2013e, *Guide to road design: part 5A: drainage – road surface, network, basins and subsurface*, AGRD05A-13, Austroads, Sydney, NSW.
- Austroads 2014a, *Guide to traffic management: part 4: network management*, AGTM04-14, Austroads, Sydney, NSW.
- Austroads 2014b, *Guide to traffic management: part 5: road management*, AGTM05-14, Austroads, Sydney, NSW.
- Austroads 2014c, *Guide to traffic management: part 9: traffic operations*, AGTM09-14, Austroads, Sydney, NSW.
- Bicycle Federation of Australia 2007, *Bikeability toolkit*, TravelSmart, Canberra, ACT, viewed 8 February 2013, <www.travelsmart.gov.au/bikeability/pubs/briefchecklist.pdf>.
- Bovy, PHL & Bradley, MA 1985, 'Route choice analysed with stated-preference approaches', *Transportation Research Record*, no. 1037, pp.11-20.
- Bureau of Transport Statistics 2012, *2010/11 Sydney household travel survey: summary report 2012 release*, BTS, Sydney, NSW.
- Cement and Concrete Association of Australia 1997, 'Rider comfortable concrete dual use pathways: a practical guide for the construction supervisor', Cement and Concrete Association of Australia, Sydney, NSW.
- California Department of Transportation 2006, 'Bikeway planning and design', in *California highway design manual*, Caltrans, Sacramento, CA, USA.
- Cluster for Physical Activity and Health 2007, *Walkability and bikeability checklists*, Centre for Physical Activity and Health, University of Sydney, NSW, viewed 8 May 2013, <www.cpah.health.usyd.edu.au/research/walk.php>.
- Department of Infrastructure, Planning and Natural Resources 2004, *Planning guidelines for walking and cycling*, DIPNR, Sydney, NSW, viewed 8 February 2013, <www.planning.nsw.gov.au/plansforaction/pdf/guide_pages.pdf>.
- Department of Transport 2009, *Victorian integrated survey of travel and activity 2007 (VISTA 07)*, DOT, Melbourne, Vic.
- Department of Urban Affairs and Planning 2001, *Integrating land use and transport: improving transport choice: guidelines for planning and development*, DUAP, Sydney, NSW, viewed 8 February 2013, <www.planning.nsw.gov.au/programservices/pdf/prg_transport.pdf>.
- Global Road Safety Partnership 2008, *Speed management: a road safety manual for decision-makers and practitioners*, Global Road Safety Partnership, Geneva, Switzerland.
- Ker, IR 2004, 'Perth bicycle network, stage 3: 2004', contract report RE5156, ARRB Transport Research, Vermont South, Vic.
- Khan, SI & Raksuntorn, W 2001, 'Accuracy of numerical rectification of video images to analyze bicycle traffic scenes', *Transportation Research Record*, no. 1773, pp. 32-8.
- Land Transport New Zealand 2007, *Pedestrian planning and design guide*, Land Transport New Zealand, Wellington, NZ, viewed 26 November 2013, <<http://www.nzta.govt.nz/resources/pedestrian-planning-guide/>>.
- Luk, JYK & Yang, C 2001, 'Impact of ITS measures on public transport: a case study', *Journal of Advanced Transportation*, vol. 35, no. 3, pp. 303-20.

- Ministry of Transport 2005, *Getting there: on foot, by cycle: a strategy to advance walking and cycling in New Zealand transport*, Ministry of Transport, Wellington, New Zealand.
- Ministry of Transport 2006, *Getting there: on foot, by cycle: strategic implementation plan 2006 – 2009*, Ministry of Transport, Wellington, New Zealand.
- Ministry of Transport 2008, *New Zealand transport strategy 2008*, Ministry of Transport, Wellington, New Zealand.
- Ministry of Transport 2010, *Safer journeys: New Zealand's road safety strategy 2010 – 2020*, Ministry of Transport, Wellington, New Zealand.
- NZ Transport Agency 2010a, *Manual of traffic signs and markings (MOTSAM): part 1: traffic signs*, NZTA, Wellington, New Zealand, viewed 15 March 2013, <www.nzta.govt.nz/resources/motsam/part-1/>.
- NZ Transport Agency 2010b, *Manual of traffic signs and markings (MOTSAM): part 2: markings*, NZTA, Wellington, New Zealand, viewed 15 March 2013, <www.nzta.govt.nz/resources/motsam/part-2/>.
- Ove Arup and Partners 1989, *Urban freeway cycling study*, prepared for Road Construction Authority (Victoria) & Roads and Traffic Authority (NSW), Ove Arup and Partners, Melbourne, Vic.
- Pedestrian and Bicycle Information Center 2008, *Bikeability checklist: how bikeable is your community?* Pedestrian and Bicycle Information Center & National Highway Traffic Safety Administration, Department of Transportation, Washington, DC, USA, viewed 8 May 2013, <<http://www.bicyclinginfo.org/pdf/bikabilitychecklist.pdf>>.
- Richardson, AJ, Ampt, ES & Meyburg, AH 1995, *Survey methods for transport planning*, Eucalyptus Press, Melbourne, Vic.
- Roads and Traffic Authority 2005, *NSW bicycle guidelines*, version 1.2, RTA, Sydney, NSW, viewed 8 February 2013, <www.bicycleinfo.nsw.gov.au/downloads/nswbicycleguidelines_12a_i.pdf>.
- Stopher, P 2011, 'Evaluation of GPS device properties for a possible use in future household travel surveys', *Transportation Research Board annual meeting, 90th, 2011, Washington, DC*, TRB, Washington, DC, USA, 14 pp.
- Transit New Zealand 2008, *New Zealand supplement to the Austroads guide to traffic engineering practice, part 14: bicycles*, SP/M/025, Transit New Zealand, Wellington, NZ, viewed 19 November 2013, <<http://www.nzta.govt.nz/resources/nz-supplement-austroads-gtep-part-14-bicycles/>>.
- VicRoads 1999, *Cycle notes, no. 4: clearway bicycle lanes*, VicRoads, Kew, Vic, viewed 16 September 2013, <www.vicroads.vic.gov.au/NR/rdonlyres/FFA0385D-FC4E-43DC-9A29-02F4A624E60C/0/tr1998018.pdf>.
- VicRoads 2005, *Cycle notes no. 15: providing for cyclists at roundabouts*, VicRoads, Kew, Vic, viewed 16 September 2013, <www.vicroads.vic.gov.au/NR/rdonlyres/0058B74B-AEA5-42BC-80DE-1FAC294FD371/0/TR2005253v2.pdf>.
- VicRoads 2011, *Traffic engineering manual: volume 2: signs and markings: chapter 16*, VicRoads, Kew, Vic.
- Webster, DC & Layfield, RE 1998, *Traffic calming: sinusoidal, 'H' and 'S' humps*, TRL report 377, Transport Research Laboratories, Crowthorne, UK.
- Yeates, M 2000a, 'Road safety: for all users?', *Road safety, research, policing and education conference, 2000, Brisbane, Queensland*, Centre for Accident Research and Technology, Queensland University of Technology, Brisbane, Qld, pp. 87-92.
- Yeates, M 2000b, 'Making space for cyclists by sharing the road: Brisbane City Council's 'Bicycle Friendly Zones'', *Safe cycling conference, 2000, Brisbane, Queensland*, Department of Transport, Brisbane, Qld, 8 pp.

Austroads Guides

Guide to project evaluation: parts 1-8.

Guide to asset management: parts 1-8.

Guide to road design: parts 1-8.

Guide to pavement technology: parts 1-10.

Guide to road safety: parts 1-9.

Guide to project delivery: parts 1-4.

Guide to traffic management: parts 1-13.

Guide to bridge technology: parts 1-7.

Guide to road tunnels: parts 1-3.

Australian and New Zealand Standards

AS/NZS 1158.3.1-2005, Lighting for roads and public spaces: pedestrian area (category P) lighting: performance and design requirements.

AS/NZS 1428.4.1-2009, Design for access and mobility: means to assist the orientation of people with vision impairment: tactile ground surface indicators.

AS 1742.2-2009, Manual of uniform traffic control devices: traffic control devices for general use.

AS 1742.3-2009, Manual of uniform traffic control devices: *traffic control for works on roads*.

AS 1742.7-2007, Manual of uniform traffic control devices: railway crossings.

AS 1742.9-2000, Manual of uniform traffic control devices: bicycle facilities.

AS 1742.10-2009, Manual of uniform traffic control devices: pedestrian control and protection.

AS 2890.3-1993, Parking facilities: bicycle parking facilities.

AS 5100 Set-2007, *Bridge design set*.

Appendix A Bicycle Network Evaluation Example

A.1 General

The Austroads *Guide to Project Evaluation* provides guidance on how evaluation should be carried out. For additional guidance, practitioners are also referred to the *National Guidelines for Transport System Management in Australia* (Australian Transport Council 2006). The Australian Bicycle Council website (Appendix B, www.bicyclecouncil.com.au) also provides a number of examples of the evaluation of cycling.

This example is taken from Section 3.10 of the *Guide to Project Evaluation – Part 8: Examples* (Austroads 2006a) and is a direct adaptation from a Perth bicycle network evaluation project (Ker 2004). The program that is the subject of evaluation in this example consists of the following components of the Perth bicycle network to be funded over five years:

- principal shared paths – \$37.35 million
- train station precinct projects – \$1.6 million
- local bicycle routes – \$15 million (including \$7.5 million local government)
- cycling infrastructure grants – \$15 million (including \$5 million local government)
- regional recreational paths – \$8 million (including \$4 million local government).

Cycling is an environmentally-friendly mode of transport for a number of trips for which it can be a good substitute for car use. Cycling generates no significant negative externalities, especially when bicycle infrastructure that minimises conflict with motor vehicles is available.

A cycling benefits assessment framework that was developed by the Perth project (Ker 2004) to evaluate the effects of cycling substituting for car travel is summarised below. The methodology used describes the following steps:

- estimate benefits for each cycle-km generated (i.e. new) and diverted (from other routes) as shown in Table A 1
- estimate usage of new facility and convert to cycle-km, taking care to relate to existing trend (e.g. if cycle use is generally increasing, then some part of the facility usage would have been expected even without the facility) and distinguishing between new trips and diverted trips
- estimate capital and maintenance costs of the new facility
- discount values to base year to calculate net worth of project.

Table A 1 shows the values used to calculate the benefit per kilometre of car travel transferred to bicycle.

As shown in Table A 1 the direct financial benefits to the user (i.e. the person who previously travelled by car) are equivalent to 19.7 cents per kilometre. These are based only on the savings in variable running costs for a car. Some households might decide that they are then able to do without a second car, in which case there would be additional fixed-cost savings (vehicle registration, depreciation, interest on capital), but no account has been taken of this possibility, as in these circumstances it would be likely that other changes in travel behaviour would be made and a simple benefit-cost evaluation would be of limited use. This benefit is only offset to a small extent (3.6 cents/km) by the cost of owning and operating a bicycle (Table A 1).

The socio-economic benefits are calculated to be substantially higher than the individual's financial benefits, and are greater in the peak than the off-peak traffic period. Within this overall value, there is only one negative (other than the cost of owning and operating a bicycle) and that is the increase in cyclist road trauma, but this is more than offset by the health and fitness benefits.

Table A 1: Benefit values per kilometre reduction in car travel (2004 prices)

Item of benefit	Value (cents/km)	
	Peak	Off-peak
Financial benefit to individual		
Private vehicle operating costs	19.7	19.7
Cycle user cost (increase)	(3.6)	(3.6)
Socio-economic benefits		
Private vehicle operating costs (net of tax) ⁽¹⁾	12.9	12.9
Cycling user cost	(3.3)	(3.3)
Road trauma (increased cycling)	(14.6)	(14.6)
Road trauma (cycling diverted to PSPs) ⁽²⁾	14.6	14.6
Road trauma (reduced car use)	5.2	5.2
Road traffic congestion	15.8	3.2
Air pollution costs to community	3.6	2.7
Greenhouse gas emissions	1.2	1.2
Improved health and fitness due to exercise	17.2–34.4	17.2–34.4
Traffic noise ⁽¹⁾	3.6	0.7
Water pollution ⁽¹⁾	2.4	2.4
Social impacts ⁽¹⁾	Not quantified	Not quantified
TOTAL per new cycle trip-km	61.2	44.8
TOTAL per existing cycle trip diverted to PSP	14.6	14.6

1 Based on current traffic conditions. All studies indicate that traffic volume will increase relative to road capacity and hence congestion, vehicle operating costs, exhaust emissions and associated impacts will increase. In the case of exhaust emissions and greenhouse gas emissions, technological improvements (e.g. use of cleaner fuels) may offset this to some extent.

2 PSP denotes Principal Shared Path.

Source: Austroads (2006a) Table 3.2.

A.2 Impact of Cycle Use

Counts of cyclist numbers across Perth have been undertaken annually since 1998. Counts at all sites showed an 84% (13% per year) increase between 1999 and 2004. This demonstrates the effectiveness of the Perth Bicycle Network, along with other initiatives, in increasing cycle use in key areas. Screenline counts in the East Perth/Highgate area indicate that the opening of the Principal Shared Paths (PSP) along the railway between Maylands and East Perth resulted in substantial increases in cycle trips from 2002 to 2004. The net trip generation of the PSP has been around 600 trips per weekday (3000 per week), with around 100 trips per day (500 per week) gaining the benefit of a substantially safer cycling environment by transferring from other routes to the PSP. The net trip generation of the PSP has been around 207 000 per year, with around 35 000 gaining the benefit of a substantially safer cycling environment by transferring from other routes to the PSP.

A.3 Benefit-cost Evaluation

A conventional benefit-cost analysis framework was then applied to the PSP component of Stage 3 of the Perth Bicycle Network. For evaluation purposes, it was assumed that:

- Each km of PSP constructed will generate and attract cycle trips at the same rate as the Maylands-East Perth PSP (which was 2.9 km).
- Trip lengths will be substantially longer than the average cycle trip length of 2.25 km, as this figure includes a high proportion of purely local trips not served by PSPs. It was assumed that the average cycle trip length is 6.1 km, in line with the average length of cycle trips generated by TravelSmart Individualised Marketing in Perth.

The results of this conventional project evaluation demonstrate a net present value (NPV) of \$75.6 million and a benefit-cost ratio of 3.3 for this project. These results have been obtained using a discount rate of 7% per annum over a 25 year project horizon, with no residual value assumed for the PSPs. The evaluation includes appropriate allowance for the maintenance costs of the PSPs under the WA Main Roads term network maintenance contracts.

A.3.1 Other Factors Affecting Level of Benefits

In addition to the level of cycle usage as identified above, the following factors will affect the actual benefits achieved by the PSP program:

- Level of path usage by pedestrians. Whilst walking trips are generally substantially shorter than cycle trips, the PSPs will attract walking activity. They are adjacent to rail lines and train stations, thus serving walk access to public transport, and also serve a number of activity centres (schools, shops, employment) along the way. These benefits will be additional to those estimated above.
- Concentrated promotion of new PSPs. Previous PSPs have not been given strong marketing in the area they serve. The proposed Stage 3 PSPs will be given concentrated marketing to potential users in the area. This will increase the levels of use beyond those observed for previous PSPs and, hence, those used as the basis of this evaluation.
- The extent to which cycle trips replace trips other than car driver. The evaluation has been based on all new cycle trips being converted from car driver trips (i.e. each cycle trip means one less car on the road). In practice, there may be some substitution from other modes, although this is least likely for walk (as walk trips are short) and public transport (as the main 'competition' is with rail (for which trips are longer than average, so more likely to be beyond typical cycling distance – in 1986 (the most recent travel survey data available for Perth) only 14% of train trips were less than 5 km and 30% less than 10 km).
- That leaves car passenger trips, a proportion of which (including driving children to and from school and other activities) are undertaken solely for the benefit of the passenger and involve two car trips (there and back) for each passenger trip. For those previous car passenger trips where the driver still has to travel, this evaluation will overstate the benefits of the substitute cycle trip, as the car will still be on the road for the same amount of time. However, for those where the driver no longer has to travel, the evaluation will understate the benefits by a factor of two, as two car trips are removed for each cycle trip.
- Given that car occupancy rates in Perth are low (around 1.2, on average) and around 40% of car passenger trips are for education (mainly school) purposes, the net impact of substitution for car passenger, rather than car driver trips is likely to be small.

Overall, it is likely that the factors indicating that the evaluation will underestimate benefits, including the pre-existing declining trend in cycle usage, will outweigh any factors leading to overestimation.

A.4 An Overview of this Bicycle Example

The PSP component of the proposed Stage 3 of the Perth Bicycle Network has been demonstrated to generate user and community benefits in excess of the costs of building the facilities. A benefit-cost evaluation, using conventional transport project assessment methodology has calculated a project NPV of \$75.6 million and a BCR of 3.3.

This is likely to be a conservative value as it takes no account of the additional usage likely to be generated by the extension of an incomplete network of facilities, including some missing links that will greatly enhance the range of destinations it serves.

Other components of the investment proposal are for much lower-cost facilities, including local bicycle routes and other local, rather than regional, bicycle facilities. The general increase in cyclist numbers at sites surveyed since 1998–99, especially those on local bicycle routes, is sufficient to justify the investment, given the substantially lower cost of these facilities.

Regional recreation paths, in particular, will also generate substantial levels of recreational walking activity, which has been acknowledged to be highly beneficial in relation to health outcomes.

Public sector proposals are increasingly required to be assessed against the triple bottom line criteria of economic, environmental and social impacts. The Perth Bicycle Network proposal demonstrates a positive outcome on:

- financial/economic outcomes, primarily through savings in car operating costs and congestion costs
- the environmental bottom line, through reductions in air pollution, water pollution and greenhouse gas emissions
- the social bottom line, through improvements in health and fitness that more than offset any net increase in road trauma.

Appendix B Australian Bicycle Council Website

The Australian Bicycle Council website (www.bicyclecouncil.com.au, Australian Bicycle Council n.d.) is an information hub for Australian transport and recreation cycling.

It is designed to provide high quality information to planners, engineers, academics, advocates with an interest in cycle planning and encouragement.

It provides supplemental information on many of the cycling topics discussed in this document and the Austroads Guides. Areas covered include:

- evaluation and monitoring
- engineering and planning
- education and training
- encouragement and promotion
- enforcement and road safety
- recreation and tourism
- funding.

Practitioners are referred to this website for supplemental guidance on cycling facilities and issues.

The site is administered by the Australian Bicycle Council with the operational support of Austroads.

Appendix C Bicycle Survey Methods

C.1 General

Bicycle survey methods are discussed in GTM 3 (Austroads 2013b), particularly Appendix E, from which the following information is sourced.

C.2 Manual Bicycle Counts

Manual counts consist of an observer recording the flow of cyclists past a certain point for the required time period. The most common method of collecting volume data is by manual counts of the flow of cyclists at a particular point in the traffic system. In the simplest form, the observer manually records the number of cyclists for the time period. The demands of data collection can be reduced by using mechanical, electrical or computerised tally counters.

Manual cyclist counts rely on good planning and skilled observers to ensure accurate and useful results. The number of observers will depend on the general level of traffic activity and the data-recording task. For example, if classification of cyclists (by demographic and/or direction of travel) is necessary, more observers will be required. Observation sites need to be chosen so that they provide a good view of the area but also provide protection from the weather and inquisitive people.

C.3 Questionnaire Surveys

Questionnaire surveys can provide useful information on route choice, origin-destination information, characteristics of cyclists, crash history and the adequacy of bicycling facilities. Questionnaires can be mail-back, self-administered or interviewer-administered. The mail-back questionnaire is useful when the respondent has little time to answer the questions. The response to such surveys, however, can be quite low (30%) and unless information on the characteristics of the non-respondents is known, the results could be misleading. Simple, readily understandable questions will provide the highest response rate. Self-administered questionnaires are completed by cyclists (or pedestrians) at the location where they are handed out. For this technique to be successful the respondent must be captive and not pushed for time. As with the mail-back survey, the questions must be simple and easily understood. The on-site interview involves an interviewer asking the cyclist (or pedestrian) a series of questions, and recording the answers. Again, the respondent must not be pressed for time and the questions asked should be kept to a minimum. The advantages of this technique are an increased response rate and the ability to further explain difficult questions.

Another form of questionnaire is the household or workplace survey. These types of surveys can be used to collect considerable information on trip purpose, route and origin-destination and socioeconomic characteristics. Household surveys are expensive to undertake, particularly on a random sample of the population because cycling is a relatively rare activity.

An important factor to keep in mind when preparing questionnaires is the use of appropriate definitions. For example, one problem area is the definition of a trip. A trip can be defined as a one-way movement of a person or vehicle between two points for a specific purpose.

C.4 Bicycle Detection

Inductive loop detectors are commonly used to detect vehicles but can also be used to detect bicycles. The loops, which are buried just below the surface of the road or cycle way record metallic objects passing over due to a change in the inductance. Bicycles have a lower metal content than vehicles. Bicycle inductive loop detectors therefore need to be more sensitive to produce acceptable results.

Piezo-detectors can also be used to detect bicycles. Piezo materials change electrical characteristics when subjected to mechanical deformation caused by pressure. The deformation can cause a change in resistance (piezo-resistive) or the generation of a charge (piezoelectric). The piezo-resistive sensor can detect a bicycle at low to zero speeds, whilst the piezoelectric sensor is not effective at very low speeds.

As with the detection of pedestrians, microwave, infra-red, ultrasonic and laser detection methods can also be used to detect bicycles. Again, these types of sensors may not provide the required accuracy due to difficulties in distinguishing between closely spaced bicycles.

C.5 Video

Video recordings can be analysed to determine bicycle flow rates, speeds and headways. The time stamp of the video including the frame number allows an accurate time recording. A technique by Khan and Raksuntorn (2001) automatically determines bicycle-flow data and could greatly simplify the study of bicycle-flow characteristics. The technique estimates bicycle location data by transforming screen coordinates of video frames to ground or roadway coordinates. The process is called rectification and enables automatic recognition of location and hence speed and acceleration data.

Further research is needed in this important area and imaging technologies are expected to continue to improve.

C.6 Travel Time and Delay Studies

Travel time and delay information can be collected via a number of methods including questionnaires, video with time-stamp facilities and tagging.

In a tagging survey, cyclists entering a study area are given a card showing the time of arrival, classification and entry point. This information is updated as they pass other tagging points. The cards are collected and stamped with appropriate time and location information at the exit points. The method can yield a large amount of data on trip patterns and travel times. For detailed route information the cards need to be marked at a number of locations. The delay involved in this marking could well influence the travel time measures. Cards may also be lost or discarded.

Delay information is also of interest to traffic professionals. The delay of cyclists can either be a delay determined at a point in the traffic system or the delay over a route. The *route delay* can be determined by subtracting the unimpeded travel time along a route from the observed travel time measured in the study. The unimpeded travel time is the average travel time for a sample of unimpeded cyclists. *Point delay* can be determined by observing the number of cyclists stopping and measuring the length of time they are stopped. In situations where there is a large queue and the delay at different points in time is required, it may be necessary to employ a large number of observers or use techniques that do not involve detailed observation of individual movements. Appendix C of GTM 3 (Austroads 2013b) provides further details on travel time and delay surveys, some of which can apply in bicycle studies.

C.7 Behaviour and Conflict Studies

The illegal use of traffic signals and other facilities and incidence of queue jumping could influence the effectiveness of a facility. Information on the proportion of cyclists not observing regulations and making illegal manoeuvres can be collected using manual observation of the system. Video recording may also help. The unusual nature of the movements recorded, however, precludes most automatic methods of data collection.

C.8 Data Analysis and Results

The Australian Bicycle Council (2000) released a set of guidelines on the reporting of cycling data, which was an initiative under the national cycling strategy (Austroads 2005). The guidelines provide a framework for the reporting of comparable state and territory data, so that relevant comparisons could be made. The development of the guidelines allowed the measurement of progress towards a goal of increased cycling participation. The guidelines cover the reporting of bicycle ownership, infrastructure, usage, demographics and safety.

The Council recommended that data be obtained from existing data sources such as those from Australian Bureau of Statistics population census and household travel surveys of capital cities. Surveys should also be undertaken in stages to collect the appropriate data, which included the following in the first stage:

- bicycle ownership per capita
- bicycle network coverage (urban)
- cycling mode share
- cycling trip purposes
- proportion of population cycling
- cyclists age and gender
- cyclist injury rates – hospital reported
- cyclist crash rates – police reported.

C.9 Future Development

The development of new technologies has already automated a number of tasks in bicycle studies, as was described above. In the near future, advancements to existing technologies and the development of new techniques should see a further simplification of study techniques by decreasing the manual component even more. These include:

- Global positioning system (GPS) – GPS receivers and loggers can currently be installed in vehicles to record route, speed and travel time information. Hand-held units could provide similar information about cyclists (Stopher 2011).
- Geographic information system (GIS) – in all the questionnaire and interview techniques discussed above there is an opportunity to ask respondents to mark their routes on a map of the locality. These routes can be entered into a GIS and the frequency of trips along a particular route can then be easily determined (Richardson et al. 1995).
- Video – further development of video capture and data processing technology should enable accurate automatic recording of bicycle flow, speed, congestion, route and origin-destination data.
- Smart card – non-contact smart card technology already exists for payment of public transport fares (Luk & Yang 2001). This technology could be adapted to provide data on bicycle flows, in a study similar to the tagging survey described in Appendix C.6 of this document.

Appendix D Human Powered Vehicles

Although the bicycle is the standard vehicle for the design of facilities, the use of tandem bicycles, tricycles and other 'pedal powered vehicles' may be popular in some areas and an allowance for these vehicles may be appropriate in the design of some facilities (refer to GRD 6A, Austroads 2009f).

There is limited information available on the needs, and operating characteristics of these vehicles, and in particular on their performance from the perspective of road and path design, or in relation to traffic management and safety. Therefore designers should make their own assessment of the required measures that need to be taken, accounting for the local use of these vehicles.

The aspects listed in Table D 1 may be relevant.

Table D 1: Human powered vehicle (HPV) – facility design considerations

Issue	Details
Sight distance	Consider low cyclist eye height (as low as 0.7 m above riding surface in some instances).
Braking performance	Due to factors such as the low centre of gravity and braking system, braking performance of a recumbent tricycle can be significantly more effective than a standard bicycle. Conversely, tandem bicycles may have a lesser performance.
Median or refuge width	Additional length of some HPVs may necessitate special consideration.
Turning paths	Refer to Table C 2.
Width (of road and path facilities)	Use vehicle design envelope equal to difference in inner and outer turning path radii, plus 0.3 m (0.4 m for tandem). If greater than bicycle design envelope width then increase path or road treatments accordingly.
Path terminals	Give due allowance for lesser turning capabilities and in particular avoid chicanes.
Speed	May be relatively high for tandem bicycles. May be lower for elderly cyclists, or cyclists with a disability.
Gradients	Path gradients may have to be flatter for elderly cyclists, or cyclists with a disability.
Education	Make available relevant advice e.g. conspicuity for low vehicles.

Source: Austroads (2009f) Table C2 1.

The following example vehicle dimensions may be helpful as a guide.

Table D 2: HPV dimensions

	Overall vehicle width (m)	Inner turning path radius (m)	Outer turning path radius (m)	Length (m)
Recumbent touring tricycle (Greenspeed)	0.9	1.4	2.3	1.95
Tandem recumbent touring tricycle (Greenspeed)	1.0	3.1	4.1	3.5
Tandem bicycle (Cannondale)	0.56	1.85	2.55	2.45
Bicycle with two wheel trailer (Coolstop)	0.82	0.7	1.85	2.67
Bicycle with BOB trailer (i.e. Beast of Burden)	0.56	0.9	1.6	2.8
Bicycle with hitch-bike (Thorogood)	0.56	1.7	2.55	1.7

Source: Austroads (2009f) Table C2 2.

Appendix E Construction and Maintenance

E.1 General

The material in this appendix is taken from Appendix B of GRD 6A.

Careful location, design and construction of paths for cycling can reduce future maintenance requirements. Careful attention to drainage, the location of vegetation and the type of vegetation planted can assist in minimising maintenance. A large amount of maintenance can be prevented if debris is not washed onto paths, if the roots of inappropriate plant species do not cause pavement damage and trimming of overhead branches is not required.

The path alignment and cross-section should be designed to minimise the amount of debris, which can wash onto the path surface. Paths adjacent to watercourses should be located so that the likelihood of inundation and the resulting slippery surface is reduced.

Bushes that will not grow tall enough to obstruct sight distance should be planted on the inside of curves. Trees should be chosen and planted away from the edge of paths so as to minimise the likelihood of roots causing deformation and cracking of the path surface.

Most authorities would be aware of the financial implications of failing to maintain roads, and yet it is not uncommon for paths to be substantially neglected after construction. Paths for bicycles should be included in asset management programs in a similar manner to roads, to provide a safer and useable riding surface and also to avoid the increasing cost of maintenance or reconstruction as a result of the asset degradation.

It is essential for effective maintenance operations that all aspects of the design allow for ease of access for all necessary maintenance plant (i.e. truck, backhoe, mowers), not only to the path but abutting reservations that do not have alternative access. As the construction may not be performed by the authority performing the maintenance, consultation should be undertaken throughout the design process in order to determine maintenance requirements.

E.2 Path Maintenance Requirements

Regular maintenance activities on paths should include:

- filling of cracks (Figure E 1)
- trimming or removal of grass so that it does not intrude into the path
- sweeping of paths to remove debris such as broken glass and fine gravel (including that arising from construction and maintenance activities such as crack sealing)
- re-painting of pavement markings
- cleaning of signs
- trimming of trees and shrubs to maintain safe clearances and sight distances.

Figure E 1: Asphalt paths requiring maintenance

(a)



(b)

Source: Austroads(2009f) Figures B.2 and B.3.

E.3 Provision at Works

When construction and maintenance work is carried out involving trenching or other construction work across roads and paths, access for cyclists (and pedestrians in the case of shared paths) should be maintained, and to a satisfactory quality to avoid the use of alternative routes which may be hazardous or inconvenient for cyclists (and pedestrians).

Construction and maintenance works should be undertaken in such a way that these activities do not place cyclists at risk during the works period. This is particularly important, for instance, where a sealed shoulder is closed for maintenance on freeways or other high speed roads where cyclists may be permitted.

Also, whilst different standards are sometimes applied to paths, it is worth noting that an open trench in a road is potentially no less hazardous than one that is adjacent to a well-used path.

E.3.1 Signing and Delineation at Work Sites on or Adjacent to Paths or On-road Facilities

The signing and delineation of construction and maintenance works on roads and footpaths should be performed in accordance with AS 1742.3 and any relevant local codes of practice and regulations. In general, provision for works on paths should be made in accordance with the principles of these standards. Additional consideration of cyclists should be made in accordance with the details set out below.

As a principal objective of provision for cyclists adjacent to the works site, the riding surface should be maintained in a clean and smooth state. This may necessitate sweeping of the riding surface on at least a daily basis.

Figure E 2, Figure E 3 and Figure E 4 highlight the desired level of provision required in the vicinity of works, depending on the circumstances. The actual provisions to be made are dependent on the conditions that exist, including:

- presence of a traffic controller
- existing level of bicycle use, and also of pedestrian use in the case of shared use path diversions
- available opportunities to provide for cyclists
- road or path alignment
- traffic speeds and volumes
- duration of work
- surface material and condition
- environmental impacts.

Figure E 2: Works on roads – exclusive bicycle path diversion

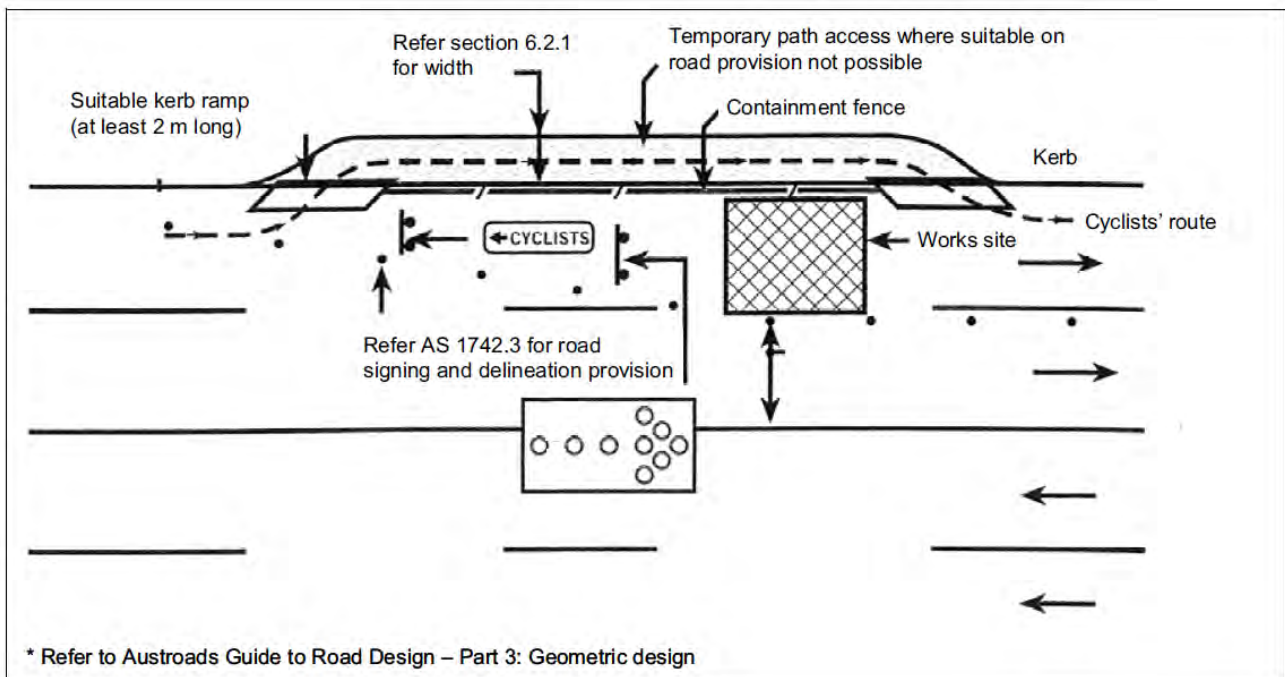

Note: For temporary path widths, refer to Section 6.2.1 of GRD 6A (Austroads 2009f).

Source: Austroads (2009f) Figure B 3.

Figure E 3: Works on paths adjacent to roads – shared use path diversion

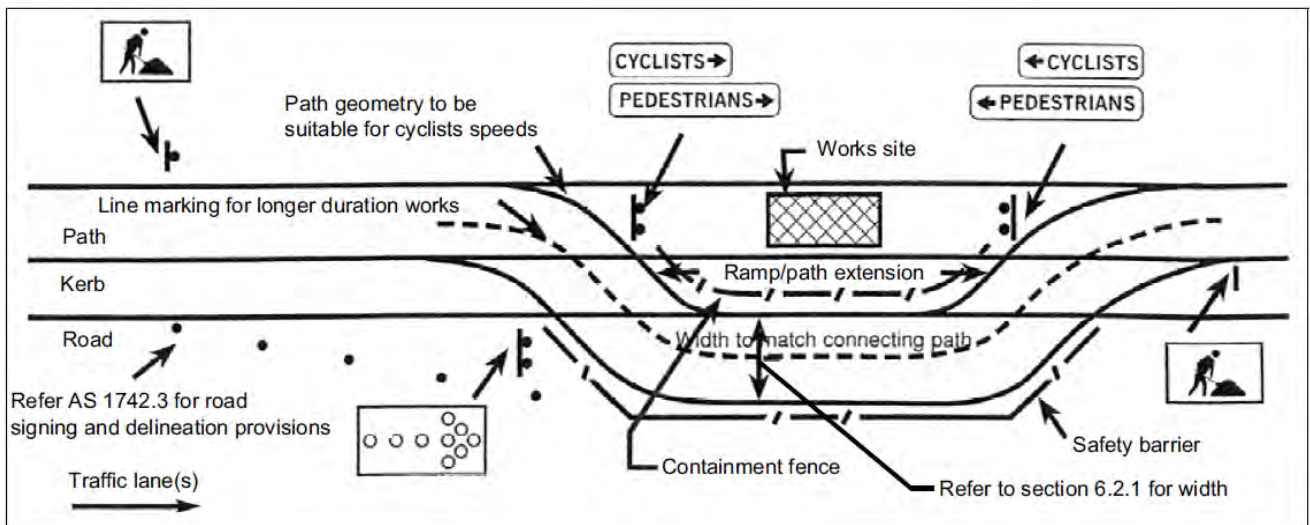

Source: Austroads (2009f) Figure B 4.

Figure E 4: Works on paths – shared use path diversion

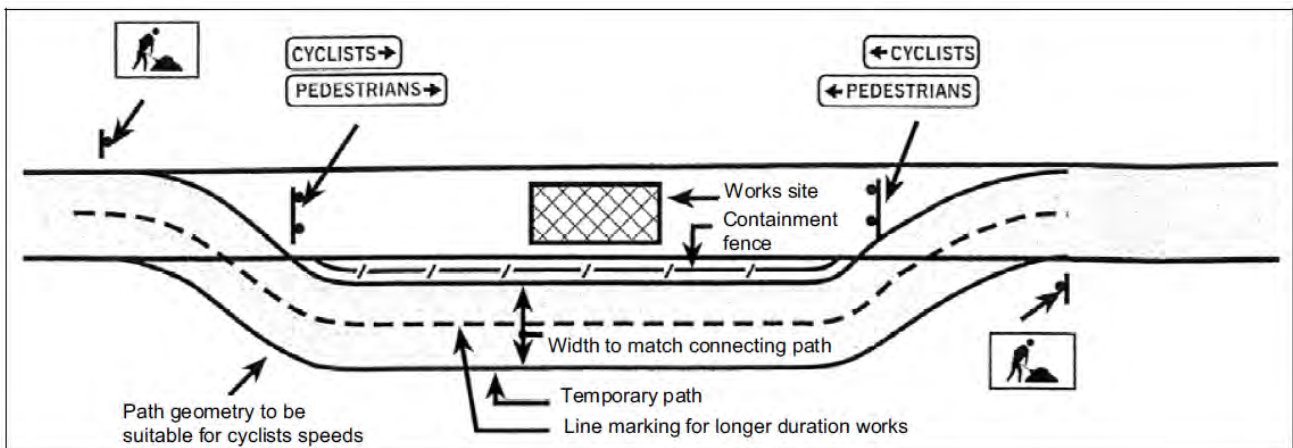

Source: Austroads (2009f) Figure B5.

Provision for cyclists on roads should be made in the following circumstances:

- where bicycle lanes exist
- arterial roads
- collector roads, with an AADT in excess of 3000 vehicles per day
- strategic and other significant bicycle routes.

Safety barriers should be provided where required by AS 1742.3, and are generally appropriate where cyclists or pedestrians are detoured onto roads. Temporary (lower) speed limits may also be appropriate in this circumstance.

With reference to Figure E 2, where adequate provision for cyclists is not possible on a road, access along a path in the area of the roadside verge may be appropriate. Provided adequate separation from the work area can be maintained, it is generally acceptable to initiate and terminate the roadside verge bicycle access within the road lane transition zones either side of the work area.

For paths, reference should be made to Section 3 (in relation to paths located away from road reserves) and to Section 3.5 (separated paths) of GRD 6A (Austroads 2009f), where temporary roadside verge access is required. The controls highlighted in these sections are applicable to temporary paths.

Containment fences should be provided in accordance with the requirements of AS 1742.3, and otherwise as required by GRD 6B (Austroads 2009g). These may be appropriate to separate pedestrians and cyclists where a footpath is to be used for access by cyclists, and where:

- significant pedestrian or bicycle volumes exist
- safety issues may arise due to the unexpected use of a footpath by cyclists.

Temporary paths should be sealed. Whilst dependent on circumstances, such as bicycle volumes, safety and the extent of inconvenience to cyclists, this may be unnecessary where:

- the works are carried out over a short period (e.g. less than two or three weeks duration)
- the temporary path surface is firm, smooth and free of thorns
- the works are carried out during dry weather conditions
- path traffic is minimal.

However, it is very desirable that temporary paths are sealed and delineated where works are carried out over longer periods. Separated paths should be suitably delineated regardless of the period of construction.

Where works on paths are carried out for a period exceeding one day, the works should be made sufficiently visible for night-time path travel, so that path users are able to observe conditions under low ambient light conditions including temporary access paths, and take appropriate action. In addition, as a general principle, lighting on temporary access paths should not be less than the existing level on the original path.

Specific consideration may need to be given to the intersections of paths and roads. The measures taken to protect traffic should be balanced with consideration to all of the potential users and movements at such locations.

Where containment fences are used, to avoid catching the pedals of cyclists the fence should be set back from paths used by cyclists by at least 0.3 m. In the case of flexible mesh fencing particular care is needed to ensure it remains tightly stretched and that it is supported regularly along its length.

Surface tolerances for bicycle riding surfaces are provided in Section 4.2.3 of the GRD 6A (Austroads 2009f).

Where steel road plates are used to cover excavated or damaged pavement surfaces, appropriate steps should be taken to ensure that any steps and grooves are within the permissible tolerances.

E.4 Pavements for Cycling

E.4.1 Pavements for Bicycle Paths

The pavement of paths for cycling must be designed and constructed to a standard that ensures a satisfactory level of service for cyclists throughout the life of the facility.

The maintenance activities discussed previously require the use of a truck and other substantial machinery. If paths are not designed to carry the live loads imparted by this equipment then pavements will suffer structural damage, which will affect use of the facility, and be expensive to repair. All paths should therefore be designed to withstand at least a fully laden small truck.

Most paths should have a hard weatherproof surface. Primarily they can be constructed as a flexible pavement of crushed rock surfaced with asphalt or a bituminous seal, or as a rigid concrete pavement.

It is vital that the sub-grades of both flexible and rigid pavements are compacted to a satisfactory standard and soft areas are treated. It may be necessary in some cases to assess sub-grade conditions along the line of the proposed path.

Individual state and local government authorities will have a preference for particular types of pavement based on experience using local materials that should result in economical pavements. Appropriate pavement design advice should be sought in every instance.

Where paths are located on river banks and likely to become inundated they should be constructed of concrete to provide greater resistance to scour by flood water.

Coloured pavement surfaces are used in some instances (refer to Section 9.4 of this document and GTM 10 [Austroads2009b]).

E.4.2 Bituminous Surface Pavements

Flexible pavements (Figure E 5) have in the past been favoured in some jurisdictions because they are usually cheaper to construct than concrete and have in general provided superior riding qualities.

A recent innovation has been the use of geofabric reinforced bituminous concrete and double spray seal pavements. In addition to a typical flexible pavement design, examples of geofabric reinforced pavements and concrete pavements are shown in Figure E 6. The spray seal version has been used as an economical solution where significant sub-grade movement was expected.

Asphalt mixes should be similar to those used for lightly trafficked streets. The aggregates used for asphalt should not exceed 10 mm nominal size. In the case of sprayed seals, the aggregate size should not exceed 7 mm. Larger aggregates result in an unacceptably rough surface.

Figure E 5: Asphalt path (Croydon Park, NSW)



Source: Austroads (2009f) Figure B 6.

Figure E 6: Typical pavements for paths

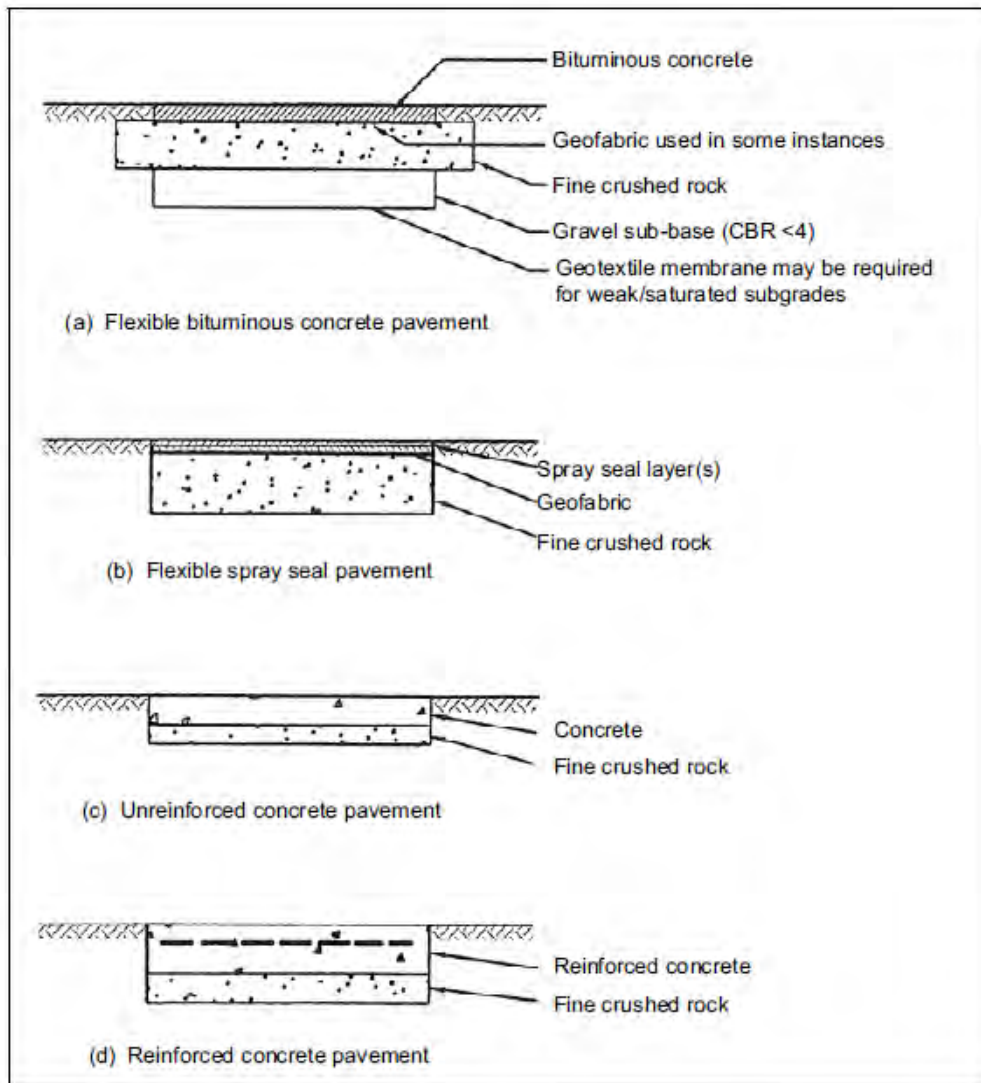

Source: Austroads (2009f) Figure B 7.

For construction purposes road authorities should have detailed requirements and specifications for pavements on bicycle paths and shared paths. An example from New South Wales (Roads and Traffic Authority NSW 2005) is provided in Commentary 12 of the GRD 6A (Austroads 2009f).

E.4.3 Concrete Pavements

The use of concrete paths can be beneficial on the basis of whole-of-life costs, but only where appropriate construction methods are employed. In general, concrete paths have a longer life and are relatively unaffected by:

- inundation and should therefore be preferred for paths close to watercourses
- the deleterious effects of vegetation either at cracks or along the path edges
- low levels of maintenance
- the absence of motor traffic (important to the condition of bituminous pavements)
- poor sub-grade conditions in some instances
- occasional heavy traffic (in the case of reinforced paths).

Concrete paths should be of sufficient strength to resist cracking and differential vertical movement. A skid-resistant surface finish should be provided by transverse brooming of the wet concrete. Similar attention should be given to the smoothness of path sections both at joints and in between.

The development of advanced concrete path construction techniques and products has resulted in significant improvements in rider comfort. It is critical that such techniques (Cement and Concrete Association of Australia 1997) are employed. They include:

- preformed or saw-cut contraction joints. As a consequence bull floating, trowelling and broom finishing can be extended right up to the joints resulting in a considerably improved riding surface. In particular, wet formed contraction joints made using a grooving tool, should be avoided. The sealing of contraction joints may be important to minimise the ingress of dirt and to limit weed growth amongst other benefits
- the use of extended bull floats (up to 4 m wide) to avoid long wave corrugations that affect cyclists travelling at speed
- narrower and fewer joints.

It is sometimes perceived that the contrast between the colour of lines and concrete surfaces is insufficient. Conversely, concrete paths are thought to offer a high standard of delineation for cycling in dark conditions. As for other path surface types, it is important that pavement markings are maintained on concrete paths to a high standard, as illustrated by Figure E 7.

Figure E 7: Concrete path (Normanby Pedestrian and Cycle Link, QLD)



Source: Austroads (2009f) Figure B87, Queensland TMR.

E.4.4 Unsealed Paths

Consideration may be given to the provision of a stabilised unsealed surface as the first stage of development where:

- it is necessary to reduce construction costs
- the path is unlikely to flood to the extent that excessive damage to an unsealed path or excessive maintenance costs will result
- the volume of cyclists initially using the path is expected to be low
- flat gradients exist (e.g. less than 3%)
- costs are to be reduced
- the environmental amenity of an area will be reduced by a sealed path.

The second stage would be the provision of an asphalt, or bituminous surface, or possibly a concrete surface.

Care should be taken in the selection of the (unsealed) surface material to ensure that the riding surface is smooth and well bound, as cyclists will not be attracted to a path that has a poor surface. Well-graded river gravels are most suitable. Materials that result in loose surfacing should not be used under any circumstances. Good drainage is also an important factor in the success of gravel paths.

E.4.5 Timber Surfaces

Gaps between longitudinal planks in timber decks can trap bicycle wheels and cause serious injuries to cyclists. Consideration should therefore be given to remedial treatment of existing timber bridges such as through an asphalt overlay of the outer 1.0 m sections of deck to provide a smooth and safer ride for cyclists. At the very least warning signs should be provided on the approaches to bridges that have longitudinal gaps in the deck.

On new timber bridges the planks should be placed perpendicular to the direction of travel of cyclists. In constructing and maintaining bridges it is important to ensure that the deck joints at abutments and piers provide a smooth and hence safer passage for cyclists.

Drainage should not be a problem when one considers the number of gaps in the decks of timber bridges. However, individual planks have the potential to warp and collect small, localised pools of water. Timber surfaces can be slippery in wet or shady conditions. Where these circumstances are common the application of a non-slip finish is also desirable, regardless of the alignment of planks.

Appendix F Bicycle Safety Audit Checklist

F.1 Introduction

In accordance with the Austroads road safety audit process (GRS 6, Austroads 2009h) it is appropriate that audits of bicycle routes and other facilities are conducted at various stages from planning through to construction, and in relation to existing infrastructure.

Whilst Austroads (2009h) provides considerations for cyclists during various stages of road safety audit, the lists of items in the sections below (sourced from Appendix C of GRD 6A, Austroads 2009f) represent the possible contents of a checklist to assist the identification of relevant safety issues or concerns associated with bicycle facilities on roads and paths. It is unlikely that they include all of the issues that are of relevance or concern to cyclists, particularly given the wide variation in construction and design practice, and the conditions that exist.

It is therefore essential that personnel conducting audits of bicycle facilities are experienced and knowledgeable about the provision of bicycle facilities.

Individual items provided in the lists may be applicable during several audit stages or may only relate to existing infrastructure.

Where existing infrastructure is to be audited, it is important that to some degree the audit is performed on a bicycle and on foot. The type of bicycle used should be representative of the most common type in the region of the audit, but should not have a suspension system or tyres thicker than 32 mm.

Similarly, it is important that safety audit personnel ride at speeds typical of most users – which may be in excess of 25 km/h. Riding at slower speeds may not reveal potential problems such as geometric limitations or pavement surface defects.

Section F.2 is generally applicable to roads, paths and intersections. The requirements that relate mainly to either paths or roads are provided in Section F.9 and Section F.10 respectively.

In so far as roads are concerned, it is assumed that general road safety auditing processes exist, and hence the lists below represent additional considerations for bicycles.

F.2 General Requirements for Roads and Paths

- Are the designated crossing points and routes appropriate and acceptable to meet the required cyclist demand?
- Are the characteristic bicycle use patterns accommodated (i.e. categories of cyclists, volumes, times of travel)?
- Do the proposals account for surrounding bicycle network deficiencies and opportunities?
- Do consistent and suitable provisions exist for the respective categories of cyclists anticipated along the route, or can they be achieved; for instance, is a path required for children and inexperienced cyclists?
- Are grade separated or controlled crossings required?
- Are traffic calming or local area traffic management measures required? (refer to GTM 8, Austroads 2008a).
- Are the requirements of local codes of practice met?

F.3 Alignment and Cross-section

- Does the cross-section of the lane/path facility safely accommodate the anticipated cyclists?
- Are stopping sight distances adequate for all traffic, accounting for paths, roads, driveways, railways etc.?
- Are sight lines applicable to the operation of cyclists obscured by obstacles such as signs, trees, pedestrian fences and parked cars?
- Is the horizontal and vertical alignment suitable? If not, are warning signs installed?
- Are there any sections of riding surface which may cause confusion for users, e.g.:
 - Is alignment of the riding surface clearly defined, particularly at unexpected bends or for dark conditions?
 - Have disused pavement sections been removed or treated?
- Is sufficient route information or guidance provided?
- Does the design avoid or minimise the need for cyclists to slow or stop?
- Do hazardous conditions (e.g. concealed intersecting paths, curves) exist at the bottom of steep gradients?

F.4 Signs, Delineation and Lighting

- Are all necessary pavement markings provided?
- Are there any redundant pavement markings? Have redundant pavement markings been properly removed?
- Are all necessary regulatory, warning and direction signs provided and located appropriately? Are they conspicuous and clear in their intent? Are they at a safe distance/height with respect to the riding surface?
- Are signs in good condition and of an appropriate standard?
- Are there any redundant signs?
- Are fixed objects close to or on the path (trees, fences, holding rails, etc.) treated to ensure visibility at night (e.g. painted white and fitted with reflectors or reflective tape)?
- Are pavement markings clearly visible and effective for all likely conditions (e.g. day, night, rain, fog, rising or setting sun, oncoming headlights, light coloured pavement surface, poor lighting)?
- Are user movements obvious or delineated through intersections?
- Is public lighting of facilities required? Is the lighting design satisfactory, particularly at tunnels, underpasses and areas of high pedestrian activity? Is it operating satisfactorily?
- Are raised pavement markers recessed flushed with the surface or located outside of the paths of travel of cyclists, or outside of bicycle lanes?
- Are thermoplastic markings chamfered?

F.5 Riding Surface

- Is the riding surface suitable for cycling?
- Is the riding surface and edges smooth and free of defects (e.g. grooves, ruts or steps) which could affect the stability of cyclists or cause wheel damage?
- Is the pavement design/construction of a satisfactory standard?
- Can utility service covers, grates, drainage pits etc., be safely negotiated by cyclists?
- Are smooth and flat gutters/channels provided at stormwater drainage pit inlets?

- Is the riding surface free of loose materials (e.g. sand, gravel, broken glass, concrete spills)?
- Is there suitable protection to prevent sand or other debris from depositing on the riding surface?
- Does the riding surface have adequate skid resistance, particularly at curves, intersections, bridge expansion joints and railway crossings?
- Is the riding surface generally free of areas where ponding or flow of water may occur?
- Is special protection required to prevent cyclists from running off the riding surface?

F.6 Vegetation, Maintenance and Construction

- Is suitable access for cycling available during maintenance and construction activities?
- Are all locations free of construction or maintenance equipment?
- In the absence of an appropriate and regular maintenance program:
 - Is there a possibility of the encroachment of grasses into bituminous riding surfaces (e.g. kikuyu) or similar circumstances that could result in poor edge conditions or pavement degradation?
 - Do thorn bearing grasses (e.g. caltrop) exist, or are they likely to be introduced adjacent to the riding surface?
 - Are channels, kerb slots or similar treatments over which cyclists ride, located under deciduous trees etc., or otherwise likely to experience a build-up of debris due to poor drainage conditions?
- Will crack sealing processes or the application of spray seals result in the presence of loose/granular material/sand on the riding surface?
- Does landscaping allow adequate clearances, sight distance etc., and will these be maintained given mature plant growth?
- Could personal security of path users be adversely affected due to the position of bushes and other landscape features?
- Is landscaping required as a wind break?
- Will the positioning of trees and the species used contribute to the degradation of the pavement (e.g. through undermining or moisture variation)?

F.7 Traffic Signals

- Are separate pedestrian and/or bicycle phases provided where necessary?
- Do traffic signals operate correctly? Are signal displays located appropriately for all users?
- Does the design of the signals prevent conflicting motor vehicle movements during crossing phases for pedestrians and cyclists?
- Where a permanent demand for individual phases does not exist, have suitable detection facilities been provided for cyclists? Are these operating satisfactorily?
- Are inductive detector loops provided for bicycle users, are they located appropriately, of a suitable design and do they operate correctly for bicycles in the various stopping positions?
- If push-button actuators have been provided, are they located to allow convenient and legal operation from the normal stopping position (e.g. on the left of riding surface or kerb ramp, behind stop line)? Do they operate correctly?
- Are phasing and phase times acceptable? Are suitable warning signs or guidance for cyclists erected where intersection crossing times are insufficient?

F.8 Physical Objects

- Are fences, safety barrier or other objects located within 1.0 m of the path(s) of cyclists:
 - free of sharp edges, exposed elements or corners so as to minimise the risk of injury to cyclists in the event of the feature/object being struck by a bicycle?
 - designed to minimise the potential for bicycle handle bars or pedals to become caught in the feature should an errant bicycle collide with it?
- If there are any obstructions located adjacent to the paths of cyclists, are they adequately delineated?
- Are clearances to the operating space of cyclists acceptable?

F.9 Paths

This section should be read in conjunction with Section F.2.

F.9.1 General

- Are automatic reticulation systems timed to avoid periods of significant path use? Do sprinklers spray away from the path (rather than across it)?
- Do irrigation hoses need to be placed across path surfaces?
- Are provisions for car parking in the vicinity of the path satisfactory in relation to the operation and safety of path users?
- Are there any potential problems of conflict between the various path users (e.g. pedestrians and cyclists)?
- Is the path subject to flooding? If so, are warning signs provided and located appropriately?

F.9.2 Alignment and Cross-section

- Where a path is located adjacent to a road, is there sufficient separation and/or protection from the carriageway?
- Are adequate overtaking opportunities provided?
- Is the path width, at structures or otherwise, adequate for the likely usage levels of pedestrians and cyclists?
- Is the geometric alignment and gradient satisfactory?
- Is the design speed appropriate?
- Is path crossfall suitable for the anticipated path users?
- Is the crossfall steep enough to adequately drain the path and prevent ponding on the surface, while being flat enough to be comfortable for pedestrians?

F.9.3 Intersections

- If justified, is path priority assigned to path users at road crossings?
- At intersections with busy roads, are appropriate facilities provided, e.g. traffic signals, underpass, overpass or median refuge, to allow path users to safely cross? Are the intersection controls satisfactory?
- Is the location of road/path or path/path intersections satisfactory and obvious with respect to horizontal and vertical alignment?
- Is the presence of intersections obvious to road/path users?
- Is a refuge required at road crossings? Would it adversely affect (e.g. squeeze) cyclists travelling along the road?

- In relation to path entry controls:
 - Are terminal devices required? If so, does the device design meet the requirements of this guide?
 - If central holding rails or bollards exist, is there a legitimate reason why they are needed, and if so is there sufficient pavement width either side?
- Are kerb ramps adequate and suitable for all users (width, slope, flush surface)? Are turning radii adequate?
- Are holding rails provided? Are they positioned so as to not unduly interfere with access for cyclists and other users (consider tandem bicycles, bicycles with trailers etc.)?
- Are the controls associated with path/path intersections satisfactory?

F.10 Roads

This section should be read in conjunction with Section F.2.

F.10.1 General

- Are bicycle lanes required?
- Are bicycle lane widths or the left traffic lane widths adequate to accommodate cyclists?
- Can sufficient space be obtained? Are there any squeeze points for cyclists?
- Does the construction of the lane facility conform to this guide and other relevant standards?
- Are special provisions required along curving roads?
- Are road markings for cyclists suitable and adequate, and do they meet relevant standards?
- On controlled access roads, is a commuter path required within the reservation?
- Are local area traffic management treatments appropriate for bicycles?
- Are drainage pit covers flush with the surface or are there level differences that could be hazardous to cyclists and pedestrians?
- Is the positioning of bicycle pavement symbols potentially hazardous to motorcyclists?
- Are sealed shoulders at least as smooth as traffic lanes?

F.10.2 Intersections

- Are the intersection treatments appropriate?
- Are there any common cyclist movements (legal or otherwise) that differ from typical traffic movements? Are these likely to be anticipated by other traffic? Can these movements be made safely and if not what remedial measures are required?
- Are 'head-start' storage areas required due to conflicting manoeuvres of bicycles and other traffic, or due to high cyclist volumes?
- Are special provisions for cyclists required at roundabouts?
- Are continuity lines marked where appropriate?
- Are grated drainage pits that are potentially hazardous to cyclists and pedestrians located within the road/path intersection or within the turning path of cyclists (i.e. radii in the corners of the intersection)?
- Are grated pits on paths or in close proximity to paths properly designed so that they cannot trap bicycle wheels?

Appendix G Example of Bicycle Safety Audit

G.1 Background

The following example is taken from Section 7.7 of GRS 6 (Austroads 2009h). Shared bicycle/pedestrian paths have been developed beside a major road. A project to convert the major road to full freeway standard has involved modifications to bicycle facilities. The audit took place at the pre-opening stage of the freeway conversion project. Auditing the bicycle facilities was specifically required as part of the audit of the whole project.

G.2 Paths on the North/East Side

- On the south side of Toorak Road there is poor sight distance between the link path from Toorak Road and the main path to the north (under the bridge). The acute angle of connection of these two paths makes movements between them very difficult.

Recommendation 1:

Consider options for improving safety at the junction of the paths, such as provision of signs to warn cyclists/pedestrians of the junction. Consider relocation and realignment of the two paths about 5–10 m further from Toorak Road. (Important).

- At a number of locations there are posts and ends of rails at the edge of the path that are a hazard to any errant cyclist.

Recommendation 2:

Review the design and location of all posts and rails beside the path and shield or modify those in exposed locations. (Important).

- The Keep Left markings at bends along the path include a left-angled arrow above the words. Northbound, just south of Toorak Road, the arrow gives a misleading message about alignment of the path and whether cyclists/pedestrians should use the link path to Toorak Road, which is on the right.

Recommendation 3:

Remove the left pavement arrow from the Keep Left messages, or locate it across the centreline.

- At Toorak Road, the shared path crosses the road at pedestrian signals. At this point the path beside the road is too narrow and is overgrown (Figure G 1).

Recommendation 4:

Widen the path beside Toorak Road.

Figure G 1: The path to pedestrian signals is narrow and overgrown



Source: Austroads (2009h) Figure 7.20.

G.3 Paths on the South/West Side

- The shared path west of Burke Road (adjacent to Carroll Crescent) has a broken surface near the Gardiner railway station.

Recommendation 5:

Repair and maintain surface of the shared path. (Important).

- There is loose gravel on the shared path under the Toorong Road bridge that is a safety hazard for cyclists.

Recommendation 6:

Remove the loose gravel from the shared path. Seal the path. (Important).

- There is no footpath across the railway line where the shared path reaches Toorak Road (Figure G 2).

Recommendation 7:

Provide a footpath across the railway line on the south side of Toorak Road. Link it to the paths on each side. (Important).

Figure G 2: The link path from Toorak Road joins at an acute angle, with restricted sight distance



Source: Austroads (2009h) Figure 7.21.

Appendix H Bicycle Parking Provision Rates

Table H 1 gives an indication of the levels of bicycle parking needed to be provided for various land uses. These bicycle parking provision rates may be used to provide guidance if local standards or data are not available. It should be noted that the application of these types of provision rates needs to be undertaken with caution as local circumstances may often render them inappropriate.

Table H 1: Bicycle parking provision

Land use	Employee/resident parking spaces	Class	Visitor/shopper parking spaces	Class
Amusement parlour	1 or 2	1 or 2	2, plus 1 per 50 m ² gfa	3
Apartment house	1 per 4 habitable rooms	1	1 per 16 habitable rooms	3
Art gallery	1 per 1500 m ² gfa	2	2, plus 1 per 1500 m ² gfa	3
Bank	1 per 200 m ² gfa	2	2	3
Café	1 per 25 m ² gfa	2	2	3
Community centre	1 per 1500 m ² gfa	2	2, plus 1 per 1500 m ² gfa	3
Consulting rooms	1 per 8 practitioners	2	1 per 4 practitioners	3
Drive-in shopping centre	1 per 300 m ² sales floor	1	1 per 500 m ² sales floor	3
Flat	1 per 3 flats	1	1 per 12 flats	3
General hospital	1 per 15 beds	1	1 per 30 beds	3
General industry	1 per 150 m ² gfa	1 or 2	–	3
Health centre	1 per 400 m ² gfa	1 or 2	1 per 200 m ² gfa	3
Hotel	1 per 25 m ² bar floor area 1 per 100 m ² lounge, beer garden	1 1	1 per 25 m ² bar floor area 1 per 100 m ² lounge, beer garden	3
Indoor recreation facility	1 per 4 employees	1 or 2	1 per 200 m ² gfa	3
Library	1 per 500 m ² gfa	1 or 2	4, plus 2 per 200 m ² gfa	3
Light industry	1 per 1000 m ² gfa	1 or 2	–	3
Major sports ground	1 per 1500 spectator places	1	1 per 250 spectator places	3
Market	–	2	1 per 10 stalls	3
Motel	1 per 40 rooms	1	–	3
Museum	1 per 1500 m ² gfa	1	2, plus 1 per 1500 m ² gfa	3
Nursing home	1 per 7 beds	1	1 per 60 beds	3
Office	1 per 200 m ² gfa	1 or 2	1 per 750 m ² over 1000 m ²	3
Place of assembly	–	2	–	3
Public hall	–	1 or 2	–	3
Residential building	1 per 4 lodging rooms	2	1 per 16 lodging rooms	3
Restaurant	1 per 100 m ² public area	1 or 2	2	3
Retail show room	1 per 750 m ² sales floor	1	1 per 1000 m ² sales floor	3
School	1 per 5 pupils over year 4	2	–	3
Service industry	1 per 800 m ² gfa	1	–	3
Service premises	1 per 200 m ² gfa	1	–	3
Shop	1 per 300 m ² gfa	1	1 per 500 m ² over 1000 m ²	3
Swimming pool	–	1 or 2	2 per 20 m ² of pool area	3

Land use	Employee/resident parking spaces	Class	Visitor/shopper parking spaces	Class
Take-away	1 per 100 m ² gfa	1	1 per 50 m ² gfa	3
University/Inst. of Tech	1 per 100p/t students	1 or 2	–	3
	2 per 100f/t students	2		

Notes:

gfa – gross floor area.

Refer to Table 11.2 for Class definitions.

The dash ‘–’ mark in the table indicates that no parking demand information is available, and therefore planners should make their own assessment of the required bicycle parking provisions on an individual project basis.

It is sometimes appropriate to make available 50% of the level of provision recommended in the table at the initial installation stage; however, space should be set aside to allow 100% provision in the event that the full demand for bicycle parking is installed.

Source: Austroads (2008b) Table C2 7 Commentary 2.

Cycling Aspects of Austroads Guides contains information that relates to the planning, design and traffic management of cycling facilities. The information is sourced from Austroads Guides, primarily the Guide to Road Design, the Guide to Traffic Management and the Guide to Road Safety. The publication has been produced to ensure that information is readily available for practitioners who have a specific interest in cycling issues and facilities. Throughout the document practitioners are referred to relevant Austroads Guides for additional information.

Cycling Aspects of Austroads Guides



Austroads

Austroads is the association of Australasian road and transport agencies.

www.austroads.com.au